

# SHORT WAVE & TELEVISION

*The Popular Radio Magazine*



**RADIO PILOTS  
SHIPS INTO PORT**  
SEE PAGE 268

**HUGO  
GERNSBACK**  
EDITOR



**BEST SHORT-WAVE STATION LIST  
HOW TO GET OVERSEAS STATIONS  
NEWEST RADIO EXPERIMENTS  
RADIO QUESTIONS AND ANSWERS**



**25<sup>c</sup>**  
IN U.S. AND  
CANADA

**SEPT.  
1938**



# NEXT MONTH—

BEGINNING with the October Issue, SHORT WAVE & TELEVISION Magazine will change its name to

# RADIO & TELEVISION

This change has been decided upon after mature consideration in order to broaden its field and keep up with the constantly changing art of radio.

All the interesting and instructive features which you have enjoyed for many years will be retained and many new ones added.

The magazine will, hereafter, specialize in Radio Experimentation and Amateur Radio. It will have special appeal to the thousands of young men who aspire to become licensed hams.

The first issue will be a special **AMATEUR RADIO NUMBER**. Practically every outstanding man in the radio field, who was and is still an amateur, will contribute something of interest to every reader.



*Note the names of these outstanding radio men:*

**Dr. Lee de Forest**

Famous Radio Pioneer and Inventor

**E. F. W. Alexanderson**

Consulting Engineer, General Electric Co.

**E. T. Jones**

Manager, Engineering Products  
Advertising and Sales Promotion,  
RCA Manufacturing Co.

**Austin C. Lescarboura**

Radio Pioneer and Public Relation Counsel

**C. W. Horn**

Director of Research and Development,  
National Broadcasting Co.

**R. A. Heising**

Well Known Radio Inventor,  
Bell Telephone Laboratories

**Dr. Frank Conrad**

Assistant Chief Engineer,  
Westinghouse Elec. & Mfg. Co.

**R. H. G. Mathews**

Active in Amateur Radio Since 1909

**Capt. David Talley**

Author of  
"The Army Radio Amateur Network"

**O. B. Hanson**

Vice President and Chief Engineer,  
National Broadcasting Co.

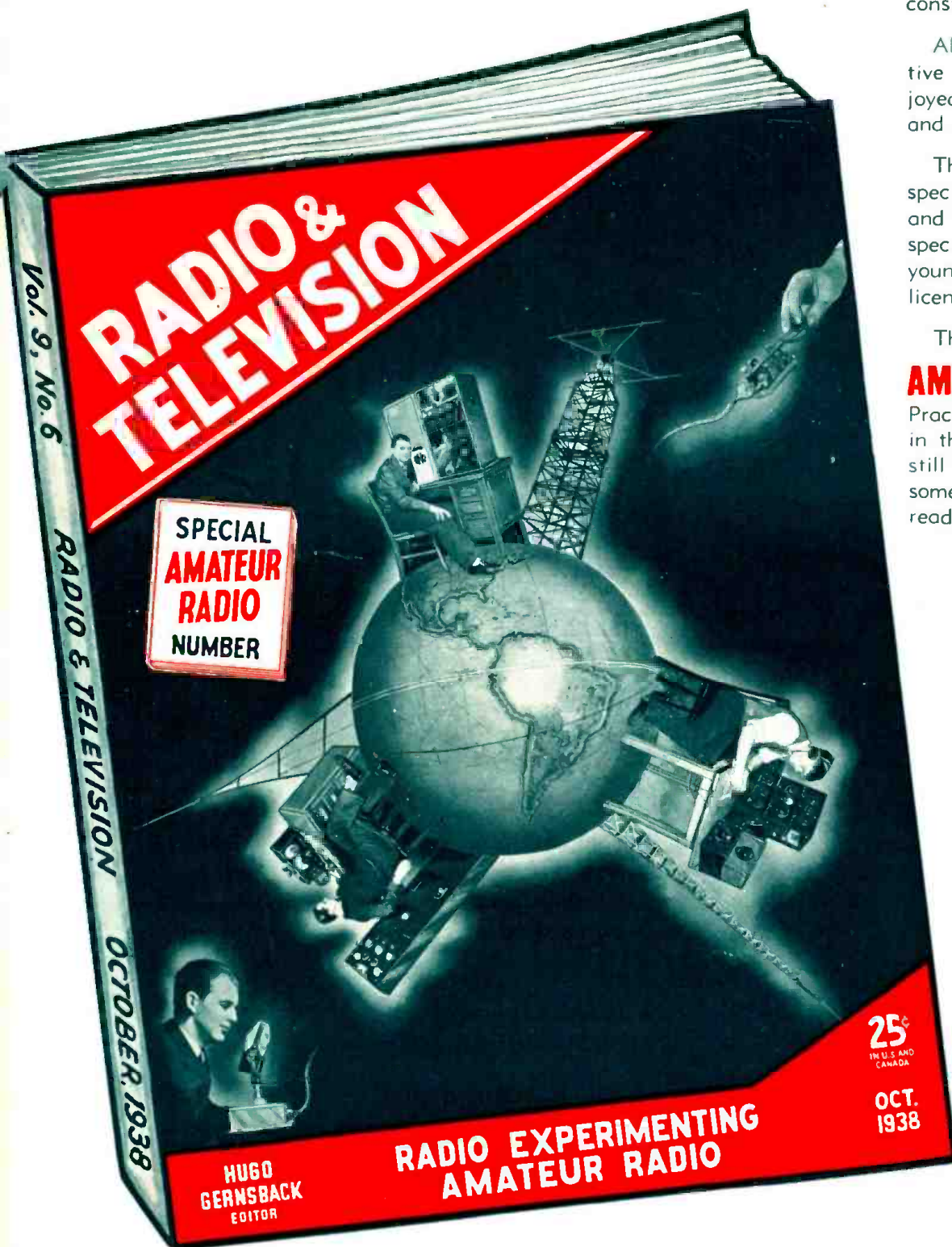

Be sure to order the great October Issue of RADIO & TELEVISION from your newsdealer, as the demand will be unusually heavy due to the special features not heretofore published.

SHORT WAVE & TELEVISION Magazine  
The Publishers



# How a "Tip" got Tom a Good Job

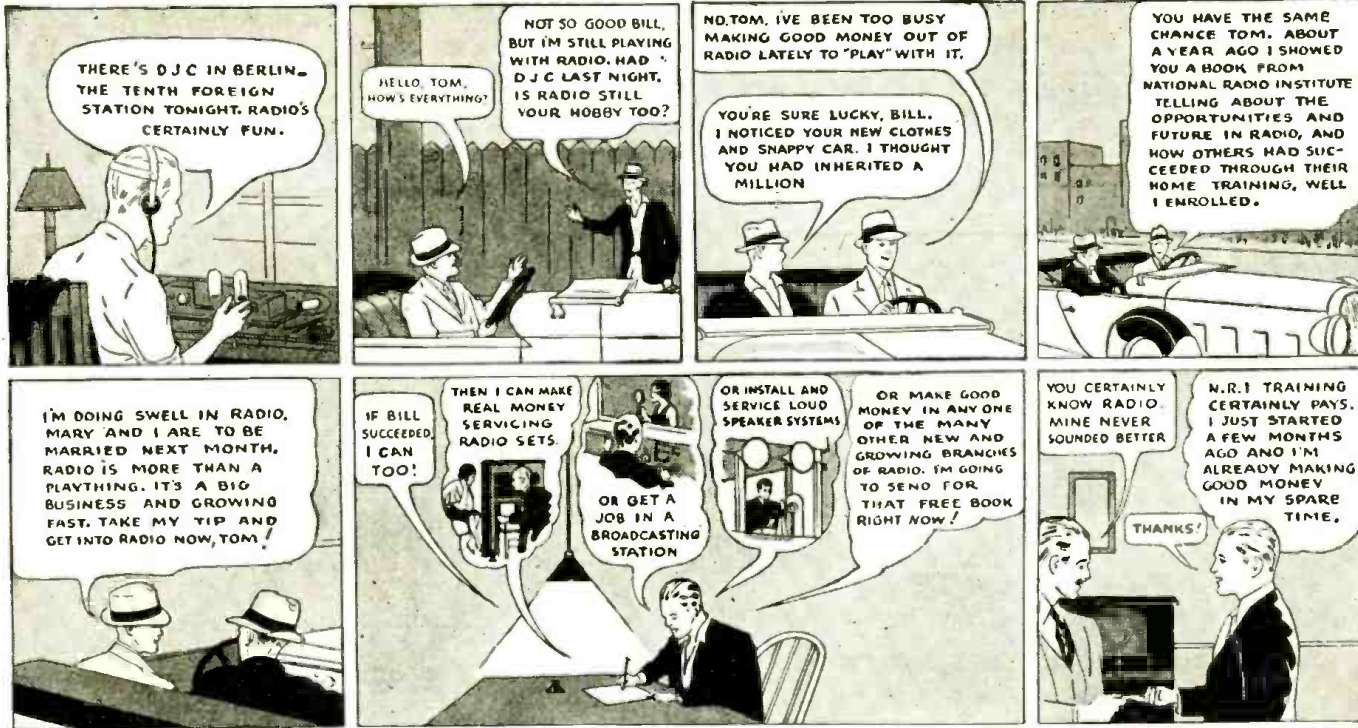

J. E. Smith, President  
National Radio Institute  
Established 1914

**I will train you to start a spare time or full time Radio service business WITHOUT CAPITAL**

**HERE'S PROOF THAT MY TRAINING PAYS**

**\$3,500 a Year In Own Business**  
"After completing the N. R. I. Course I became Radio Editor of the Buffalo Courier. Later I started a Radio Service business of my own, and average over \$3,500 a year"—T. J. TELLAAR, 657 Broadway, Buffalo, N.Y.



**\$10 to \$25 a Week in Spare Time**  
"I am making from \$10 to \$25 a week in spare time while still holding my regular job as a machinist. I owe my success to N. R. I."—WM. F. RUPP, 203 Front St., Conshohocken, Pa.

**GET MY FREE LESSON ON Radio Servicing Tips**

I want to prove that my training is practical, gives money-making information, that it is easy to understand—that it is just what you need to master Radio. My lesson text, "Radio Receiver Troubles—Their Cause and Remedy" covers a long list of Radio receiver troubles in A. C., D. C. battery universal auto. T. R. F., superheterodyne, all-wave and other types of sets. A cross reference system gives you the probable cause and a quick way to locate and remedy these set troubles. A special section is devoted to receiver check-up, alignment, balancing, neutralizing and testing. Get the lesson Free. No obligation. Just mail coupon.

**Many Radio Experts Make \$30, \$50, \$75 a Week**

Do you want to make more money? The world-wide use of Radio sets has made many opportunities for you to have a spare time or full time Radio service business of your own. Four out of every five homes in the United States have Radio sets which regularly require repairs, servicing, new tubes, etc. Many sets are old and will soon be replaced by new models. I will train you to sell, install, repair all types of Radio sets—to start your own Radio repair business and build it up on money made in spare time while learning.

**Get Ready Now for a Business of Your Own and for Jobs Like These**

Broadcasting stations employ engineers, operators, station managers and pay as \$5,000 a year. Fixing Radio sets in spare time pays as much as \$200 to \$500 a year—full time Radio repair jobs pay as much as \$30, \$50, \$75 a week. Many Radio Experts open their own full time or part time Radio sales and repair businesses. Radio manufacturers and jobbers employ testers, inspectors, foremen, engineers, servicemen, paying up to \$6,000 a year. Automobile, police, aviation, commercial Radio, and loud speaker systems offer good opportunities now and for the future. Television promises many good jobs soon. Men I trained at home have good jobs in all these branches of Radio. Read their letters in my 64-page book. Mail the coupon.

**Many Make \$5, \$10, \$15 a Week Extra in Spare Time While Learning**

The day you enroll I start sending you Extra Money Job Sheets. They show you how to do Radio repair jobs—how to cash in quickly. Throughout your training, I send you plans and ideas that have made good spare time money for hundreds of fellows. My Training gives you practical Radio experience while learning.

**I Give You This Professional Servicing Instrument**

Here is the instrument every Radio expert needs and wants—an All-Wave, All-Purpose, Set Servicing Instrument. It contains everything necessary to measure A. C. and D. C. voltages and current; to test tubes, resistance; adjust and align any set, old or new. It satisfies your needs for professional servicing after you graduate—can help you make extra money fixing sets while training.



**Find Out What Radio Offers You—Mail Coupon Now**

Mail the coupon now for my Free Lesson and my book "Rich Rewards in Radio." Both are free to anyone over 16 years old. My book points out Radio's spare time and full time opportunities, and those coming in Television; shows my Training in Radio and Television; tells about my Money Back Agreement; shows you letters from men I trained, telling what they are doing and earning. Find out what Radio offers YOU! MAIL THE COUPON in an envelope, or paste it on a penny postcard—NOW!

J. E. SMITH, President, NATIONAL RADIO INSTITUTE, Dept. 8JB3, Washington, D. C.

**Mail this Now FREE Get 64-page Book**

J. E. SMITH, President, Dept. 8JB3 National Radio Institute, Washington, D. C.

Dear Mr. Smith: I want to take advantage of your offer. Without obligating me, send me your Free Lesson and your book "Rich Rewards in Radio." (Please write plainly.)

NAME ..... AGE .....  
ADDRESS .....  
CITY ..... STATE ..... 14X1



HUGO GERNSBACK, Editor  
 H. WINFIELD SECOR, Manag. Editor  
 M. HARVEY GERNSBACK, Assoc. Editor

## In This Issue

### FEATURES

Ultra Short Wave Broadcasting—Evorett L. Dillard .....	261
Televising the Derby .....	262
American S-W Broadcasting—What's Wrong with It? .....	264
Have You Heard? .....	266
Talking On I-Meter Waves .....	267
Radio Pilots Ships into Port .....	268
Amateur Antenna Theory and Application—Ralph L. Tedesco .....	269
Short Wave FOTO NEWS .....	270
W8XWJ Broadcasts Daily on 7.3 Meters .....	271

### S-W STATIONS—HOW TO FIND THEM

Short Wave League—On the Ham Bands .....	274
Let's Listen In with Joe Miller .....	276
World Short Wave Stations .....	278

### TELEVISION

Televising the Derby .....	262
Television News Photos .....	270

### CONSTRUCTOR

Aerial Mast Made From a Ladder .....	287
Suppressor Grid Modulated Transmitter—C.W. and Phone—M. N. Beitman .....	291
"5 in 4" All-Wave T. R. F. Receiver—Harry D. Hooton, W8KPX .....	292
A Beat-Frequency Oscillator—Herman Yellin, W2AJL .....	294
Portable 30-Watt Transmitter—J. E. Striker, W6MOV-W6OPG .....	296

### MISCELLANEOUS

Can YOU Answer These Radio Questions? .....	268
What Do You Think? .....	272
Short Wave League—On the Ham Bands .....	274
Third Silver Trophy Award for Best "Ham" Station Photo .....	279
DX Receiving Aerials .....	281
Radio "Kinks"—Monthly Prizes .....	283
New Experiments with Radio Apparatus .....	285
A Loop Aerial for Short Waves .....	287
Question Box .....	288
New Short-Wave Apparatus .....	290
Book Review .....	299

Cover composition by H. Gernsback and Thomas D. Pentz. Photos courtesy Western Electric Company.

SHORT WAVE & TELEVISION—Published monthly on the tenth of the month. Entered as second-class matter Feb. 15, 1938, at the post office at Springfield, Mass., under the act of March 3, 1879. Trademarks and copyrights by permission of H. Gernsback. Text and illustrations are copyright and may not be reproduced without permission. Subscription price \$2.50 a year in the United States and possessions and Canada, \$3.00 in foreign countries. Make all subscription checks payable to Popular Book Corporation.

Published by Popular Book Corporation. Publication Office—29 Worthington St., Springfield, Mass. Editorial and Executive Offices—99 Hudson St., New York, N.Y. HUGO GERNSBACK, President; H. W. SECOR, Vice-President; EMIL GROSSMAN, Director of Advertising. European Agents: Atlas Publishing and Distributing Co., Ltd., 18 Bride Lane, Fleet St., London, England; Brentano's—London and Paris. Australian Agents: McGill's Agency, 179 Elizabeth St., Melbourne.

Copyright 1938 by H. Gernsback

## In the Oct. Issue

- A Day in the Life of a Busy Amateur, E. E. C. England, VE3QL.
- How to Learn the Radio Code Easily, Everett L. Dillard and Frank Collins.
- Learning Foreign Languages by Short Waves, Hon. Michael Norton, B.A.
- A Communications Receiver of Improved Type—for Hams and Fans, Howard G. McEntee, W2FHP.
- New Radio Amateur Course, Martin Clifford.
- A Good 5-Meter Receiver, Herman Yellin, W2AJL.
- A Modulator for the 35-Watt Transmitter, Harry D. Hooton, W8KPX.



Here is a photo of the modulator to be described by Harry D. Hooton, W8KPX, in the October number. It is especially designed for use with low-powered transmitters.



### Certified Circuits

When you see this seal on a set it is a guarantee that it has been tested and certified in our laboratories, as well as privately in different parts of the country. Only constructional—experimental sets are certified.

You need not hesitate to spend money on parts because the set and circuit are bona fide.

This is the only magazine that renders such a service.



# TRAIN FOR RADIO IN 12 WEEKS

## BY MY QUICK, EASY "LEARN BY DOING" METHOD



Prepare today to enter a real money-making field by my quick, easy way to learn Radio. Here in my school you are trained in 12 weeks for your start for a better job and a real future. You do actual work on a great outlay of Radio equipment. The remarkable "Learn-By-Doing" methods used in the great Coyne Shops train you in **Radio, Television** and sound equipment servicing. Not by books . . . Not by Correspondence . . . But all under the individual guidance of skilled instructors, and only on similar kind of work you will meet out on a real job. My methods make it **easy to learn**—First you are **told** how to do a thing—then you are **shown** how to do it—then you **do the work yourself**. WHERE ELSE CAN YOU FIND SO QUICK AND EASY A WAY TO GET PRACTICAL TRAINING IN THIS GIANT INDUSTRY?

# I'LL FINANCE YOUR TRAINING

**DON'T LET LACK OF MONEY** keep you from sending in the Coupon TODAY. Learn how you can get training first and take more than a year to pay for it after graduation. Make your first payment 60 days after your regular 12 weeks' training period ends. Then take over a year to pay the balance of your tuition in easy monthly payments. Hundreds of ambitious fellows have used this method to get Coyne Training. **FILL IN THE COUPON AND MAIL IT TODAY.** It will bring you the details of this amazingly quick and easy way to get your start towards a good pay job.



*H. C. Lewis*

### Radio—Television—Sound Equipment

Your training at Coyne is in wonderful, modern daylight shops on the finest kind of **RADIO, TELEVISION and SOUND EQUIPMENT.** Television is sure to come as a commercial industry, whether this year or next. Talking Picture and Public Address Systems offer opportunities for the trained man. Everything possible has been done to make your stay at Coyne happy and healthful as well as profitable.

### Electric Refrigeration Training Included at No Extra Cost

This combination Training (Radio and Refrigeration) can be of great value to you. Whether you go into business for yourself or get a job working for a Radio Sales and Service organization, the fact that you are trained in servicing Electric Refrigerators should be profitable to you. Many Radio Manufacturers also make Electric Refrigerators and men with this combination training are much more valuable to these employers. You can **NOW** get this training without extra cost.

### No Advanced Education or Previous Experience Needed

If you can read and write simple English and are ambitious you can be trained the Coyne way—by actual experience on a wide variety of up-to-date Superheterodyne sets, oscillators, analyzers, and test instruments. You learn how to operate television receiving and transmitting equipment and how to install, test and service public address systems and sound picture equipment. Coyne training also helps prepare you to qualify for a government license examination as Amateur Broadcast or Telegraph Radio Operator and to know Code and Department of Commerce rules. Send coupon for all details.

### Part Time Work While Learning Employment Service after Graduation

If you need part time work to help pay living expenses while training, my Employment Department will help you get it. They will also give you Lifetime Employment Service after you graduate.

### Mail Coupon Today I'll Send You All the Facts

Get the new "Coyne Opportunity Catalog," giving all facts about Coyne Training. Photographs of Shops showing students at work on modern radio equipment under the personal supervision of Coyne Expert Instructors. Also details of my Part Time Employment Offer, Pay After Graduation Plan and Graduate Employment Service. Yours without cost. Simply Mail the Coupon.



H. C. LEWIS, President,  
Radio Division, Coyne Electrical School,  
500 S. Paulina St., Dept. D8-2K, Chicago, Ill.

Send me your big FREE Book about Coyne Training and give me all details regarding your "Part Time Employment Offer" and "Pay After Graduation Plan" of easy, monthly payments.

NAME.....AGE.....  
ADDRESS.....  
CITY.....STATE.....

H. C. LEWIS, President RADIO DIVISION Founded 1899  
**COYNE ELECTRICAL SCHOOL**  
500 S. Paulina St., Dept. D8-2K, Chicago, Ill.

**You can't lose! A money-back guarantee protects you!**

**THE RADIO AMATEUR COURSE REPRESENTS THE GREATEST BOOK VALUE EVER OFFERED TO RADIO "FANS" FOR 50c**

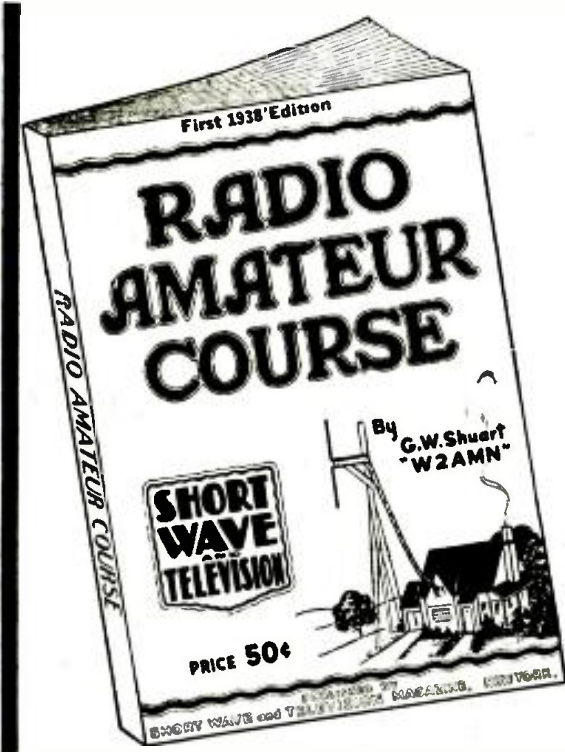

**T**O convince you that there isn't a better book buy today the publishers of the **RADIO AMATEUR COURSE** make the sensational offer of a money-back guarantee on such a low-priced book. Stop in at any of the many dealers listed below and examine this volume. See for yourself if the **RADIO AMATEUR COURSE** is just the book you've always wanted.

**148 PAGES . . . 6 1/4 x 9 1/2 INCHES  
OVER 150 DIAGRAMS AND PHOTOGRAPHS**

Printed on the finest quality paper—well illustrated—attractive 4-color cover—complete with radio information you must have. It contains a step-by-step program for obtaining a short-wave radio education.

*Written by George W. Shuart, W2AMN, foremost short-wave authority*

**ON SALE AT THE FOLLOWING DEALERS**

- ARIZONA**  
Sam's Cigar Store,  
127 N. First Ave., Phoenix.
- CALIFORNIA**  
Scott Wholesale Radio Co.,  
344 E. Fourth Street, Long Beach.  
Offenbach Electric Co., Ltd.,  
1452 Market Street, San Francisco.  
Zack Radio Supply Co.,  
1426 Market Street, San Francisco.
- COLORADO**  
Auto Equipment Co.,  
14th at Lawrence, Denver.
- CONNECTICUT**  
Radio Inspection Service Co.,  
227 Asylum Street, Hartford.  
Stern Wholesale Parts, Inc.,  
210 Chapel St., Hartford.
- GEORGIA**  
Wholesale Radio Service Co., Inc.,  
430 W. Peachtree St., N. W., Atlanta.
- ILLINOIS**  
Allied Radio Corporation,  
833 West Jackson Blvd., Chicago.  
Newark Electric Company,  
226 W. Madison Street, Chicago.  
Wholesale Radio Service Co., Inc.,  
901 W. Jackson Blvd., Chicago.
- INDIANA**  
Van Sickle Radio, Inc.,  
34 West Ohio Street, Indianapolis.
- MASSACHUSETTS**  
Greater Boston Distributors,  
40 Waltham St., Boston.  
H. Jappe Co., 46 Cornhill, Boston.  
Wholesale Radio Service Co., Inc.,  
110 Federal Street, Boston.  
Springfield Radio Co.,  
397 Dwight Street, Springfield.  
H. Jappe Co.,  
97 Mechanic Street, Worcester.
- MICHIGAN**  
Rissl Brothers, Inc.,  
5027 Hamilton Ave., Detroit.

- MISSOURI**  
Modern Radio Company,  
409 No. Third Street, Hannibal.  
Burstein-Angleber Co.,  
1012-14 McGee Street, Kansas City.  
Van Sickle Radio Co.,  
1113 Pine Street, St. Louis.
- NEBRASKA**  
Radio Accessories Company,  
2566 Farnam Street, Omaha.
- NEW HAMPSHIRE**  
Radio Service Laboratory,  
1187 Elm Street, Manchester.
- NEW JERSEY**  
Arco Radio Co.,  
227 Central Avenue, Newark.  
Wholesale Radio Service Co., Inc.,  
219 Central Avenue, Newark.
- NEW YORK**  
Wholesale Radio Service Co., Inc.,  
542 E. Fortham Rd., Bronx.  
Wholesale Radio Service Co., Inc.,  
90-08 168th Street, Jamaica, L. I.  
Blau, The Radio Man, Inc.,  
64 Dey Street, New York City.  
Eagle Radio Co.,  
84 Cortlandt Street, New York City.  
Federated Purchaser, Inc.,  
25 Park Place, New York City.  
Harrison Radio Co.,  
12 West Broadway, New York City.  
Sun Radio Co.,  
212 Fulton Street, New York City.  
Terminal Radio Corp.,  
80 Cortlandt Street, New York City.  
Thor Radio Corp.,  
65 Cortlandt St., New York City.  
Try-Mo Radio Co., Inc.,  
85 Cortlandt Street, New York City.  
Wholesale Radio Service Co., Inc.,  
100 Sixth Avenue, New York City.  
Radio Parts & Equipment Co.,  
244 Clinton Avenue No., Rochester.  
M. Schwartz & Son,  
710-712 Broadway, Schenectady.

- OHIO**  
News Exchange,  
51 So. Main Street, Akron.  
Canton Radio & Supply Co.,  
1140 Tuscarawas Street, W., Canton.  
United Radio, Inc.,  
1103 Vine Street, Cincinnati.  
The Hughes-Peters Electric Corp.,  
178-180 N. Third Street, Columbus.  
Standard Radio Parts Co.,  
135 East Second Street, Dayton.
- OREGON**  
Portland Radio Supply Co.,  
1300 W. Burnside Street, Portland.
- PENNSYLVANIA**  
Radio Distributing Co.,  
1123-26 Market Street, Harrisburg.  
M. & H. Sporting Goods Co.,  
512 Market Street, Philadelphia.  
Cameraadio Co.,  
963 Liberty Ave., Pittsburgh.
- RHODE ISLAND**  
W. H. Edwards Co.,  
32 Broadway, Providence, R. I.
- UTAH**  
O'Loughlin's Wholesale Radio Supply,  
315 South Main Street, Salt Lake City.  
Radio Supply, Inc.,  
46 Exchange Place, Salt Lake City.
- WASHINGTON**  
Spokane Radio Co., Inc.,  
611 First Avenue, Spokane.
- WISCONSIN**  
Radio Parts Co., Inc.,  
536-538 W. State Street, Milwaukee.

- TEXAS**  
Amarillo Electric Co.,  
111 East 8th Avenue, Amarillo.
- AUSTRALIA**  
McGill's Agency,  
183-184 Elizabeth Street, Melbourne.
- CANADA**  
The T. Eaton Co., Ltd.,  
Winnipeg, Manitoba.  
Canadian Electrical Supply Co., Limited,  
285 Craig Street W., Montreal, Que.  
Metropolitan News Agency,  
1248 Peel Street, Montreal, Que.
- CUBA**  
The Diamond News Co.,  
Palacio Asturiano, Por San Jose,  
Habana.
- ENGLAND**  
Gorringe's American News Agency,  
9a, Green Street, Leicester Square,  
London, W.C.2.
- HOLLAND**  
Radio Peeters, Van Wovstraat, Amsterdam, Z.
- INDIA**  
Empire Book Mart,  
Box 631, Bombay.
- MEXICO**  
American Book Store, S. A.,  
Avenida Madero 25, Mexico City.  
Central De Publicaciones,  
Avenida Juarez, 4, Apartado 2430,  
Mexico, D. F.
- NEW ZEALAND**  
Te Aro Book Depot, Ltd.,  
64 Courtenay Place, Wellington.
- SOUTH AFRICA**  
Technical Book Co.,  
147 Longmarket Street, Cape Town.

Be sure to see all future copies of **SHORT WAVE AND TELEVISION** for additional listings of dealers handling the **RADIO AMATEUR COURSE**.

**SHORT WAVE AND TELEVISION**  
99 HUDSON ST., NEW YORK CITY

*If this book is not at your dealer's, send your order directly to us. We will credit your dealer with the sale of this book. To order your copy of RADIO AMATEUR COURSE, fill in coupon below and mail.*

**SHORT WAVE AND TELEVISION, 99 HUDSON STREET NEW YORK, N. Y.**  
Gentlemen: I enclose herewith my remittance of Fifty Cents (50c) for which please send me **POSTPAID**, my copy of the **RADIO AMATEUR COURSE**. (Remit by check or money order; register letter if you send cash or unused U.S. Postage Stamps.)

Name .....

Address .....

City ..... State .....

8WT-938



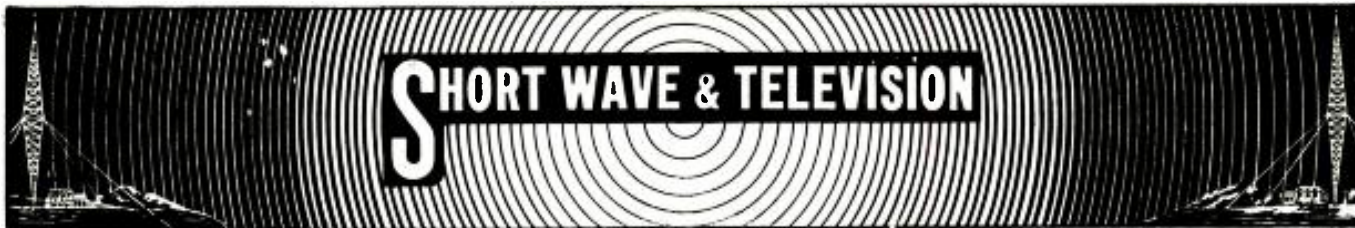

HUGO GERNSBACK, EDITOR

H. WINFIELD SECOR, MANAGING EDITOR

# The HIGH FREQUENCY *Broadcasting Station—* 10 Meters and Down!

Everett L. Dillard

Does the Apex Station solve radio broadcasting's needs  
for local station expansion?



Everett L. Dillard, chief engineer, Apex Broadcasting Station, W9XA, Commercial Radio Equipment Co., Kansas City, Missouri. Mr. Dillard is well known for his researches in the high frequency field.

● SEVERAL years ago the useful range of radio frequencies was considered to be those frequencies below 30 megacycles (10 meters); in other words, wavelengths *higher* than ten meters. All frequencies above this limit were considered as being an unknown quantity and of doubtful commercial worth.

With the continued and necessary expansion for different classes of radio services depending more or less upon local coverage, such as police radio, relay broadcasting, etc., licenses were granted these services by our Government for experimental stations to be operated on frequencies above 30 megacycles, in the hope that what had heretofore been considered as more or less worthless radio territory would prove adaptable for this type of service. The increasing number of these stations during the past three years and their reported successes in providing good local coverage, as well as the simultaneous, non-commercial but nevertheless closely allied work of the radio amateur in two-way communication in the 5-meter band in metropolitan areas, proved definitely that *frequencies above 30 megacycles could be used to provide satisfactory local radio coverage in even thickly populated areas.*

Naturally the radio broadcasting industry, confronted with an already overcrowded condition on standard broadcast channels, looked with hungry eyes to this ultra-high frequency band as a possible solution to its needs for more and more broadcast stations, especially those which are classified in the "local" station category.

However, good broadcasting service demands more in the matter of signal-to-noise ratio than simple reliable communication service. In the case of communication between police headquarters and car cruiser it is only necessary to have sufficient signal strength at both ends of the circuit to afford intelligible communication. Broadcasting, on the other hand, demands far more than mere intelligibility. Reception of music and voice cannot be marred, even by occasional static or interference, if the entertainment value of the program is to be maintained. This means that music and voice must override all radio "noises," whether man-made or otherwise.

Of the two sources of interference, that originated by *man-made* electrical devices is particularly vicious at these frequencies. Fortunately, nature has not produced, successfully, static that is very potent on the ultra-highs; but auto-ignition and similar disturbances are a problem of considerable magnitude that must be whipped. Can a sufficiently strong signal be developed in metropolitan areas to provide an acceptable high-fidelity broadcast quality reception? That is the problem. The solution lies in compulsory noise suppression at the originating source, the use of high transmitter power, strategic station location, and the use of directive antenna systems. No doubt a combination of all four of the above will be necessary on the *ultra-highs* to produce

programs of maximum entertainment value and signals free from interference.

The Federal Communications Commission was quick to see the possibilities of a local broadcast service on the ultra-high frequencies, and established a new type of experimental station known as the High Frequency Broadcast Station—sometimes called an *Apex Broadcasting Station*. Accordingly, the Commission has granted to a number of responsible applicants licenses of an experimental nature to test the merits of local broadcasting on the ultra-high frequencies. Furthermore, in its recent allocation of frequencies from 30 to 300 megacycles, the Commission has generously set aside a number of frequencies on which to operate these experimental stations. No one knows just what the operation of these stations will prove; but if their operation is a success, and it is found that good broadcasting service can be delivered over a limited area, the Broadcasting Industry will no longer need to worry about where to put new "local" stations; for the Commission has wisely set aside an ample number of frequencies to accommodate any necessary expansion for many years to come.

It also appears that the Apex broadcasting frequency bands will provide radio broadcasting channels for those many smaller communities now deprived of radio service, which local service they lack only because of congestion in the regular broadcast band. In all other respects these communities may have the necessary population.  
*(Continued on page 312)*

*Twenty-first of a Series of  
"Guest" Editorials*

# TELEVISION

How the first television broadcast of the famous

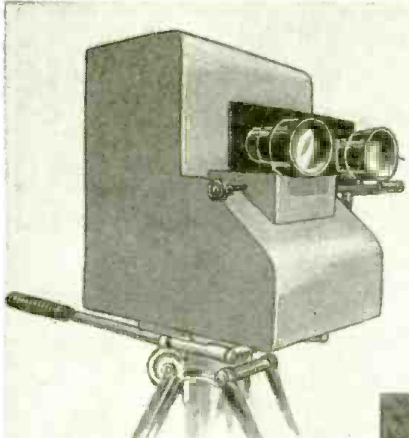

CAMERAS

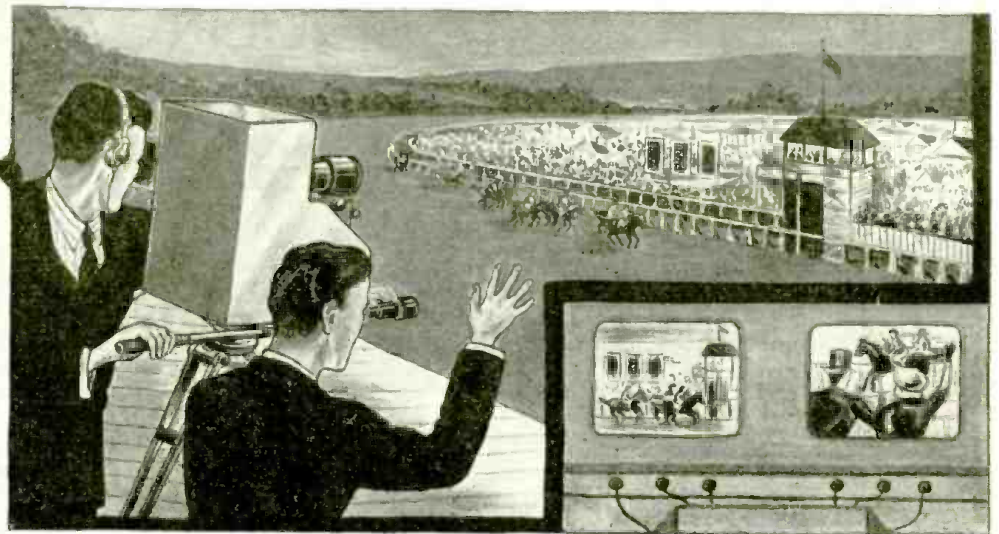
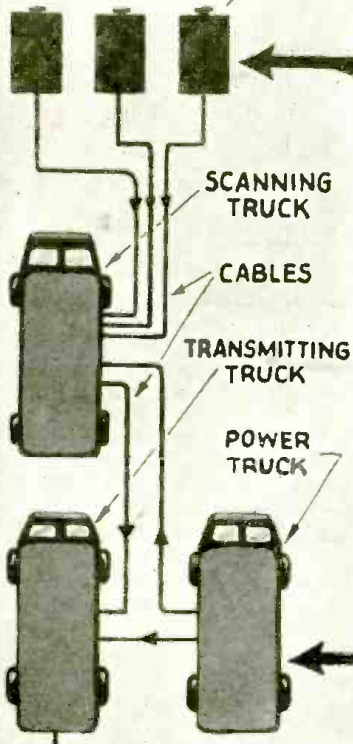

Three television cameras or iconoscopes were set up beside the race course at Epsom—site of the famous English Derby. These cameras were placed at different vantage points for picking up the images. The mobile television transmitter unit consists of three large trucks. The scanning truck contains equipment for mixing the outputs of the cameras and amplifying the combined signals. It also contains monitoring screens for each of the television cameras. The operator sits in front of the screens where he can see everything being picked up by each of the cameras. On one of the screens appears exactly what is being sent out over the air to television viewers. The other two screens show what the other two cameras are picking up, and by use of a set of fader controls, the operator can fade in either one of these other cameras.

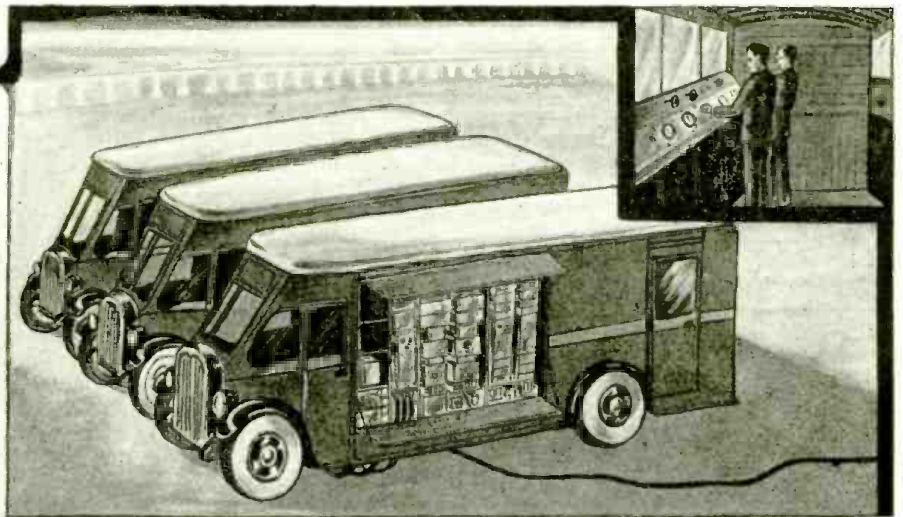

The second truck contains an ultra short wave transmitter which is fed the picture impulses from the scanning truck. A special directional transmitting aerial, used in connection with the transmitting truck, is mounted on a pole on the roof of one of the grandstands and connected by feeder lines to the transmitter. The third truck contains power supply equipment.

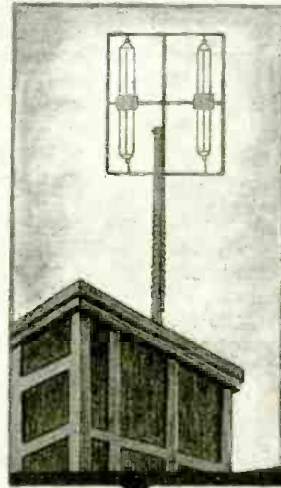

EPSOM AERIAL

RADIO TRANSMISSION





# the DERBY

English Derby at Epsom was arranged by the B. B. C.

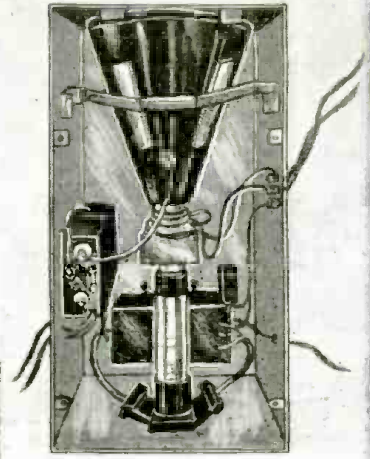

HOME RECEIVER



RADIO TRANSMISSION

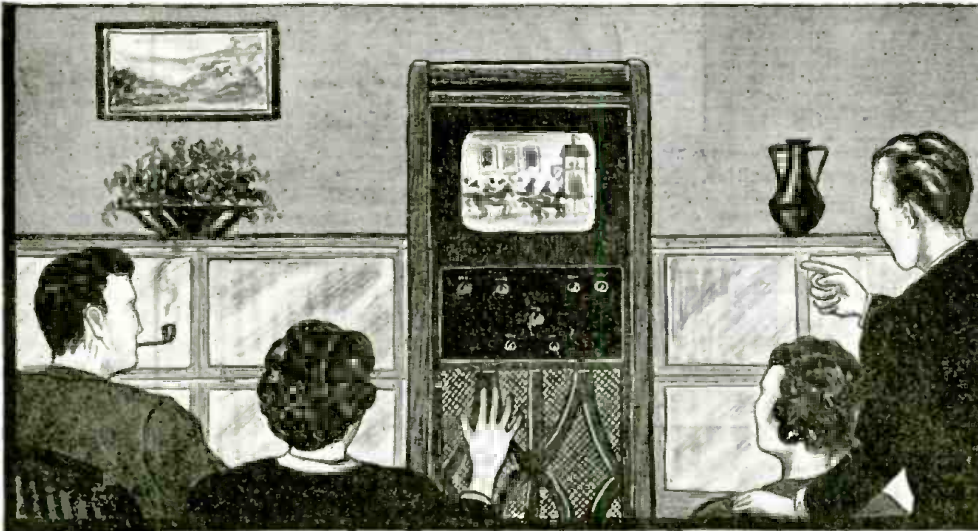

The picture impulses are amplified and converted into radio waves once more at Alexandra Palace and broadcast from the high-powered television transmitter on a wave length of about seven meters, to be picked up and reproduced on the television receivers in the homes of Britishers living within an area of 50 miles of London.

While the range of the television station broadcasting the images of the Derby was nominally expressed as fifty miles, the signals were actually picked up much farther away. As tests in this country have shown, the images are often picked up several hundred miles away and in fact the B.B.C. images were once picked up in South Africa, a distance of six thousand miles! It is safe to say that the Derby images were undoubtedly seen by televisioners equipped with experimental receivers located 150 to 300 miles from the transmitting station.

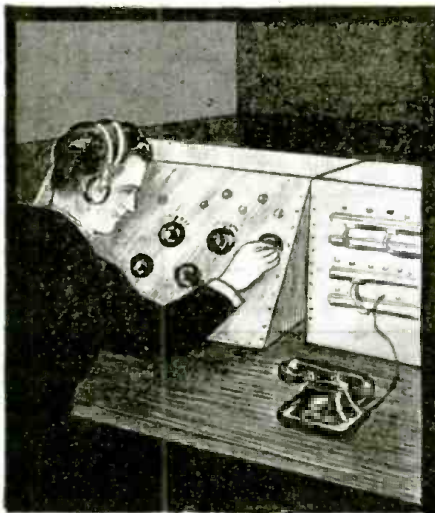

The signals sent out from the mobile transmitter on ultra short waves are picked up at a remote point by the special receiving equipment shown above. From here the signal impulses go by special telephone cables to the main television transmitting plant at Alexandra Palace in London.

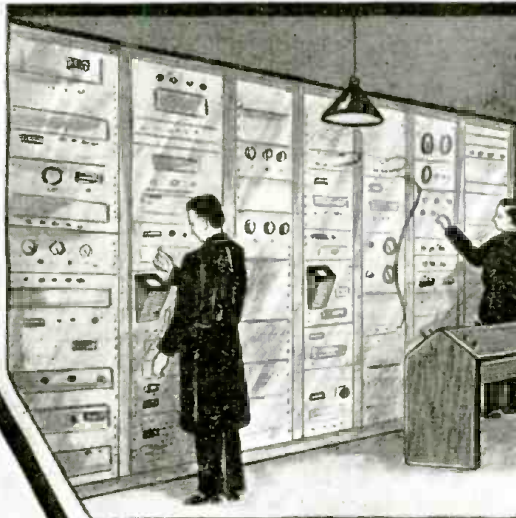

A.P. AERIAL

ALEXANDRA PALACE

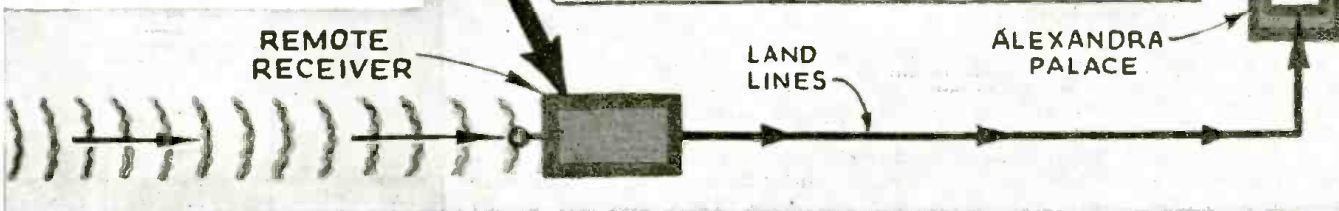

REMOTE RECEIVER

LAND LINES





Professor Harlow Shapley, Dr. A. E. Kennelly, of Harvard University and Dr. Loring B. Andrews, chairman of WIXAL program committee, at the WIXAL transmitter.

# American Broad- *What's Wrong*

● **FEELING** that a turn-about is fair play, the United States broadcasters are now sending out elaborate short-wave programs in foreign languages for the benefit of *foreign* listeners, in an effort to keep up with the multi-lingual short-wave broadcasts sent out by the principal short-wave stations of Europe and Asia.

From dawn to midnight, specially prepared programs for the entertainment and education of foreign listeners are shot to the four corners of the world from powerful transmitting plants in different parts of the U. S. From Bound Brook, New Jersey, the National Broadcasting Company sprays programs at Europe and South America in six languages. In New York the Columbia Broadcasting System's short-wave outlet "sounds off" in three languages. At Boston the educational station of the World Wide Broadcasting Foundation sends out a variety of programs from Harvard University classrooms and its own studios in languages ranging from Greek to Scandinavian. And from Schenectady, N. Y., and Pittsburgh, Pa., still other foreign language broadcasts wend their way to distant lands.

#### Outstanding Educational Program Station

One of the most unusual stations, as far as programs go, is WIXAL, Boston station of the World-Wide Broadcasting Foundation. This is a non-commercial station whose primary purpose is the dissemination of educational and good-will programs. This station was founded by Walter S. Lemmon, engineer and International Business Machines Corporation executive. Mr. Lemmon started the station at his own expense, but subsequently, the Rockefeller Foundation became a substantial backer of the station. Private individuals, including thousands of listeners, have also contributed funds for the station's work. An elaborate program of educational work has been undertaken by the station. Printed literature tying in with broadcast material is sent to interested listeners so that they may get greater benefits from programs. Programs are transmitted in Spanish, French, Greek and Portuguese for the benefit of European and South American listeners. In addition, news broadcasts in several other languages are part of the

daily fare from WIXAL. Several New England universities cooperate in the preparation of the programs of the station. The type of material sent out is of a much higher caliber than that which the average



consist of news bulletins and rebroadcasts of American network programs with foreign language announcements replacing the English announcements. South American audiences receive their daily ration of programs in Spanish and Portuguese during our evening hours which, of course, correspond with South America's evening hours. A similar pattern is followed with these programs. News bulletins in Spanish and Portuguese are interspersed with commercial network programs, with foreign language announcements. In addition, special feature programs, designed only for foreign listeners, are broadcast. Advance program sheets, printed in three languages, are sent to the foreign press with complete details of all programs to be broadcast.

The General Electric stations, W2XAF-W2XAD, at Schenectady, have a similar

Left—Miss Carmen Castelo, Spanish-speaking theatrical columnist, broadcasts over W2XE, New York, for South America.

Below—Walter Lemmon, founder and president of WIXAL at Boston.

commercial broadcast station would send out. Frequently, classroom lectures are broadcast from New England universities. Phonograph records of these lectures are made so that they may be rebroadcast at an hour which will insure reception in distant countries at a convenient listening time. Another activity of this station in the field of international good-will is the supplying of recorded programs to Latin American broadcasting stations so that they may be broadcast to local audiences throughout Latin America.

#### NBC's Foreign Language Barrage

The National Broadcasting Company's station, W3XAL, at Bound Brook, N. J., caters to European listeners with one hour daily programs in Italian, German and French, and with five hours of program in English for the benefit of English-speaking Europeans. These programs usually





# Short Wave casting— *With It?*



Laura Suarez, Brazilian soprano who appears on programs for South American listeners over W3XAL, Bound Brook, N. J.

Three Spanish-speaking artists participating in a special program from New York, for Argentina's Independence Day, broadcasting over W2XE.



service for Europe and South America. However, when broadcasting to South America, two different programs are sent out simultaneously — one in the Portuguese language and one in the Spanish language. Portuguese is the principal language of Brazil, while most of the people in the rest of South America speak Spanish.

### Special Staffs for S-W Programs

Both the National Broadcasting Company and the General Electric Company maintain separate program staffs for *short-wave* activities.

The Columbia Broadcasting System operates a short-wave station in New York City, W2XE. Programs sent over W2XE also follow those of the National Broadcasting Company and General Electric Company in that regular network programs are frequently broadcast with foreign language announcements and, in addition, special foreign language news commentators provide daily news summaries. W2XE also broadcasts a weekly woman's program in Spanish for South America, as well as a weekly theatrical review in Spanish.

Since the entertainment likes and dislikes of people differ from nation to nation, this must be taken into account when devising programs attractive to foreign listeners. There is not much point in broadcasting one of Jack Benny's programs to South America if the South American listeners cannot understand English. On the other hand, foreign listeners expect to hear American music and entertainment when they listen to America, rather than a repetition of the type of program they can tune in from their local radio stations. Trying to strike an average between these two



Announcing the station call at W3XAL's transmitter.



conflicting points naturally requires careful planning. At the present time, greater emphasis is placed on programs for South American listeners than on those for Europe due to the intensive radio drive which European nations are making for South American favor.

### What's Wrong with Our S-W Broadcasts?

Compared to the elaborate broadcasts sent out from Europe by the Government-owned stations, the American efforts in international broadcasting seem puny indeed. However, for Government-operated European stations, the question of operating expense may be completely ignored by the station operators, while in this country, where stations are all operated by private enterprise, with the sale of time on the air for advertising purposes forbidden by the Federal Communications Commission, the question of program expense looms very large in the s.w. station budget.

Nevertheless no one can claim with justice that the United States has developed a first rate plan of broadcasting to foreign listeners. In addition to lack of adequate program material many U. S. short-wave stations suffer from technical defects such as poor quality of transmission, haphazard use of different available s.w. channels without regard to their effectiveness in reaching a particular place at different times of the day and poor maintenance of equipment, causing such annoying faults as high level of hum on carriers and either  
(Continued on page 311)

Record of a recent address by President Roosevelt just before it was broadcast to South America over W3XAL. Translations of the speech in several languages were also recorded and rebroadcast.



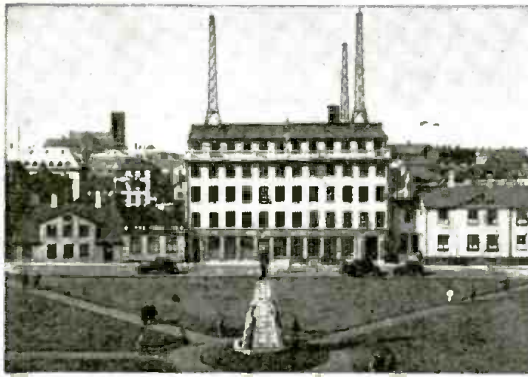

Station TFJ? A nice cool place to spend your vacation, for it's located in Reykjavik, Iceland. Scene on a public square is shown above, the central building with the towers being the telephone and broadcasting building.

Nini Marshall of station El Mundo, short wave program star of South America? Miss Marshall is famous for her characterization of "Catita," the little working girl, and also "Candida," the Galician maid-servant.

Gunnar Paulsson, the Iceland tenor? Numerous entertaining features are broadcast regularly by short wave from Iceland. Local listeners are entertained by long wave broadcasts.

# HAVE YOU HEARD—

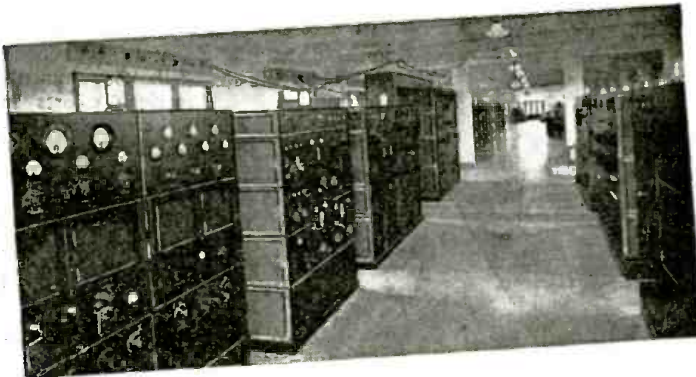

Tokyo? One of the powerful Japanese short wave transmitting stations, which also carries short wave programs heard by many American DX listeners.



Matilde Broders, the Chilean soprano, who sings exclusively for Radio El Mundo, the famous Buenos Aires short wave station? She is heard on the Toddy programs.



One of the unusual "Biwa" concerts over the Japanese short wave broadcasting stations, by Miss Kyokurei Tanaka and her troupe? The Biwa is a Japanese form of guitar.



Miss Senmaru and her group of songsters on one of the Japanese short wave programs? The instrument seen behind and to the right of the microphone is known as the Samisen and is used to accompany the singers.



# TALKING on 1-Meter Waves

C. G. A. von Lindern and G. de Vries

A telephone circuit between Eindhoven and Tilburg, Holland, which uses waves of about one meter (300 mc.) Triode tube transmitters and super-autodyne receivers are used. The directive aeri-als are of Yagi type.

● **RESULTS** of experiments made in the Philips' laboratories with waves of about one meter, have shown their practical value for communication purposes. With the collaboration of the Netherlands' postal authorities experimental telephonic connections have been established between Eindhoven and Tilburg.

In order to establish dependable radio connections with ultra-short waves, it is an indispensable requirement to be able to see the receiving aerial from the point where the sending aerial is located.

"Seeing" means in this case that the dipoles of transmission and reception have to rise at least ten meters (32 ft.) above all trees and buildings. The Eindhoven aerial is installed at a height of 72 meters (230 ft.) above the ground on the roof of one of the old Philips factories. The Tilburg aerial, which is on the roof of a local plant, was originally only two meters (6.4 ft.) above the building. The direct line of vision was interrupted by trees and the reception at Tilburg was rather weak.

In order to have two equivalent circuits, the receiving aerial at Eindhoven has been

mounted two meters (6.4 ft.) lower than the sending aerial. The two transmitters, at Eindhoven and at Tilburg, work on 1.4 and 1.23 meters respectively in order to avoid mutual interference.

At Eindhoven as well as at Tilburg, aeri-als of the *Yagi* type are used for transmission and reception. The *Yagi* aeri-als consist of a number of parallel rods, mounted on a plane, coupled electro-magnetically among themselves and also with the dipole which is connected with the transmitter (or receiver). The length of the rods and the inter-distances have been determined by experiments in order to achieve maximum strength. The device functions in such a manner that the signals which arrive from the desired direction, induce in the various rods electrical tensions, the resulting components of which add up in the rod connected with the receiver. By installing another rod (reflector) the signals which reach the receiver may have an amplitude which is 3.5 times greater than in the case of simply using one dipole. It is evident that the same figures may

(Continued on page 316)

3—Aerials at Tilburg. They are mounted between two ladders. The transmitting aerial is six feet above the receiving aerial. 4—Apparatus at Tilburg. Left-hand panel contains two receivers. The right-hand section is the transmitter. 5—Philips TB 1/60 tube used in the transmitter. 6—The upper aerial is the experimental Yagi type referred to in the article. To the right and lower down may be seen the standard aerial.

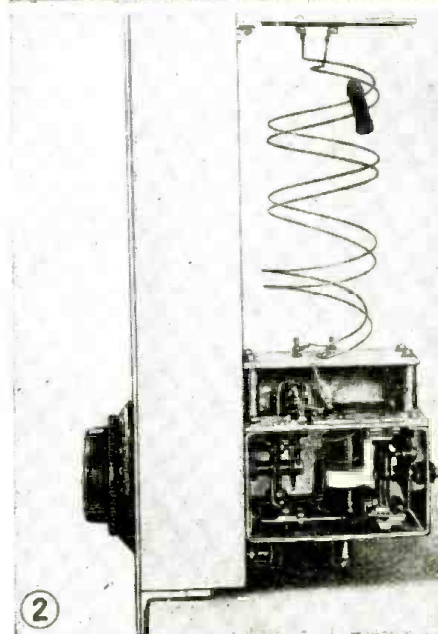
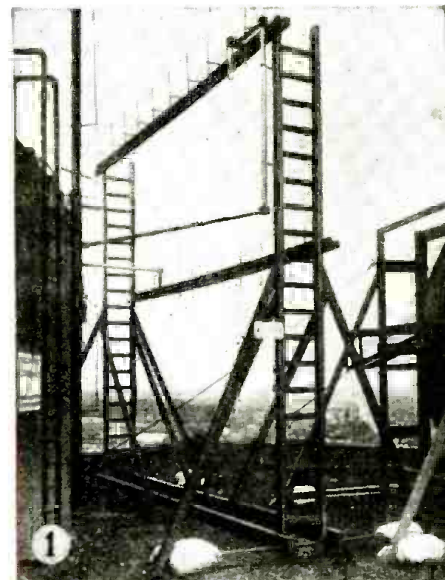
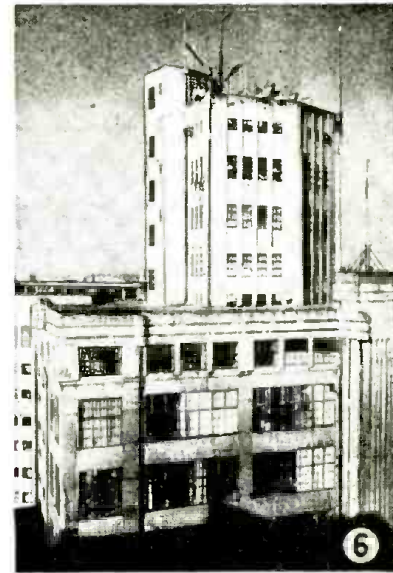
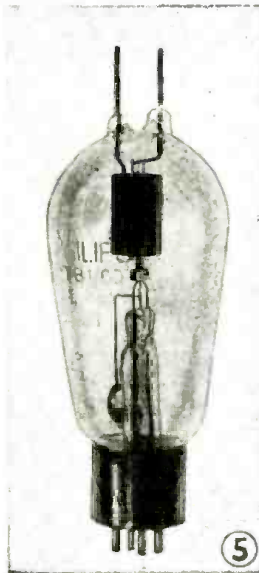
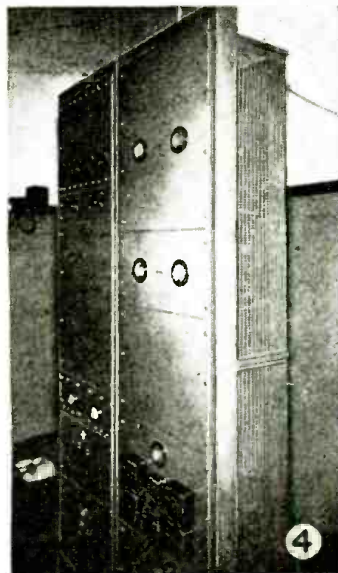
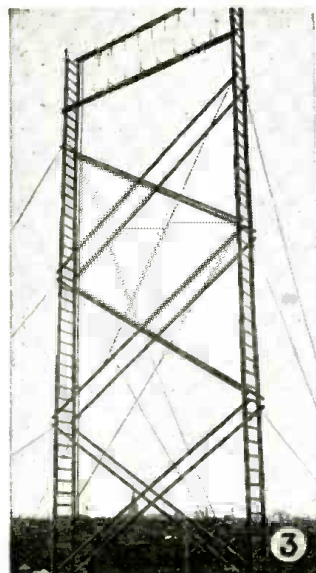

1—shows the aerial arrangement at Eindhoven. 2—is the oscillator-modulator unit of one of the transmitters.



# Radio Pilots Ships into Port

(Front Cover Feature)

● **TOSSING** about on the storm-swept fringes of the Atlantic, shut in on all sides by a thick blanket of fog that periodically settles about them, or cruising around outside the lightships on a calm sea under a full moon, the hardy pilots that bring the biggest liners and the smallest tramp steamers into New York Harbor now have the familiar telephone right at their elbows aboard their steamers, *Sandy Hook* and *New York*.

First contact with civilization on this side of the ocean for the incoming steamships and the last contact for outbound vessels, the trim little pilot boat is always a romantic sight.

A glimpse inside the snug wheelhouse of one of these little vessels now reveals a recent development of Bell Telephone Laboratories—the marine radio telephone. The little handset looks and acts just like the familiar telephone we are so accustomed to seeing and using in the home and the office ashore. Even the cheerful tinkle of the telephone bell contributes its assurance to the pilots and crew out there, so while they are actually out of sight of land, they are part and parcel of the United States. And it is just as easy for them to call a number in San Francisco as it is to call their own office ashore in New York City, for the marine radio telephone station operated by the New York Telephone Company on Staten Island serves as a constantly available link with the entire Bell System.

In days gone by, these rugged individuals



Top photo—One of the New York Harbor "pilot" boats equipped with short wave phone, permitting contact with shore or other boats.

Above—Capt. Woelfling talking on S-W phone aboard pilot boat "Sandy Hook." The boats can be "rung" selectively.

Even the harbor tug-boats have gone "short wave."  
Photos courtesy Western Electric Co.

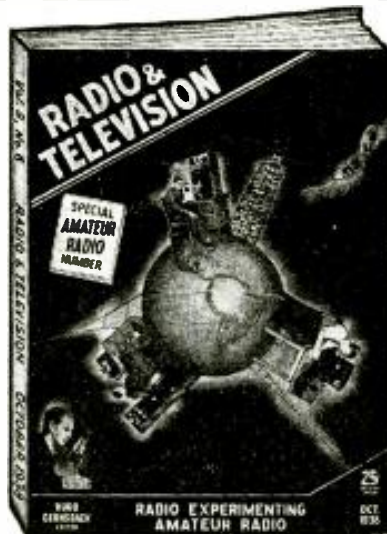

With the October number, *Short Wave & Television* will change its name to **RADIO & TELEVISION**. See inside front cover for details.

used to spend as much as a week or ten days cut off from civilization having no other contact with the rest of the world than the passing ships. Even now, each time one of their number goes over the bounding waves in the little dory to board an inbound ship, he takes with him a package of mail for points ashore, to be posted upon the arrival of the vessel he pilots into port. And each time one of the pilots brings a ship out, he carries with him a bundle of newspapers and letters for those he is to join aboard the pilot boat. With the advent of the early radio telegraph a "wireless operator" joined their ranks to tap out Morse signals on his key, accompanied by ery and ear-splitting flashes of blue fire.

These salty souls on the pilot boat then had telegraph communication with the outside world. With the steady march of improvement in the art, at last came the little

(Continued on page 317)

## Can YOU Answer These Radio Questions?

1. What are the wavelengths used in ultra high frequency broadcasting? See page 261.
2. In what simple way were the television scenes of the British "derby" switched from "close-ups" to "long-shots"? See page 262.
3. Can you name at least one defect in American short wave broadcasting? See page 264.

4. What is the Yagi type of ultra short wave aerial and how is it built? See page 267.
5. Are radio code or phone signals used to pilot ships into New York harbor? See page 268.
6. What are the names of the two electric fields surrounding a charged radio antenna? See page 269.
7. What do you have to do in order to win a VAC certificate? See page 275.
8. Can you name three leading S-W "catches" heard during the month? See page 276.
9. How would you connect a loop aerial for short wave reception? See page 287.
10. What is one of the principal features of

(Continued on page 302)



# Practical Antenna Theory and Application

Ralph L. Tedesco

The different types of aerials used for amateur transmitting stations, together with their feeder systems, are here described.

AS most radio amateurs are interested in the maximum power transfer of their transmitter to the antenna system, this article is intended to convey in the most practical manner, some of the theory relating to antenna systems and feeder lines.

A certain amount of reference to fundamental laws and principles will be necessary in order to fully understand the practical application of same, therefore, the accompanying figures and diagrams will be an aid to the beginner.

## Hertz Type Aerial

Figure 1-A shows the general make-up of an electro-magnetic wave as it leaves the radiating member. The components of the electro-magnetic wave consist of a magnetic field M and an electro-static field C. Figure 1-A is known as the Marconi type of radiator. Figure 1-B is known as the Hertz type radiator. Note that the wave formation on either type is identically the same, except for the fact that in the Marconi type one-half of the wave formation takes place below the ground, while on the Hertz type both radiating members are above ground; therefore, the entire wave formation takes place above the ground. The Hertz type of antenna is the most popular, and, as it is used for short-

wave work, our attention will be centered on that particular system. There are various forms of Hertz antenna systems, each having different methods of feeding the antenna proper with adequate and efficient feeder lines. The accompanying figures show how these feeder lines can be applied. See figures 2-A, B, C.

## Feeder Line Theory

Feeder lines should transfer power and not radiate.

Radiation of feeder lines is caused by standing waves.

Standing waves are caused by reflection, and reflection is the result of improper termination of the line.

Feeder lines fall into two classifications:

1. Open wire type properly spaced and running parallel with air between them as the dielectric, and wires crossed at intervals, so-called transposed lines. There is also the twisted-pair with other forms of insulation rather than air. They have considerable dielectric losses.
2. Concentric shield conductor, a wire surrounded by a sheath of metal such as tubing or metal braid with either a solid material as the insulating medium, or air. Air of course being the best type.

(Continued on page 310)

The diagrams below and at the right show some of the principal types of antennas and feeders suitable for amateur stations.

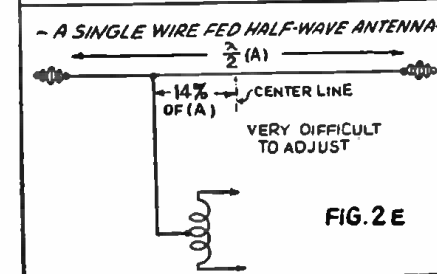
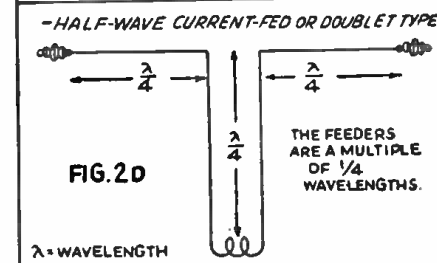
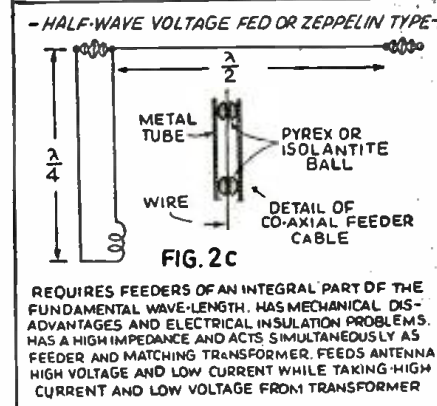
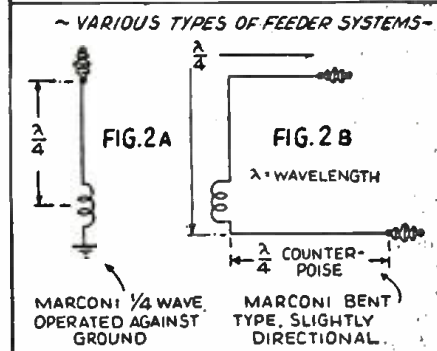
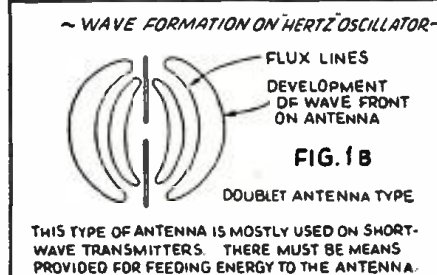
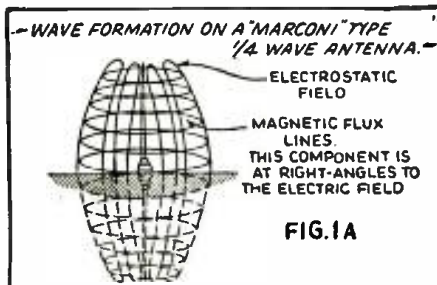
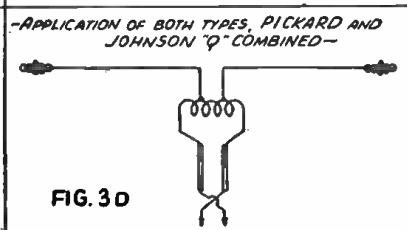
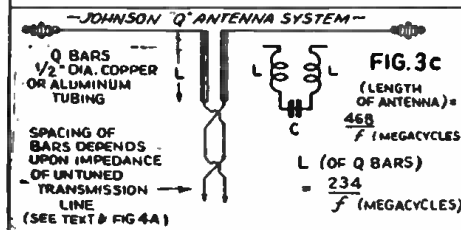
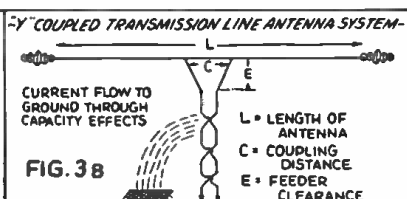
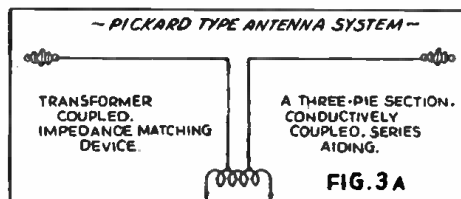
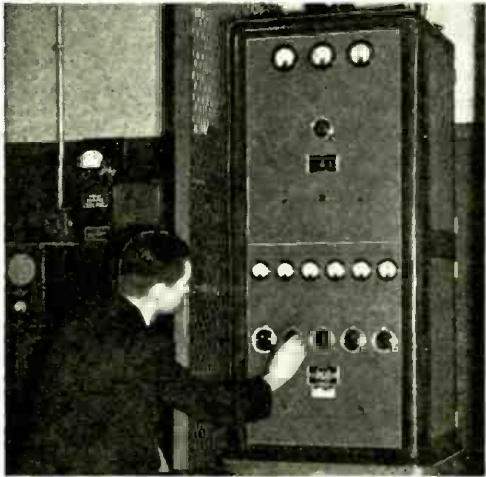



Photo shows new short wave transmitter and receiver carried by mounted English policeman, which keeps him in constant touch with headquarters, mobile police cars and even airplanes. A similar set is used by cavalry officers in the American Army.



Televising a feature play at the NBC studios in New York. The play is "Susan and God," starring Gertrude Lawrence and Paul McGrath. As soon as the NBC television transmitter goes back on the air, which will probably be this fall, other studio plays will be televised, together with film plays and other features.



Left—Ultra-short wave transmitter operated under the call letters W2XJI by Station WOR. It is installed atop a 24-story building. The operating frequency is 26.3 megacycles and the carrier power is approximately 100 watts.



Left—How book leaves are turned for a television presentation over the NBC system. Each leaf is turned by means of a wire projecting down through the shelf and out of the focus of the television camera. Note the artistic spider-web effect used in this setting.



Right — Television in England. This is a shot of a B.B.C. television mobile unit in operation; the television camera is picking up an important English sporting event.



# W8XWJ Broadcasts on 7.3 Meters—with 14 Hour Daily Program

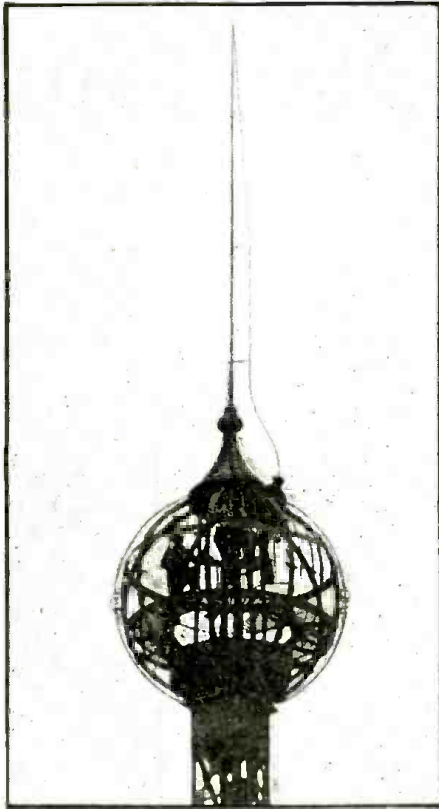

Above—Installing vertical radiator and concentric transmission line atop the Penobscot Building—the tallest in Detroit.

Right — W8XWJ's engineering staff: T. Pennebaker, E. J. Kelly, C. H. Wesser and C. Leedy.

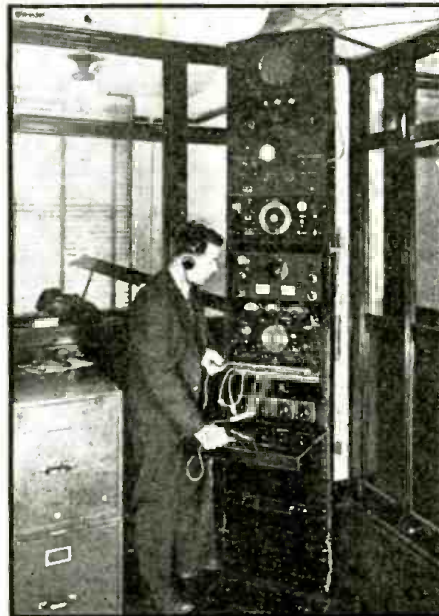

Engineer E. J. Kelly checking receiver panel.

● PROHIBITED from deriving revenue from ultra-high frequency broadcasting, radio stations have operated their ultra-high transmitters for experimental purposes only and with no regard for size or type of audience. In most cases the programs going out over the regular broadcast band have also been fed into the ultra-high transmitters. With comparatively few listeners whose receivers are capable of ultra-high reception and with even these choosing the more familiar standard frequencies, ultra-high frequency broadcasting has had only a small audience. It took W8XWJ, owned by the *Detroit News*, also owner of pioneer broadcasting station WWJ, to change this situation.

W8XWJ began its career as an *ultra-high frequency* station in February, 1936, operating in conjunction with WWJ. It was equipped with a 100 watt transmitter, located on the 44th floor of the Penobscot Building in Detroit, coupled through a  $\frac{7}{8}$  inch coaxial transmission line to a vertical half-wave radiator on top of the

beacon tower 680 feet above the ground.

In January, 1938, W8XWJ installed new and more powerful equipment and began operating under an entirely new policy with the aim of building up a large and faithful listening audience. As a principal means of reaching this goal it began broadcasting on a full schedule of 14 hours a day.

A complete program and technical staff  
(Continued on page 307)

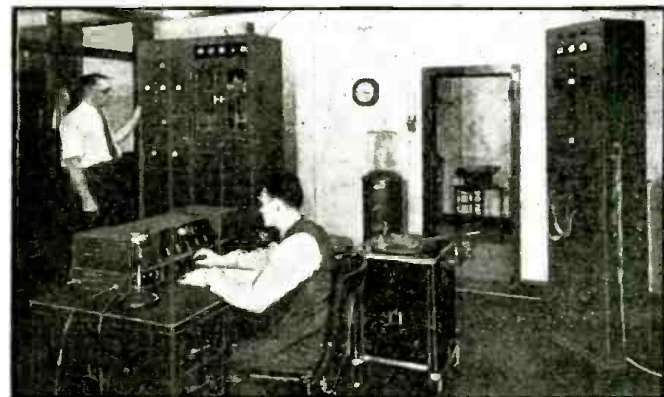

Left — C. Leedy seated before the control console and C. H. Wesser before the high frequency transmitter.

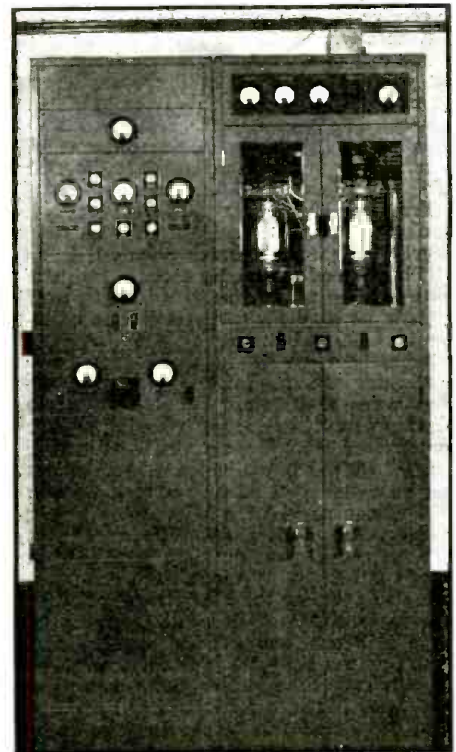

Right — Close-up of the ultra-high frequency transmitter and 500 watt amplifier.



Earl D. Phillips is the "pilot and air engineer" of the Flying Club of Kingston, Ontario, Canada. Receiver used is a National NC-80-X receiver, for short-waves; also he has a Stewart-Warner R-145 and a 5-tube T.R.F. home-built job.

### Another Dissenter

Editor,

I just purchased your magazine from a newsstand and find it extremely interesting as well as educational. Let's hope it doesn't turn into a picture magazine!

In this June issue I notice a page titled, "What Do You Think?" and I see an article addressed to the Editor by a Mr. Fiege. If agreeable, I'd like to answer Mr. Fiege as follows:—

Well, my smart Naval Reserver, Mr. Fiege, just how do you figure out a way to show proof of a two-way QSO without a QSL? As an experiment I called in quite a few passers-by to listen to some real DX, and 7 out of 10 of those people made the comment that the program was originating from a local source and it was only by showing verification by card, stamped and dated with the country's post-marks that I convinced those ordinary BCB listeners that I wasn't pulling a fast one on them. So it isn't such an antiquated thing at that to receive or send SWL or QSL's.

Naturally, we do not get a QSL for a phone call to Chicago or where have you, but you get a bill for it. Personally, here from N.Y.C. I do not SWL or QSL an amateur unless he is in the W5-6 or 7 area or in a foreign country. But as a matter of courtesy, I answer anybody 100% that asks for an exchange of cards.

True, by showing a flock of cards it won't help get a license, but did you ever figure out that by contacting various hams who have good outfits, an embryo ham can learn a lot on what equipment is being used or how he may improve conditions existing at his shack?

Recently I wrote an article for QST concerning the failure of hams to QSL, even when they asked for reports as to whether or not they were "getting out" but couldn't raise an answer. In that article I called those hams a bunch of bum sports and cheap skates. Also I condemned the ham who uses ½ or a kilowatt of power and spends hours talking on the air without a let-up and drowns out anyone who can't overpower his rig. Without any exceptions, that also goes for the Navy "ops" who use a 5 kilowatt battle-wagon (warship) rig on the ham bands, and I'll lay you 100 to 1 it isn't on the logs who was contacted. I've not only called them and QSO'd with them while they did it, but I've ordered them to close down and that as an army operator both in the Signal Corps and Air Corps

# What Do You

while operating as an interceptor station. That would be called real bootlegging in my opinion.

Also, for your information, a genuine SWL card is not made out like a QSL; for instance, between the prefix and the number and the SWL part is a hyphen—re: -W2-SWL—that's clearly enough proving that it is *not* a call letter!

You'll find also that the real ham who hasn't commercial or military operating on the brain and some of their plain crazy regulations, has his shack covered with QSL cards, and is proud of them as an achievement as well as having the well wishes of his host of unseen friends.

By the way, those regular Navy hams in the Canal Zone put out some good QSL's and don't seem to be so modernistic in regards to doing it as the Reserves, when it comes to sending them out! Hi!

L. F. GALLAGHER,  
Ex-W2IDTV-W2DIU-WYA5,  
(U. S. Air Force Operator),  
307 East 17th St.,  
New York City, N. Y.

### Suppress Those Ignition Waves, Say He!

Editor,

I am a constant reader of your F.B. magazine and an ardent S.W.L. I take great interest in this department and my point in writing you this letter is to bring up a matter which, most certainly is of vital concern to all of the "gang" who are unfortunate, like myself, in that they are residents of cities.

My question is, "Must we poor QRM dodgers always have to contend with these diabolical auto ignition systems?" It does seem that there could be some legislation brought about to rectify this ever annoying source of preventable interference.

Just as that much sought after DXer is announcing his call always seems to be the chosen time for some one to drive his "pesky hack" past the shack. I appeal to you as a fellow enthusiast, "Isn't there sumthin' that kin be done about it?"

I should be very interested to find out just what the rest of our vast number of SWL's have to offer concerning this matter. What do you say, fellows, can't we just get together and lynch these noisy car owners or should we just try to get laws passed making ignition suppressors compulsory?

FRANKLIN JARVIS,  
249 Auburn Street,  
Auburndale, Mass.

### Wants More "Amateur Course"

Editor,

After reading George B. Thompson's letter in the April SHORT WAVE & TELEVISION, I thought I would submit my two cents' worth.

I agree with him completely in his plea for more *Amateur Course*. Personally, I

know of about five people who would appreciate simply-worded radio theories in such a form. While your other "Amateur Course" was excellent, I would like to have seen superhet, action, volume expansion, etc., explained more completely.

I think Joe Miller's column is a dandy but would it be possible to give a corner to a forecast of stations likely to be heard for the following month?

How about conducting a vote on whether you should have television articles or not? I think that while this may interest people around New York, where television is being tried, yet more people would rather see constructional articles on receivers, pre-selectors, etc.

HERB AGNEW,  
113 Garden Crescent,  
Calgary, Alberta,  
Canada.

*(We're trying to please all of our readers, but we shall be glad to hear more about that "Amateur Course." Television is advancing so fast that we feel most readers will welcome the opportunity to study up on the subject.—Editor.)*

### A Neat Listening Post

Editor,

Herewith is a picture of my short-wave receiving station. The receiving equipment is mounted in a bookcase frame. The receiver on the second shelf is a Hallicrafter "Sky Buddy". On the lower shelf at the right is a T.R.F. receiver using 2-volt tubes; on the left is a 1-tube set using a dual purpose tube. On the top is a self-excited transmitter that I intend to use as soon as I get my Ham "ticket" (license). I also have a crystal-controlled rig.

I enjoy your magazine very much and buy it at the newsstand. I think the Kink and Question Box departments are swell. I am a member of the *Short Wave League*.

I would be very pleased if you would mention in SHORT WAVE & TELEVISION that I would be pleased to correspond or exchange photos of my short-wave listening station with SWL's anywhere.

DONALD WINSLOW,  
89 Lewiston Street,  
Mechanic Falls, Maine.

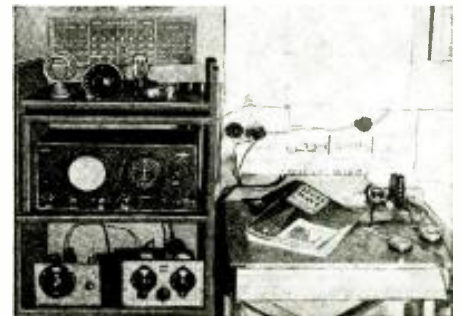

A Hallicrafter "Sky Buddy" receiver graces the listening post of Donald Winslow.



# Think?

From an Ex-Signal Corps Major

Editor,

I have just finished reading Mr. Fiege's letter published in the January issue of *SHORT WAVE & TELEVISION*, and allow me to congratulate him on being the most egotistical person I have ever heard of. It must be fine for you to think you are so well informed about radio that it is too much trouble to try and help the young boys who are interested in radio.

After reading your article for the second time, I wonder that if there was ever a time in your younger life, that is if you ever had one, that you enjoyed listening in when you were unable to have a real rig, and receive QSL cards from persons you heard, or maybe you are the type that always has been able to have everything you craved; your article would make one think that. You remind me of the kind of a person that has forgotten your younger days, and have gotten to the stage that you find it fun to stick pins in babies or some other mean way of enjoying yourself.

As for you having been in radio for a number of years, I still think you have a lot to learn. These young boys whom you write about, without a doubt save all they are able to save to buy SWL cards and are very proud to be able to send them. As for radio, may I advise you that I have been in it also for a number of years. In 1916 I was Chief Operator on a tanker, and during the World War, which I suppose you were too young to be in, or else had too much money to go, I was a Major in the U. S. Signal Corps, but I am still young enough in mind to try and help young boys just starting in radio.

J. A. BURNS,  
New York City.

## Travels 25 miles to get S.W.&T.

Editor,

I have been a reader of your publication for two years now, and I want to congratulate you on this fine magazine. I get them about a month behind, but it's worth waiting for. Then I have to travel twenty-five miles to town to get it. I would not be without it. It's R9 from start to finish. Joe Miller's column is "F.B." His tips have added many QSL's to my collection! I always like to read "What Do You Think?"

I am a member of the *Short Wave League* and I prize my certificate. My pals desire one, so I am filling in the "Nomination for Membership" form and sending it along.

Well, back to short-waves! I have a new receiver now—the Hallicrafter's "Sky Buddy" and does it wallop in DX! American broadcast S-W stations come in R9—QSA5 on the loud-speaker. My antenna is a doublet in the attic. I've heard 670 amateurs on 20, 40, 80 and 160 meters. I've heard 42 countries, all six continents. Among the countries I've heard are U.S.A. (seven districts), Cuba, Hawaii, Dominican Republic, Java, Brazil, Ethiopia, Arabia, Morocco, Tunisia, Australia, Canada,

Prize Winner this month—I year's subscription to S. W. & T.—Theodore Domby, 3514 Hartford St., St. Louis, Missouri. Mr. Domby has a great collection of QSL cards, as the photo shows. A pair of headphones prove useful in landing those elusive DX stations.



Chile, Japan, China, Mexico, Venezuela, Egypt and many others.

Up till now my 20 meter log is 400  
my 40 meter log is 250  
my 80 meter log is 15  
my 160 meter log is 5

—  
670 Hams

Broadcast *short-wave* stations, 150; there's lots more I've heard. Only foreign language makes it difficult to understand; for instance, the Latin-Americans. They talk so rapidly, you have to know your Spanish in order to log them.

As I write this letter my receiver is tuned to W3XAL, 16.87 meters. He's putting over a good signal R7, QSA4. The program is a "news bulletin." Well, here is news to me. The mail has just come and I've two veris from Batavia and Java, for PLP, 22.27 meters, and PMN, 29.27—am I proud of these! Yesterday I received SM5SX veri from Stockholm.

Back to Hams—the one I like is W2IXY, operated by Miss Dorothy Hall. She certainly has a swell rig. She comes in R8 on the loud-speaker. I heard her QSO with G2UT, 5YV, 6RF, 2A1, HK5AR and lots more. I would like her QSL.

J. V. DAVIS,  
Church Erstone,  
Oxfordshire, England.

## How to Understand Spanish Speaking Announcers

Editor,

I've only been DXing for the past 8 or 10 months, but I have rolled up some fair DX, considering my noisy location I am unfortunately in. I am using a rebuilt 6 tube superhet, having added a bandspeed dial, new communications type cabinet, beat oscillator, and miscellaneous other improvements, and scan the 20 and 40 meter "ham" bands on both C.W. and phone. Here is the 20 meter DX heard: CE, CM (O), CN, CP, CR7, CH1,2, CX, D, EA8,9, EI, ES, F, FA, FB8, FP8, FT4, FY8, G, GM, GW, HA, HB, HC, HH, HI, HK, HP, HR, I, J2, K4, 5,6,7, KAI, LU, LY, NY, OA, OE, OH, OK, ON, OQ5, OX, OZ, PA, PK, PY, SM7, SP, SU, SV, TF, TG, TI, U2,3,9, VE, VK,2,3,4,5,6,7, VO, VP1,2,3,4,5,6,7,9, VS2,7, W10, YL, YN, YR, YS, YV, ZC5, ZE, Z1,1,2,3,4, ZS-T-U1,2,3,4,5,6.

I've also verified the following, but hope more are on the way: CE, CM, CX, D3,4, EA9, F8, G2,5,6,8, GM6,8, GW5, HB9,

HC1, HK5, K4,5,6,7, LU1,2,3,4, LY1, NY1, 2, OA4, OK2, ON4, PAO, PY2, VE, VK2,3,4,5,6,7, VP3,5,6, VS7, YR5, YV3, ZL1,2,3,4, ZU6, XE, and W of course.

A few of my "ace" phone veris are VS7GJ and EA9AH, with VK3AL.

I use a 32-foot, 20-meter antenna directional E. & W., and 50 feet off ground. On 40 meters have heard K6, CM, TI, YV, NY and K5, but I DX mostly on 20, as DX is usually much better. This year I have received 141 cards from about 35 countries on the amateur bands to date, and have found that the most interesting and thorough report "brings home the bacon." Incidentally, will exchange dope and cards with any other SWL's.

On closing, I need not say what I think of S. W. & T., because every radio hobbyist knows it *takes the cake*. Also, let me give my 73 to Joe Miller, and may he keep up the precise and snappy DX reporting we all like.

And as to the SWL's who kick about the South American stations for their announcing, I would advise them to invest in a copy of the Spanish alphabet and number list, and to memorize them. I found that it pays!

R. H. NEWKIRK,  
Pres., Fargo DX Club,  
V.A.C. ('phone-c.w.),  
1517 Fargo Ave.,  
Chicago, Ill.

## Another Brick

Editor,

Three cheers for Jim Lydon and the "brick" he threw in a recent issue.

I don't believe that there are "quite a few" readers interested in your television articles as long as there is no possibility for them to build a television set.

I am a subscriber of your magazine since 1933; and I would repeat what Jim Lydon wrote, "look over the '34 or '35 magazines."

We are not much interested in television or S.W. diathermy but I think we all are interested in radio. So, why do you never try to give the gang constructional data about the developments in radio circuits: amplified A.V.C., A.F.C., etc?

What about a tiny 50 watt Phone Xmitter using receiving tubes? 73 and best of luck.

DR. R. ESSINGER,  
Corseaux, Vand.,  
Switzerland.



# The Short Wave League

## HONORARY MEMBERS

Hugo Gernsback, Executive Secretary

Dr. Lee de Forest  
D. E. Replogle  
John L. Reinartz

Manfred von Ardenne  
E. T. Somerset  
Hollis Baird

## On the Ham Bands (with the Listening Post Observers)

Edited by  
Elmer R. Fuller

● WELL, here we are with a new department, provided for the use of hams and fans who wish to see their accomplishments in print and to feel that they are contributing something to the world of short wave radio. Henceforth, this will appear as one of the many features in every issue.

The purpose of these pages will be to provide the reader with the information as to the stations and countries being heard on the amateur bands in all parts of the world. It will serve to tell the amateur where his signals are being heard and how he is being received.

At the present time, twenty-nine observers have been appointed. A short time ago, over a hundred letters were sent out to persons who were believed to be interested in this type of service. Of these, thirty-two replies have been received. Several were sent to foreign countries and have not yet had time to reply. The ones appointed to date, and the states which they represent, are as follows:

Bayer, Ray.....Wisconsin  
Bohlender, Homer.....Ohio

Catchim, D. S.....Virginia  
Croston, Wilbur.....Ohio  
Drake, Walter F.....Pennsylvania  
Davenport, E. H.....Vermont  
Fitzpatrick, John.....New Jersey  
Gallagher, L. F.....New York  
Honda, Harry.....California  
Haas, Garland A.....Indiana  
Herzog, W. F.....New York  
Hatcher, Robert.....Virginia  
Hernday, Raymond.....Wisconsin  
Hartzell, Clarence.....Pennsylvania  
Jordan, Thomas P.....Pennsylvania  
Kemp, H.....Connecticut  
Legge, Roger, Jr.....New York  
McKinney, David.....Tennessee  
Markuson, Earl S.....Colorado  
Newkirk, Rodney.....Illinois  
Roehl, Raymond J.....Minnesota  
Robinson, Hugh.....Oklahoma  
Russell, G. H.....Pennsylvania  
Skinner, William.....Michigan  
Shepherd, Owen, Jr.....Connecticut  
Wood, James R.....Minnesota  
Wallen, Dan T.....Colorado  
Clarke, Stanley.....Quebec, Canada

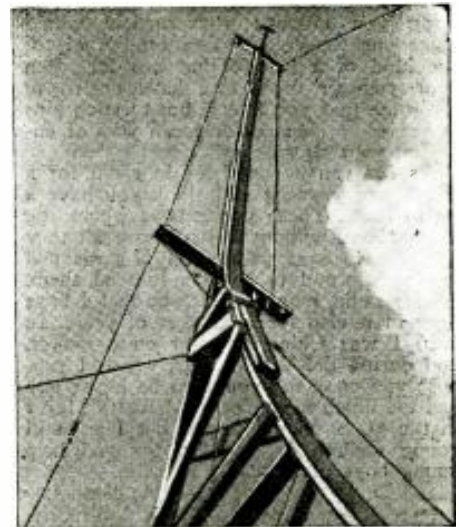

A "worm's-eye" view of the 20-meter vertical antenna used by S-W listener Robert Hatcher, Richmond, Va.

Certificate of membership in the "NRH Fraternal Order" sent to listeners by Amando Cespedes Marin.



During the coming month, I would like to add a few more to this list, particularly from the Southwest. This section of our forty-eight states seems to be missing entirely. Send your applications to Elmer R. Fuller, 32 Madison Street, Cortland, New York. All correspondence will be answered personally.

According to information received here from Clarence Hartzell, Observer for Pennsylvania, the Mexican ama-

teur, XE1GE, is only licensed to use the 10-meter band. However, he has been using the 20-meter band for testing. This is because of the inactivity on the 10-meter band at this time of the year. The operator has made an application to the Mexican government to continue to use the 20-meter band for the rest of the summer.

To Robert Hatcher, Observer for Virginia, goes some kind of a record. At least we have never heard of it being done before. On June 6th, in about five hours time, all continents were heard! These were all on phone except one, Palestine. The stations logged were:—OX2QY on Greenland, K7ACO in Alaska, ON4AN in Belgium, CN8AV in Morocco, ZC6AQ in Palestine, and VK2HS in Australia. Mr. Hatcher reports that these are the best received from each of these countries.

Observer Hatcher also sent us the following report on stations which are now being heard almost every day on 20 meters:

GW5TJ—Wales, often heard around 6 p.m., E.S.T., with power of 150 watts.



Signals are very strong and are found near the high frequency end of the band. QSL's one hundred per cent for correct reports and the usual international reply coupon.



Listening post of Robert Hatcher in Richmond, Va.

GI5QX—Northern Ireland, often heard around 1 a.m., E.S.T. Has power of 50 watts. Also listen for GI2AK, GI2CC and GI8LW.

GM6WD—Scotland, heard about 11:40 p.m., working VP1BA. Has a very good signal. Also, GM5NW, GM6BW, GM8RG, and GM2CC.

E12L—Irish Free State, came in S5-8 about 5:55 p.m., working West Indies. Also look for E12J, E16G, E18M and E14L.

In June, the French transmitter, F8ZS, was heard at 1:47 a.m., while calling ZB1J in Malta. The power being used was only 20 watts.

A Portuguese station which may be very easily heard is CT1AY. He is on almost every evening from about 5:30 to 7 p.m. Signals are usually S7-8. He will not verify reports of reception.

The Palestine station mentioned above was heard on June 2nd when it was QRM'ing YR5RC. This is one of the very few stations located there and none of them are on phone. So, if you want to log this country, you will have to turn to cw.

Observer Roger Legge, Jr., of Binghamton, New York, reports hearing PK6XX in Dutch New Guiana. It has come through several times and with very good signals between 6 and 7 a.m., E.S.T. The frequency in use is 14.02 megacycles. Mr. Legge also reports that VR6AY is still being heard occasionally on 14.368 megacycles. This was most recently heard at 3:30 a.m., E.S.T. VS2AE has been reported as being heard at 5:30 a.m. on 14.37.

Yours truly purchased a new receiver a short time ago and set out to see just what could be done in two weeks' time on the 20-meter band. The opinion has been expressed by many that the dx could not be pulled in during the summer months when the QRM and QRN is extra heavy. Here are the stations logged during this two-week test period. It includes nineteen countries besides the United States, all five of the Canadian districts, and six of the United States districts.

Time	Call	S or R	Country
8:40 p.m.	YV5ABQ	7	Venezuela
11:29 p.m.	CO2LY	9	Cuba
12:39 a.m.	G6BY	6	England
5:30 p.m.	GM6RG	7	Scotland

6:52 p.m.	VP9R	9	Bermuda	12:10 a.m.	VE5ACN	9	Canada
10:55 p.m.	HI3N	8	Dominican Rep.	8:09 p.m.	WIHKK	9	United States
6:19 p.m.	PY2BJ	8	Brazil	12:40 p.m.	W4ECP	7	United States
7:21 p.m.	VO6D	9	Newfoundland	11:12 p.m.	W5FNA	9	United States
7:40 p.m.	GW5TJ	6	Wales	10:50 p.m.	W6OSY	9	United States
5:13 p.m.	CP1QH	7	Bolivia	11:50 p.m.	W7AKO	8	United States
5:17 p.m.	F3CP	8-9	France	5:43 p.m.	W8NDN	8	United States
5:19 p.m.	CT1QG	8-9	Portugal	6:58 p.m.	W9SSM	8	United States
7:14 p.m.	ON4AU	7	Belgium				
6:59 p.m.	VP1BA	8	British Hon.				
6:34 p.m.	K6OQE	7	Hawaiian Is.				
4:38 p.m.	VP3AA	7	British Guiana				
4:57 p.m.	PA0AA	6	Netherlands				
9:24 p.m.	VE1BK	8	Canada				
6:32 p.m.	VE2AA	8	Canada				
5:36 p.m.	VE3AHA	7	Canada				
12:04 a.m.	VE4UD	9	Canada				

#### 10 Meter Tests

A series of daily tests transmissions will be sent out by the stations listed below during the summer months. Their purpose is to obtain data as to the effects of barometric pressure, moon phases, etc., on radio

(Continued on page 311)

## Here's the New VAC Certificate

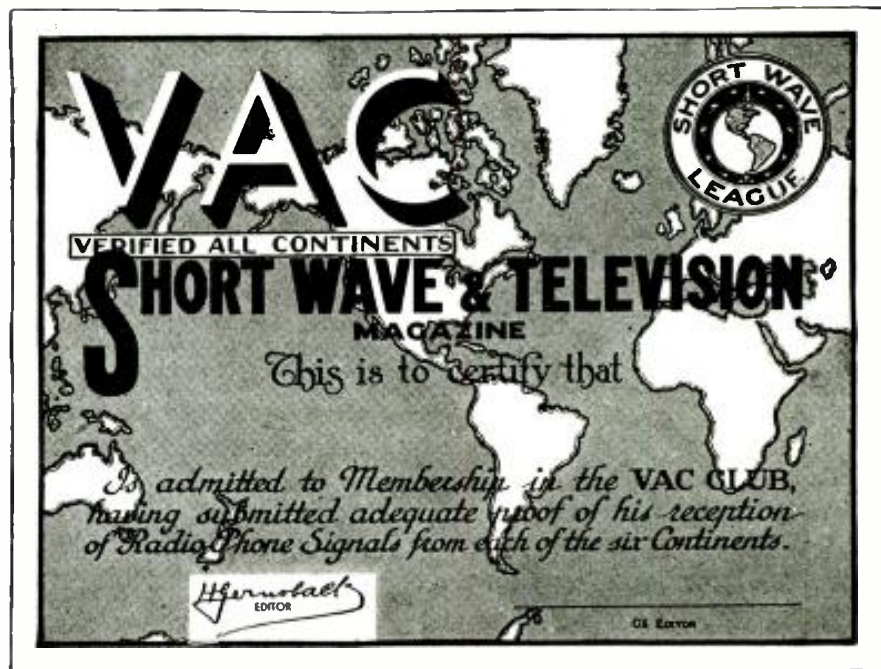

A reproduction of the new VAC certificate. The certificate is printed in black on a blue background on heavy ledger paper, 8 1/2" x 11" in size. It is quite a handsome affair and we are sure that listeners will be proud to display it.

● SHORT WAVE & TELEVISION has prepared a handsome VAC (Verified All Continents) certificate which will be issued to all short-wave listeners submitting adequate proof of verification from all continents. To secure a VAC certificate the listener must send in a verification card from each of the continents. The VAC certificate will be issued for verifications of broadcast stations and amateur or commercial stations transmitting voice or music. The certificates will be signed by the dx editor and Hugo Gernsback, Editor-in-Chief of SHORT WAVE & TELEVISION.

It is advisable that the cards be sent in a neat package and insured for safe delivery. All cards submitted will be returned. The listener should enclose return postage.

A nominal charge of twenty-five cents (25c) will be made for the certificate to

cover the cost of handling and printing. The dx editor will be the judge as to whether the verifications submitted are bona fide.

A special seal will be available for attaching to the certificate in the event that a listener has more than one complete set of verifications from all continents. A seal of this type will be issued for each complete set of all continent cards so that as ones VAC collection grows, it may be certified by affixing a new seal to the certificate.

The dx editor will also judge whether the verifications that are submitted for the seals are bona fide. The charge for the seal service will be ten cents.

All entries should be made to the VAC Editor, SHORT WAVE & TELEVISION, 99 Hudson Street, New York, N. Y.



Here's a fine foto of Rene—our DX friend certainly is hale and hearty!

F18AC—French Indo-China. Rene sends this outstanding QSL, with green letters, orange border.

Let's Listen In With

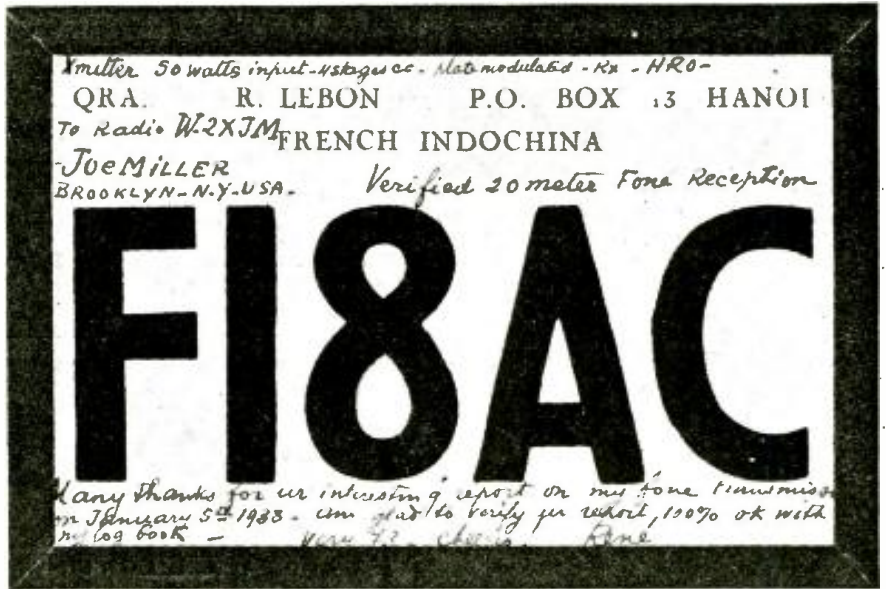

● MENTION has been requested, and duly deserved, too, of the NAPRI, the National Association for the Prevention of Radio Interference. Requests were made by both G. C. Gallagher and Max P. Fisher, President, and Executive Sec'y, respectively, of the Golden Gate Chapter of the International Ncxers Alliance (I.D.A.), H.Q. in San Francisco.

As this is a problem every ncxer faces in the daily operation of his rx, little explanation is necessary as to the aims of this fine organization, solely devoted to the purpose of eliminating all man-made QRN, in order to improve world-wide reception.

Mr. Gallagher mentions that his Golden Gate chapter is fully enrolled in this organization, and is sponsoring a campaign to procure state legislation affecting such interference, which he adds "will be similar to legislation in Oregon, Washington, Vermont, the territory of Hawaii, etc.!" Maybe we haven't read the papers or mags. lately, so it is with some pleasant surprise that we hear that official cognizance of this increasingly bothersome problem has been taken by state governments! With such achievements already behind it, the NAPRI will undoubtedly do a great deal more to better the reception of short waves.

Therefore, we urge ncxers everywhere, and to officials of radio clubs, etc., to write Mr. Carter, NAPRI, Flushing, L. I., New York, offering their aid in combating short wave's greatest problem.

#### FED. MALAY STATES

ZGB, 13.63 mc., at Kuala Lumpur, was heard with an R7-8 signal early this month,

at 5:35 a.m., when it was heard with the finest signal strength and clarity ever experienced here. A man was calling what sounded like VVS, which station's carrier was also on, and clearly giving call as "ZGB," but VVS did not answer. The usual slight flutter evident on all Asiatic phones here on the East Coast made intelligibility somewhat less than 100%, but ZGB's signal strength did give us a thrill! "Us" is fitting, as our old dx friend, Murray Buitkant,

now the "Bronx Nite-Owl," was keeping a dx watch with us in our ol' dx shack this particular a.m. Watch for ZGB near 5:30-6 a.m., occasionally also heard up to 8 a.m., this in winter. QRA: Radio ZGE-ZGB, Chief Engineer, Kuala Lumpur, Fed. Malay States. Oh, yes! A late tip. When calling, ZGB uses clear speech, but after contacting, reverts to scrambled speech, as is usual with commercial phones. ZGB also heard later at 6:45 a.m.

#### FRENCH INDO-CHINA

FZR3, 16.20 mc., at Saigon, was again heard, after a long absence, at 6:35 a.m. while in contacting with their usual station, FTK, 15.88 mc., at St. Assise, France. FZR3 was using clear speech, as was FTK. This is unusual, as inverted speech is the usual fare, once these two have contacted. FZR3 has an unusually rapid flutter here. This should be of great aid in identification. FTK should be watched, for when FTK is on, FZR3 may be also heard. FTK has an outstandingly powerful signal. 6:35 a.m. is rather early for FZR3, which usually is heard in the vicinity of 8:30 a.m. However, FZR3 is occasionally heard anywhere from 6-8:30 a.m. QRA: FZR3, Centre Radioelectrique de Saigon, Postale Boite 238, Saigon, French Indo-China, this from an FZR3 veri. FZR3 also heard one a.m. at 6:45, when it was Xinting a tone whistle; using several different notes, this used before FZR3 begins foning, so look for the tone whistle, too!

Radio Saigon, now called Radio Boy-Landry, was an R5 once, at 5:45 a.m. This catch should be heard this fall. Freq. 11.69 mc.

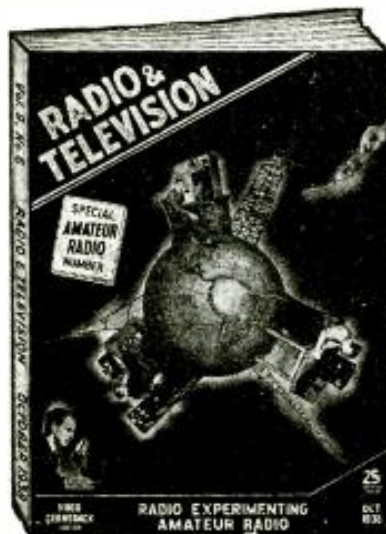

With the October number, *Short Wave & Television* will change its name to **RADIO & TELEVISION**. See inside front cover for details.



*Joe Miller*  
 "DX" Editor

**NETHERLANDS INDIES (JAVA)**

Good news!! Java is once again confirming reports on their commercial radiophone stations!! A new Chief Engineer, Ir. P. C. Arends, has answered several of our reports with the usual buff veri card, confirming our reception of YCP and PLQ, and is very obliging, sending us two separate QSLs for differently dated reports on PLQ. The QRA is: Ir. P. C. Arends, Engineer-in-Charge, Java Wireless Stations, Bandoeng, Java, Netherlands East Indies.

PLP, 11 mc., and PMN, 10.26 mc., are rolling in now as never before, PLP reaching R8-9, and PMN a good R6 here, both easy to log.

PLV, 9.415 mc., Bandoeng, the relay station for all other Javanese commercials when contacting the home country, logged at 5:50 a.m., relaying a Xmsn of YBG, 10.43 mc., Medan, Sumatra. PLV is one fone that cannot be missed, always an R7 or better, using the highest power of any commercial fone extant, a full 80 KW.!

PLQ, 10.69 mc., Bandoeng, has been heard at up to R9, in contact with YBG, from 5:50 a.m. up to 6:45 a.m., though PLQ

- KAICS—Philippine Islands—A very unusual card from O. M. Frank; many thanks, OM!
- J2NF—Japan—A fine card with deep green letters, on lightly shaded background.
- ZU6AM—South Africa—A handsome QSL indeed, red letters on yellow card. Thanks, Jack!
- ZE1JY—Southern Rhodesia. Billy sends us a distinctive card in black and white.

has been logged up to 8 a.m., this in winter. PLQ is very active now, so get after it, and watch for YBG, on almost daily, and a FB new country for most all!

**ITALIAN AFRICANS**

IUD, 18.27 mc., at Addis Ababa, Ethiopia, was heard at 6:35 a.m., with a good R6-7 signal, calling Massawa, Eritrea, probably through IDU, at Asmara. All the Italian fones use clear speech, except IAC, 17.70 mc., Coltano, Italy, which lately has adopted inverted speech.

Watch also for IUG, 15.45 mc., also at Addis Ababa, which is heard later in morning, near 9-10:30 a.m.

ITK, 16.385 mc., at Mogadiscio, Italian Somaliland, has been quite active of late, logged at 6 a.m., 7:10 and 7:20 a.m. ITK usually works IAC, always using clear speech.

All the Italian fones QSL through the QRA in Rome often mentioned in these columns.

**ASIATIC REVIEW**

TAIWAN . . . JIB, 10.535 mc., Taihoku, Taiwan (formerly called Formosa), was once logged at 5:45 a.m., using side-band secrecy. JIB generally contacts some Nazaki fone near this time.

BURMA . . . VVS, 12.87 mc., Mingaladon, has been very active, usually working VVN, 13.35 mc., Fort St. George, Madras, India. Heard recently at 6-6:15 a.m. several days. VVN has had the better signal, at times reaching R8, while VVS' best was R6.

JAPAN . . . JVI, 13.56 mc., Nazaki, logged at 6:20 a.m., using inv. speech. JVE, 15.66 mc., also Nazaki, heard at 6:50 a.m. JVO, 10.37 mc., Nazaki, heard daily around 5-7 a.m., in contact with TDE, 10.065 mc., Manchukuo.

*(Continued on page 305)*

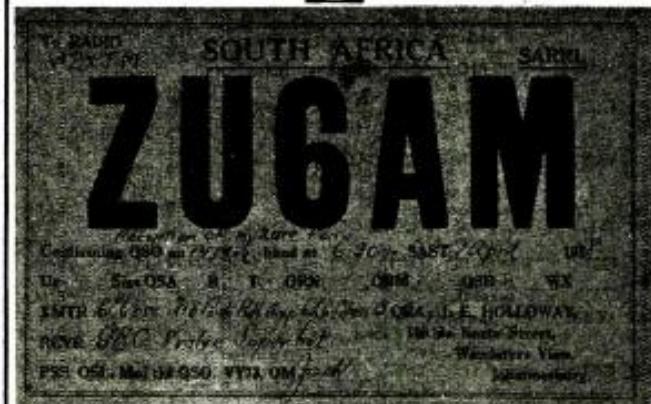
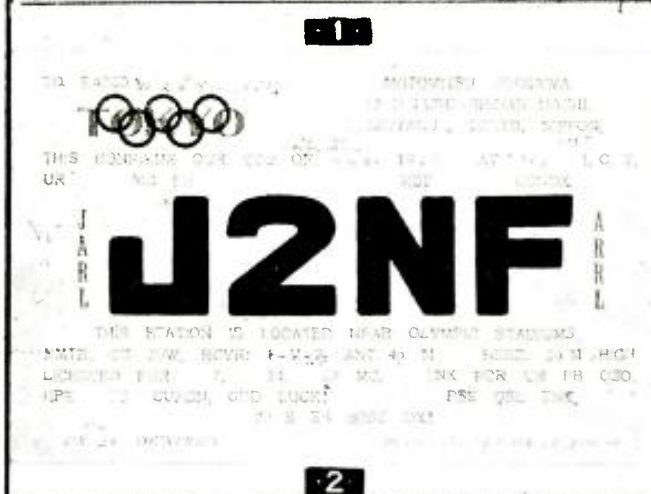
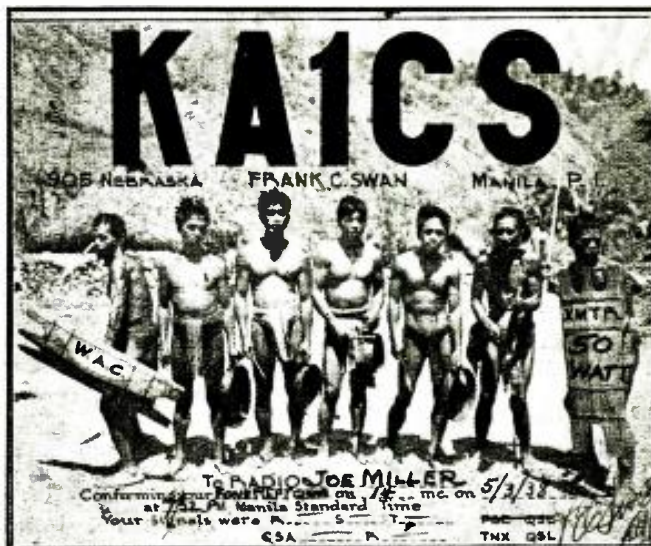

# World Short Wave Stations

*Revised Monthly*

Broadcasters' Calls in bold type  
Phones' in light type

Reports on station changes are appreciated.

Mc.	Call	Mc.	Call	Mc.	Call
31.600	<b>WIXKA</b>	BOSTON, MASS., 9.494 m., Addr. Westinghouse Co. Daily 5 am.-12 m., Sun. 7 am.-12 m. Relays WBZ.	20.700	LSY	BUENOS AIRES, ARG., 14.49 m., Addr. Transradio Internatl. Tests irregularly.
31.600	<b>WIXKB</b>	SPRINGFIELD, MASS., 9.494 m., Addr. Westinghouse Co. Daily 5 am.-12 m., Sun. 7 am.-12 m. Relays WBZ.	20.380	GAA	RUGBY, ENG., 14.72 m. Calls Arg., Brazil mornings.
31.600	<b>W3XEY</b>	BALTIMORE, MD., 9.494 m., Relays WFBZ 4 pm.-12 m.	20.040	OPL	LEOPOLDVILLE, BELGIAN CONGO, 14.97 m. Works ORG morn.
31.600	<b>W2XDY</b>	NEW YORK CITY, 9.494 m., Addr. Col. Broad. System, 485 Madison Ave. Daily 5-10 pm.; Sat. and Sun. 12.30-5, 6-9 pm.	20.020	DHO	NAUEN, GERMANY, 14.99 m., Addr. Reichspostzenstralamt. Works S. Am. mornings.
31.600	<b>W9XHW</b>	MINNEAPOLIS, MINN., 9.494 m. Relays WCCO 9 am.-12 m.	19.900	LSG	BUENOS AIRES, ARG., 15.08 m., Addr. (See 20.700 mc.) Tests irregularly.
31.600	<b>W3XKA</b>	PHILADELPHIA, PA., 9.494 m., Addr. NBC. Relays KYW 9 am.-10 pm.	19.820	WKN	LAWRENCEVILLE, N. J., 15.14 m., Addr. A. T. & T. Co. Calls England daytime.
31.600	<b>W5XAU</b>	OKLAHOMA CITY, 9.494 m., Sun 12 n-1 pm., 6-7 pm. Irregular other times.	19.680	CEC	SANTIAGO, CHILE, 15.24 m., Addr. Cia. Internacional de Radio. Calls Col. and Arg. daytime.
31.600	<b>W4XCA</b>	MEMPHIS, TENN., 9.494 m. Addr. Memphis Commercial Appeal. Relays WMC.	19.650	LSN5	BUENOS AIRES, ARG., 15.27 m., Addr. (See 21.020 mc.) Calls Europe daytime.
31.600	<b>W8XAI</b>	ROCHESTER, N. Y., 9.494 m., Addr. Stromberg Carlson Co. Relays WHAM 7.30-12.05 am.	19.620	VQG4	NAIROBI, KENYA, 15.28 m., Addr. Cable and Wireless, Ltd. Calls London 7-8.30 am.
31.600	<b>W8XWJ</b>	DETROIT, MICH., 9.494 m., Addr. Evening News Ass'n. Relays WWJ 6-12.30 am., Sun. 8 am.-12 m.	19.600	LSF	BUENOS AIRES, ARG., 15.31 m., Addr. (See 20.700 mc.) Tests irregularly.
31.600	<b>W9XPD</b>	ST. LOUIS, MO., 9.494 m., Addr. Pulitzer Pub. Co. Relays KSD.	19.480	GAD	RUGBY, ENG., 15.4 m. Calls VQG4 7.30-8 am.
26.450	<b>W9XA</b>	KANSAS CITY, MO., 11.33 m., Addr. Commercial Radio Eqpt. Co. Testing after August 1st.	19.355	FTM	ST. ASSISE, FRANCE, 15.5 m. Calls S. America mornings.
26.400	<b>W9XAZ</b>	MILWAUKEE, WIS., 11.36 m., Addr. The Journal Co. Relays WTMJ from 1 pm.	19.345	PMA	BANDOENG, JAVA, 15.51 m. Works Holland 5.30-11 am.
26.300	<b>W2XJI</b>	NEW YORK, N. Y., 11.4 m., Addr. Bamberger Broad. Service, 1440 Broadway. Relays WOR 8 am.-1 am.	19.260	PPU	RIO DE JANEIRO, BRAZ., 15.58 m., Addr. Cia. Radiotel. Brasileira. Works France mornings.
26.100	<b>W9XJL</b>	SUPERIOR, WIS., 11.49 m. Relays WEBG daily.	19.220	WKF	LAWRENCEVILLE, N. J., 15.6 m., Addr. A.T.&T. Co. Calls London and Paris daytime.
26.100	<b>GSK</b>	DAVENTRY, ENG., 11.49 m., Addr. B.B.C., London. Operates irregularly.	19.200	ORG	RUYSSELEDE, BELGIUM, 15.62 m. Calls OPL mornings.
25.950	<b>W6XKG</b>	LOS ANGELES, CAL., 11.56 m., Addr. B. S. McGlashan, Wash. Blvd. at Oak St. Relays KGFJ 24 hours daily.	19.160	GAP	RUGBY, ENG., 15.66 m. Calls Australia 1-8 am.
25.950	<b>W9XUP</b>	ST. PAUL, MINNESOTA, 11.56 m. Relays KSTP.	19.020	HS8PJ	BANGKOK, SIAM, 15.77 m. Mondays 8-10 am.
21.550	<b>GST</b>	DAVENTRY, ENG., 13.92 m., Addr. (See 26.100 mc.) Irregular at present.	18.970	GAQ	RUGBY, ENG., 15.81 m. Calls S. Africa mornings.
21.540	<b>W8XK</b>	PITTSBURGH, PA., 13.93 m., Addr. Grant Bldg. Relays KDKA 6.45-9 am. Exc. Sun.	18.890	ZSS	KLIPHEUVEL, S. AFRICA, 15.88 m., Addr. Overseas Comm. of S. Africa, Ltd. Calls GAU 6.30-7 am.
21.530	<b>GSJ</b>	DAVENTRY, ENG., 13.93 m., Addr. (See 26.100 mc.) 5.45 am.-12 n.	18.830	PLE	BANDOENG, JAVA, 15.93 m. Calls Holland 6-11 am.
21.520	<b>W2XE</b>	NEW YORK CITY, 13.94 m., Addr. Col. Broad. Syst., 485 Madison Ave. Daily exc. Sat. and Sun. 6.30-9 am. Sat. and Sun. 7 am.-12 n.	18.680	OCI	LIMA, PERU, 16.06 m. Tests with Bogota, Col.
21.500	<b>W2XAD</b>	SCHENECTADY, N. Y., 13.95 m., General Electric Co., 7-11 am.	18.620	GAU	RUGBY, ENG., 16.11 m. Calls N. Y. daytime. Calls ZSS 6.30-7 am.
21.470	<b>GSH</b>	DAVENTRY, ENG., 13.97 m. (See 26.100 mc.) 5.45 am.-12 n.	18.480	HBH	GENEVA, SWITZERLAND, 16.26 m., Addr. Radio Nations. Sun., 10.45-11.30 am.
21.450	<b>DJS</b>	BERLIN, GERMANY, 13.99 m., Addr., Broadcasting House. 12.05-11 am.	18.345	FZS	SAIGON, INDO-CHINA, 16.35 m. Works Paris early morning.
21.420	<b>WKK</b>	LAWRENCEVILLE, N. J., 14.01 m., Addr. Amer. Tel. & Tel. Co. Calls S. Amer. 7 am.-7 pm.	18.340	WLA	LAWRENCEVILLE, N. J., 16.36 m., Addr. A.T.&T. Co. Calls England daytime.
21.080	<b>PSA</b>	RIO DE JANEIRO, BRAZ., 14.23 m., Calls WKK daytime.	18.310	GAS	RUGBY, ENG., 16.38 m. Calls N.Y. daytime.
21.060	<b>WKA</b>	LAWRENCEVILLE, N. J., 14.25 m. Addr. (See 21.420 mc.) Calls England morning and afternoon.	18.299	YVR	MARACAY, VENEZ., 16.39 m. Works Germany mornings.
21.020	<b>LSN6</b>	BUENOS AIRES, ARG., 14.27 m., Addr. Cia. Internacional de Radio. Works N.Y.C. 7 am.-7 pm.	18.250	FTO	STE. ASSISE, FRANCE, 16.43 m. Works S. America daytime.
20.860	<b>EHY-EDM</b>	MADRID, SPAIN, 14.38 m., Addr. Cia. Tel. Nacional de Espana. Works S. Amer. mornings.	18.200	GAW	RUGBY, ENG., 16.48 m. Works N.Y.C. daytime.
			18.135	PMC	BANDOENG, JAVA, 16.54 m. Works Holland mornings.
			18.115	LSY3	BUENOS AIRES, ARG., 16.56 m., Addr. (See 20.700 mc.) Tests irregularly. Broadcasts 5-6 pm. Friday.
			18.040	GAB	RUGBY, ENG., 16.83 m. Works Canada morning and afternoon.
			17.810	PCV	KOOTWIJK, HOLLAND, 16.84 m. Works Java 6-8 am.

## 16 Met. Broadcast Band

Mc.	Call	Mc.	Call
17.810	—	ROME, ITALY, 16.84 m., Addr. (See 2RO, 11.81 mc.) Relays 2RO to 6 pm. irregularly.	
17.810	TP83	PARIS, FRANCE, 16.84 m. Addr. (See 15.245 mc.) 8.30-10 am.	
17.800	TGWA	GUATEMALA CITY, GUAT., 16.84 m., Addr. Ministre De Fomento. Irregular.	
17.790	GSG	DAVENTRY, ENG., 16.86 m., Addr. B.B.C., London. 1 m-3.15 am., 5.45 am.-12 n., 12.20-6, 6.17-8.30 pm.	
17.785	JZL	TOKYO, JAPAN, 16.87 m. 6-6.30 pm. 12.30-1.30 am.	
17.780	W3XAL	BOUND BROOK, N. J., 16.87 m., Addr. Natl. Broad. Co. 8 am.-8 pm.	
17.770	PHI2	HUIZEN, HOLLAND, 16.88 m., Addr. (See PHI, 11.730 mc.) Daily except Wednesday, 7.25-9.30 am., Sun. 6.25-9.30 am.	
17.760	DJE	BERLIN, GERMANY, 16.89 m., Addr. Broadcasting House. 12.05-10 am.; also Sun. 11.10 am.-12.25 pm.	
17.760	W2XE	NEW YORK, N. Y., 16.89 m., Addr. Col. Broad. System, 485 Madison Ave. Irregular.	
17.755	ZBWS	HONGKONG, CHINA, 16.9 m., Addr. P.O. Box 200. 4-10 am. Irregular.	

## End of Broadcast Band

17.741	HSP	BANGKOK, SIAM, 16.91 m. Works Germany 6-7 am., 8-9 pm. Works JVE 11 pm.-6 am.
17.650	XGM	SHANGHAI, CHINA, 17 m. Works London 7-9 am.
17.520	DFB	NAUEN, GERMANY, 17.12 m. Works S. America, near 9.15 am. Works Siam 6-7 am., 8-9 pm.
17.480	VWY2	KIRKEE, INDIA, 17.16 m. Works London 7.30-8.30 am.
17.310	W2XGB	HICKSVILLE, L. I., N. Y., 17.33 m., Addr. Press Wireless, Box 296. Tests 9.30-11.30 am. except Sat. and Sun.
17.280	FZE8	DJIBOUTI, FR. SOMALILAND, AFR. 17.36 m., Phones Paris near 8 am. Tests 1st Thurs. in the month, 8-8.30 am.
17.120	WAQ	OCEAN GATE, N. J., 17.52 m., Addr. A.T.&T. Co. Works ships irregularly.
17.080	GBC	RUGBY, ENG., 17.56 m. Works ships irregularly.
16.835	ITK	MOGADISCIO, ITAL. SOMALILAND, 18.32 m. Calls IAC around 9.30 am.
16.270	WLK	LAWRENCEVILLE, N. J., 18.44 m., Addr. A.T.&T. Co. Works S. Amer. daytime.
16.270	WOG	OCEAN GATE, N. J., 18.44 m., Addr. A.T.&T. Co. Works England late afternoon.
16.240	KTO	MANILA, P. I., 18.47 m., Addr. RCA Comm. Works Japan and U. S. 5-9 pm. and early am. irreg.
16.233	FZR3	SAIGON, INDO-CHINA, 18.48 m. Calls FTK 6-9 am.
		KAHUKU, HAWAII, 18.71 m., Addr. RCA Comm. Works Dixon 3-10 pm.
15.880	FTK	ST. ASSISE, FRANCE, 18.9 m. Works Saigon 6-9 am.
15.865	CEC	SANTIAGO, CHILE, 18.91 m. Calls Peru daytime irregular.
15.810	LSL	BUENOS AIRES, ARG., 18.98 m., Addr. (See 21.020 mc.) Works London mornings and Paris afternoons.
15.660	JVE	NAZAKI, JAPAN, 19.16 m. Works Java and Siam early am.

(Continued on page 280)

All Schedules Eastern Standard Time



# Third Silver Trophy Awarded To

*Alvin Abrams*  
W2DTT, New York

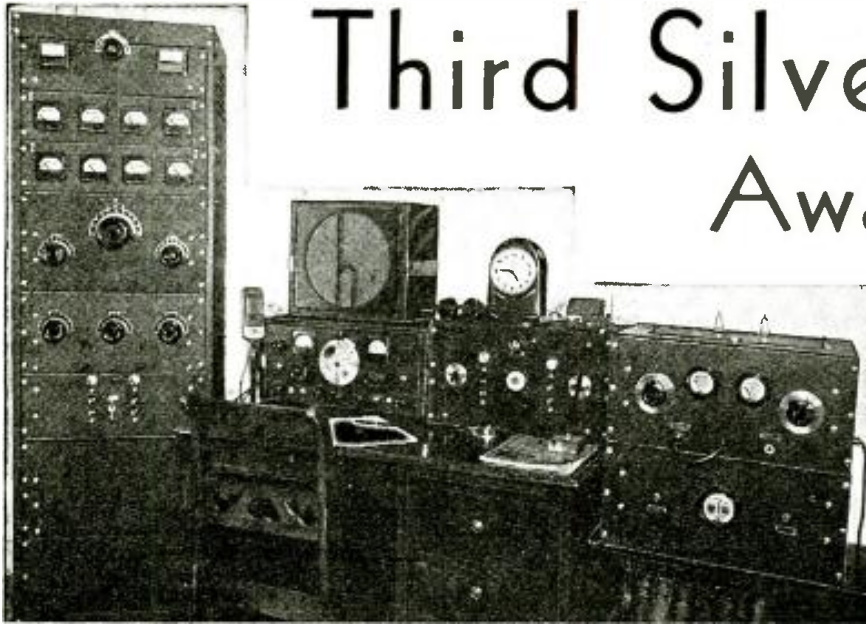

Above—Crackerjack "ham station" owned and operated by Alvin Abrams, W2DTT, New York City. To say the least, great credit must be given Mr. Abrams for the very neat workmanship exemplified in the construction of the transmitter and the other apparatus. The receiver is a Hallicrafter model SX17.

Alvin Abrams, W2DTT, owner and operator of the "ham station" shown in the photo above. Mr. Abrams' motto is — "If it's worth building at all, it's worth building well."



Trophy  
Awarded  
for best  
HAM  
STATION  
Photo  
of the Month

Mr. Abrams, a progressive New York radio amateur, has a snappy station.

● HEREWITH photos of my "ham station" located in New York City. This station has been licensed and in operation since 1932. Some time ago I decided that a new and larger transmitter should be built and the photo shows the results of this plan. The apparatus shown, exclusive of the Hallicrafter receiver, is home-made, and quite a lot of time was spent in assembling the parts so that they would have that "commercial" appearance. The finish has a lot to do with the final appearance of the transmitter and other apparatus, but nowadays it is relatively easy to obtain a good finish, as panels are available with a factory lacquer on them.

The transmitter at the left of the photo is a "rack and panel" job; it includes apparatus for 20 to 160 meter phone and a c.w. job rated at 500 watts input on code, and 400 watts input on phone.

Altogether, the transmitter has six chassis. The bottom one contains the final amplifier power-supply and relays, while

the second one holds the audio driver, modulator and driver power-supply. The exciter and modulator power-supplies and start-stop controls are built on the third chassis. The exciter unit is on the fourth and the final amplifier on the fifth deck. The antenna tuning unit is the sixth or uppermost.

The pre-amplifier and monitor are built into a separate cabinet and this is shown on the right-hand side of the desk.

The audio equipment consists of a Velotron microphone coupled to a 6U7 pentode, a 6N7 phase inverter and a pair of 6C5 triodes in push-pull, terminating in a 500 ohm line. This line connects to a pair of 6A3's which drive the Amperex ZB-120 zero-bias modulators.

The exciter uses a 6F6 pentode oscillator, capacitively coupled to a 6L6 amplifier, doubler or quadrupler, capacitively coupled to a pair of 807's in parallel.

(Continued on page 315)



This beautiful silver trophy stands 11 3/4" high and is to be awarded monthly by SHORT WAVE & TELEVISION magazine for the best photo of a Ham station. The silver statue stands on a handsome bakelite base on which is a silver plate. The name of the winner will be engraved on this plate before the trophy is sent to him. See rules on page 315.

Mc.	Call	
15.620	JVF	NAZAKI, JAPAN, 19.2 m. Works Cal. near 5 am. and 8 pm.
15.550	CO9XX	TUINICU, ORIENTE, CUBA, 19.29 m., Addr. Frank Jones, Central Tuinicu, Tuinicu, Santa Clara. Broadcasts irregularly evenings.
15.450	IUG	ADDIS ABABA, ETHIOPIA, 19.44 m. Works Rome 9-10.30 am.
15.415	KWC	DIXON, CAL., 19.46 m., Addr. A. T. & T. Co. Works Hawaii 2-7 pm.
15.370	HAS3	BUDAPEST, HUNGARY, 19.52 m., Addr. Radiolabor. Gyalii Ut 22. Sun. 9-10 am.
15.360	DZG	ZEESEN, GERMANY, 19.53 m., Addr. Reichspostzenstralamt. Tests irregularly.
15.355	KWU	DIXON, CALIF., 19.53 m., Addr. A.T.&T. Co. Phones Pacific Isles and Japan.

### 19 Met. Broadcast Band

15.340	DJR	BERLIN, GERMANY, 19.56 m., Addr. Br'dcast'g House, 8-9 am., 4.50-10.45 pm.
15.330	W2XAD	SCHENECTADY, N. Y., 19.56 m., Addr. General Electric Co. Relays WGY 11.30 am.-6 pm.
15.320	OLR5B	PRAGUE, CZECHOSLOVAKIA, 19.58 m. Addr. (See 11.840 mc.) Sun., Wed., Sat. 5-5.10 pm.; Mon., Tues., Thurs., Fri. 6.55-9.55 pm.; Sun. 5.55-8.55 pm.
15.310	GSP	DAVENTRY, ENG., 19.6 m., Addr. (See 26.100 mc.) 12.17-1.15, 4.15-6, 6.17-8.30 pm.
15.300	XEBM	MAZATLAN, SIN., MEX., 19.61 m., Addr. Box 78, "El Pregonero del Pacifico." Irregularly 9-10 am., 1-2, 8-10 pm.
15.300	—	ROME, ITALY, 19.61 m., Addr. (See 2RO, 11.81 mc.) Relays 2RO to 9 pm. irregularly.
15.290	LRU	BUENOS AIRES, ARG., 19.62 m., Addr. El Mundo. Relays LRI, 7-9 am.
15.280	H13X	CIUDAD TRUJILLO, D. R., 19.63 m. Relays H1X Sun. 7.40-10.40 am. Weekdays 12.10-1.10 pm.
15.280	DJQ	BERLIN, GERMANY, 19.63 m., Addr. Broadcasting House, 12.05-10 am., 4.50-10.45 pm. Also Sun. 11.10 am.-12.25 pm.
15.270	W2XE	NEW YORK CITY, 19.65 m., Addr. (See 21.520 mc.) Daily except Sat. and Sun., 12 n-5 pm., Sat. & Sun. 1.30-5 pm.
15.260	GS1	DAVENTRY, ENG., 19.66 m., Addr. See 26.100 mc.) 12.17-4, 9.17-11.20 pm.
15.252	RIM	TASHKENT, U.S.S.R., 19.67 m. Works RKL near 7 am.
15.250	W1XAL	BOSTON, MASS., 19.67 m., Addr. University Club. Daily 1-2 pm., Sun. 10 am.-12 n. Tues., Thurs. 3.30-5.30 pm.
15.245	TPA2	PARIS, FRANCE, 19.68 m., Addr. 98 Bis. Blvd. Haussmann. "Paris Mondial" 5-10 am.
15.230	HS8PJ	BANGKOK, SIAM, 19.7 m. Irregularly Mon. 8-10 am.
15.230	OLR5A	PRAGUE, CZECHOSLOVAKIA, 19.7 m. Addr. (See OLR4A, 11.84) Sun., Wed., Sat. 5-5.10 pm.; Mon., Tues., Thurs., Fri. 6.55-9.55 pm.; Sun 5.55-8.55 pm.
15.220	PCJ2	HUIZEN, HOLLAND, 19.71 m., Addr. N. V. Philips' Radio Hilversum. Tues. 12.30-2 am., Wed. 9.30-11.30 am.
15.210	W8XK	PITTSBURGH, PA., 19.72 m., Addr. (See 21.540 mc.) 9 am.-7 pm.
15.200	DJ8	BERLIN, GERMANY, 19.74 m., Addr. (See 15.280 mc.) 12.05-11 am., 4.50-10.45 pm. Also Sun. 11.10 am.-12.15 pm.
15.190	LYZ4	LAHTI, FINLAND, 19.75 m. Addr. Oy Suomen Yleisradio, Ab., Lahlen Yleisradioasema, Lahti. Irregular 12.30-1.30 pm.
15.190	ZBW4	HONGKONG, CHINA, 19.75 m., Addr. P. O. Box 200. Irregular. 11.30 pm. to 1.15 am., 3-10 am.
15.180	GSO	DAVENTRY, ENG., 19.76 m., Addr. (See 26.100 mc.) 1-3.15 am., 4.15-6, 6.17-9 pm.
15.170	TGWA	GUATEMALA CITY, GUAT., 19.77 m., Addr. (See 17.8 mc.) Daily 10.45-11 am.; Sun. 10.45 am.-6 pm.
15.160	XEW7	MEXICO CITY, MEXICO, 19.79 m., 12 n.-12 m., irregular.

Mc.	Call	
15.160	JZK	TOKYO, JAPAN, 19.79 m. 12.30-1.30 am., 2.30-4, 4.30-5.30, 6-6.30 pm.
15.160	VUD3	DELHI, INDIA, 19.79 m., Addr. All India Radio. 1.30-3.30 am., 8.30-10.30 pm.
15.155	SM5SX	STOCKHOLM, SWEDEN, 19.79 m., Daily 11 am.-5 pm., Sun. 9 am.-5 pm.
15.150	YDC	BANDOENG, JAVA, 19.8 m., Addr. N. I. R. O. M. 6-7.30 pm., 10.30 pm.-2 am., Sat. 7.30 pm.-2 am., daily 5.30-10.30 am.
15.140	GSF	DAVENTRY, ENG., 19.82 m., Addr. (See 26.100 mc.) 1-3.15, 5.45 am.-12 n., 4.15-6, 6.20-8.30 pm.
15.130	TPB6	PARIS, FRANCE, 19.83 m., Addr. "Paris Mondial," 98 Bis Blvd. Haussmann. 6-8.15 pm.
15.130	W1XAL	BOSTON, MASS., 19.83 m., Addr. World-Wide B'cast'g Foundation. University Club. 10-11 am., Mon.-Fri.
15.120	HVJ	VATICAN CITY, 19.83 m., 10.30-10.45 am., except Sun., Sat. 10-10.45 am.
15.110	DJL	BERLIN, GERMANY, 19.85 m., Addr. (See 15.280 mc.) 12 m.-2. 8-9 am., 10.40 am. to 4.30 pm. Sun. also 6-8 am.
15.080	RKI	MOSCOW, U.S.S.R., 19.87 m. Works Tashkent near 7 am. Broadcasts Sun. 12.15-2.30 pm. Daily 7-9.15 pm.

### End of Broadcast Band

15.055	WNC	HIALEAH, FLORIDA, 19.92 m., Addr. A.T.&T. Co. Calls Central America daytime.
14.980	KAY	MANILA, P. I., 20.03 m., Addr. RCA Comm. Works Pacific Is. Mornings.
14.960	PSF	RIO DE JANEIRO, BRAZIL, 20.05 m., Works with Buenos Aires daytime.
14.950	HJB	BOGOTA, COL., 20.07 m. Calls WNC daytime.
14.940	PSE	RIO DE JANEIRO, BRAZIL, 20.08 m., Broadcasts Wed. 3.45-4.15 pm.
14.940	H11	CIUDAD TRUJILLO, D. R., 20.08 m. Phones WNC daytime.
14.940	HJA3	BARRANQUILLA, COL., 20.08 m. Works WNC daytime.
14.920	LZA	SOFIA, BULGARIA, 20.10 m., Addr. Radio Gerata. Mon. Tues., Thurs., Fri. 11.30 am.-2.45 pm., Wed. 11.30 am.-4.45 pm., Sat. 11.30 am.-5 pm., Sun. 2 am.-5 pm. Daily except Sun. 5-6.30 am.
14.845	OCJ2	LIMA, PERU, 20.21 m. Works South America stations daytime.
14.790	ROU	OMSK, SIBERIA, U.S.S.R., 20.28 m. Works Moscow irregularly 7-9 am.
14.730	IQA	ROME, ITALY, 20.37 m. Irregular.
14.653	GBL	RUGBY, ENGLAND, 20.47 m. Works JVH 1-7 am.
14.640	TYF	PARIS, FRANCE, 20.49 m. Works Saigon and Cairo 3-7 am, 12 n.-2.30 pm.
14.600	JVH	NAZAKI, JAPAN, 20.55 m. Broadcasts irregularly 5.11.30 pm. Works Europe 4-8 am.
14.590	WMN	LAWRENCEVILLE, N. J., 20.56 m., Addr. A.T.&T. Co. Works England morning and afternoon.
14.535	HBJ	GENEVA, SWITZERLAND, 20.64 m., Addr. Radio Nations. Broadcasts Sun. 1.45-2.30 pm., Mon. 1.30-1.45 am.
14.530	LSN	BUENOS AIRES, ARG., 20.65 m. Addr. (See 20.020 mc.) Works N. Y. C. afternoons.
14.500	LSM2	BUENOS AIRES, ARG., 20.69 m., Addr. (See 21.020 mc.) Works Rio and Europe daytime.
14.485	TIR	CARTAGO, COSTA RICA, 20.71 m. Works Central America and U. S. A. daytime.
14.485	YSL	SAN SALVADOR, SALVADOR, 20.71 m. Irregular.
14.485	HPF	PANAMA CITY, PANAMA, 20.71 m. Works WNC daytime.
14.485	TGF	GUATEMALA CITY, GUATEMALA, 20.71 m. Works WNC daytime.
14.485	YNA	MANAGUA, NICARAGUA, 20.71 m. Works WNC daytime.
14.485	HRL5	NACAOME, HONDURAS, 20.71 m. Works WNC daytime.
14.485	HRF	TEGUCIGALPA, HONDURAS, 20.71 m. Works WNC daytime.

Mc.	Call	
14.480	IBS	ROME, ITALY, 20.7 m. Works Eritrea and Addis Ababa 6.30-7.30 am.
14.470	WMF	LAWRENCEVILLE, N. J., 20.73 m., Addr. A.T.&T. Co. Works London and Paris daytime.
14.460	DZH	ZEESEN, GERMANY, 20.75 m., Addr. (See 15.360 mc.) Irregular.
14.440	—	RADIO MALAGA, SPAIN, 20.78 m. Relays Salamanca 8.15-8.45 pm. Sometimes 2-4 pm.
14.440	GBW	RUGBY, ENG., 20.78 m. Works U.S.A. afternoons.
14.166	PIIJ	DORDRECHT, HOLLAND, 21.15 m., Addr. (See 7.088 mc.) Sat. 12 n.-12.30 pm.
14.004	EA9AH	TETUAN, SPANISH MOROCCO, 21.4 m. Apartado 124. News at 4.30 and 7.15 pm. Relays Salamanca from 5.40 pm.
13.990	GBA	RUGBY, ENG., 21.44 m. Works Buenos Aires late afternoon.
13.820	SUZ	ABOU ZABAL, EGYPT, 21.71 m. Works with Europe 11 am.-2 pm. Works GBB daily at 11 am.
13.690	KKZ	BOLINAS, CALIF., 21.91 m., Addr. RCA Comm. Irregularly.
13.635	SPW	WARSAW, POLAND, 22 m. Daily 6-8 pm. Sat. & Sun. 6-9 pm.
13.630	ZGB	KUALA LUMPUR, F.M.S. 22 m. Works Java, VVS, VVN and Siam, 6.30-8 am.
13.585	GBB	RUGBY, ENG., 22.08 m. Works Canada afternoons. Works SUZ at 11 am.
13.415	GCJ	RUGBY, ENG., 22.36 m. Works Japan and China early morning.
13.410	YSJ	SAN SALVADOR, SALVADOR, 22.37 m. Works WNC daytime.
13.390	WMA	LAWRENCEVILLE, N. J., 22.4 m., Addr. A.T.&T. Co. Works England morning and afternoon.
13.380	IDU	ASMARA, ERITREA, AFRICA, 22.42 m. Works Rome daytime.
13.350	VVN	FT. ST. GEORGE, MADRAS, INDIA, 22.46 m. Works VVS, Burma, near 7 am.
13.345	YVQ	MARACAY, VENEZUELA, 22.48 m. Works WNC daytime.
13.285	CGA3	DRUMMONDVILLE, QUE., CAN., 22.58 m. Works London and ships afternoons.
13.330	IRJ	ROME, ITALY, 22.69 m. Works Tokyo 5-9 am., irregularly.
12.870	VVS	MINGALADON, BURMA, 23.30 m. Works ZGB, VVN, and Siam, 6.30-7.30 am.
12.862	W9XDH	ELGIN, ILL., 23.32 m. Press Wireless, Tests 2-5 pm.
12.840	WAQ	OCEAN GATE, N. J., 23.36 m., Addr. A.T.&T. Co. Works with ships irregularly.
12.830	CNR	RABAT, MOROCCO, 23.38 m., Addr. Director General Tele. & Teleg. Stations. Works TYA, Paris 6-7 am., 2.30-4 pm.
12.800	IAC	PISA, ITALY, 23.45 m. Works Italian ships mornings.
12.780	GBC	RUGBY, ENG., 23.47. Works ships irregularly.
12.325	DAF	NORDEICH, GERMANY, 24.34 m. Works German ships daytime.
12.290	GBU	RUGBY, ENG., 24.41 m. Works N. Y. C. evenings.
12.250	TYB	PARIS, FRANCE, 24.49 m. Irregular.
12.235	TFJ	REYKJAVIK, ICELAND, 24.52 m. Works Europe mornings. Broadcasts Sun. 1.40-2.30 pm.
12.215	TYA	PARIS, FRANCE, 24.56 m. Works French ships in morning and afternoon.
12.200	—	TRUJILLO, PERU, 24.58 m., "Rancho Grande." Address Hacienda Chiclin. Irregular.
12.150	GBS	RUGBY, ENG., 24.69 m. Works N. Y. C. evenings.
12.130	DZE	ZEESEN, GERMANY, 24.73 m., Addr. (See 15.360 mc.) Tests irregular.
12.120	TPZ	ALGERS, ALGIERS, 24.75 m. Calls Paris near 6 am., and 2.30-4 pm.
12.060	PDV	KOOTWIJK, HOLLAND, 24.88 m. Tests irregularly.
12.060	RNE	MOSCOW, U.S.S.R., 24.88 m. Daily 6-7 am., 12.15-1 pm., 8-9.15, 10-11 pm., also Sun. 6 am.-1 pm.
11.991	FZ54	SAIGON, INDO-CHINA, 25.02 m. Phones Paris irregular.

(Continued on page 282)

All Schedules Eastern Standard Time



# DX Receiving Aerials

● UNDOUBTEDLY one of the most important aspects of radio as a hobby is to be found in the widespread appeal of short-wave listening and dxing. With the number of powerful short-wave broadcasting stations always increasing, dxing has become a real art. Today the average swl is usually possessed of highly efficient receiving equipment; but, in many cases, the results obtained are scarcely as good as could reasonably be expected, largely because of the fact that very little thought is given to the problem of erecting a really efficient receiving aerial.

Assuming that no further improvement can be made in the receiver itself, the dx fan should turn his attention to the choice of a good aerial. At once he is faced with a difficulty, which arises from the fact that there is *no best all-wave aerial*; since any length of free wire in space acts as an interceptor of radio frequency energy at one fundamental frequency and the harmonics of that frequency.

Secondly, it must be remembered that every aerial is possessed of *directional* qualities. Actually, the *vertical* aerial is the *least* directional of all; and, under ordinary circumstances, when absolutely in the clear, it is *omni-directional*, that is, it will receive signals equally well from all directions.

However, it is usually impossible to erect any aerial absolutely in the open, and therefore even vertical aerials do become possessed of definite directional qualities. As the average swl is unable to measure the directional qualities of an aerial, it is better for him to construct one in accordance with theory, and trust that it will function as desired.

## Simple Half-Wave Doublet

The simplest of all aerials is the single half-wave doublet, as shown in diagram 1. This should have a length equal to one-half

The principal types of effective "DX" aerials for short wave reception are illustrated at the right. The "V" type aerials present new possibilities for "DX" hounds; two or more, facing in different directions, could be arranged with a switch to cut in the desired one.

the wavelength in metres of the band on which reception is most desired. Of course, signals on wavelengths greatly removed from the resonant frequency of this aerial will be received; but it will only function really well at or near its natural wavelength.

As regards its directional qualities, the single half-wave doublet is directional *broad-side*—i.e., at right angles to the axis of the wire. Accordingly it should be situated with this fact in mind—with its broad-side facing the more-difficult-to-log stations.

## Improving the Half-Wave Doublet

The half-wave doublet may be greatly improved by altering its length and/or by varying the method of connecting the lead-in.

The *Johnson Q* is an example of this, having two quarter-wave halves with a quarter-wave matching stub (see diagram 2).

The *Johnson Q* operates only on the frequency for which it is designed; and care must be taken to ensure that the quarter-wave sections are exactly the required length. A convenient formula for calculating the length of any half-wave aerial is—

$$L = M \times 1.56$$

Where L equals Length in feet and M equals wavelength in metres.

Wavelength (Metres)	Johnson Q Data	
	1/4-wave Feeder Section.	1/2-wave Aerial (in 2 1/4-wave halves)
10 m. Amateur band .....	8 ft.	16 ft. 1 1/2 in.
20 m. Amateur band .....	16 ft. 5 in.	32 ft. 11 in.
40 m. Amateur band .....	32 ft. 9 in.	65 ft. 4 in.
19 m. B/C band .....	15 ft. 4 in.	30 ft. 7 in.

(Continued on page 300)

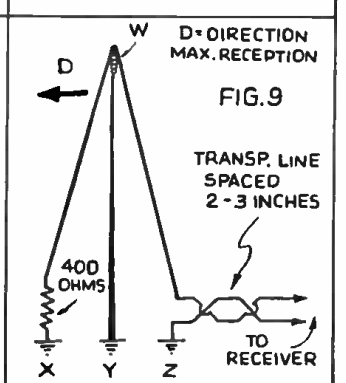
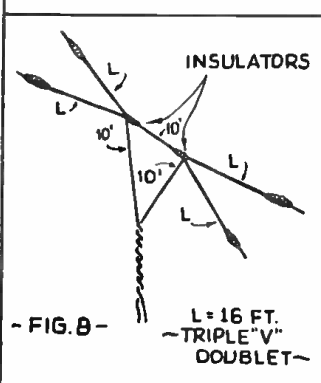
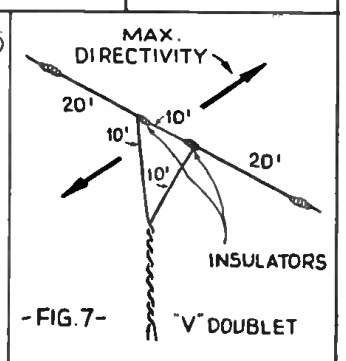
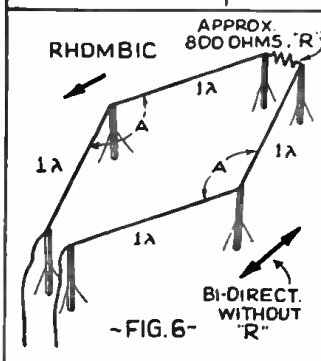
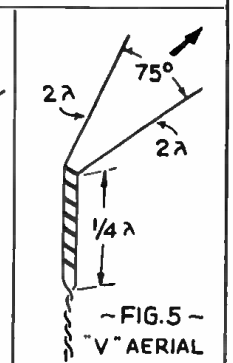
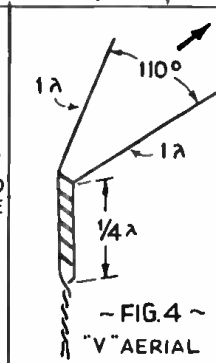
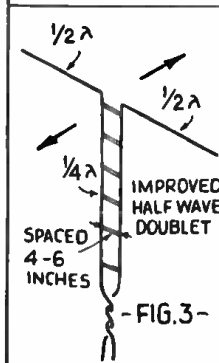
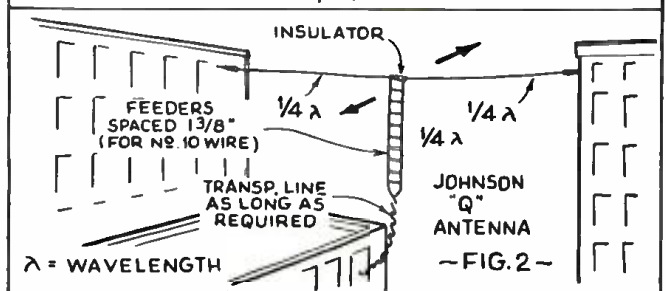
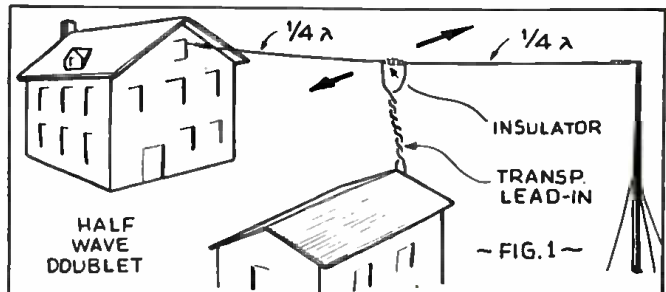

Mc.	Call		Mc.	Call		Mc.	Call	
11.970	H12X	CIUDAD TRUJILLO, D. R., 25.07 m., Addr. La Voz de Hispaniola. Relays HIX Tue. and Fri. 8.10-10.10 pm.	11.740	COCX	HAVANA, CUBA, 25.55 m. P. O. Box 32. 6.55 am.-1 am. Sun. till 12 m. Relays CMX.	10.550	WOK	LAWRENCEVILLE, N. J., 28.44 m., Addr. A.T.&T. Co. Works S. A. nights.
11.955	IUC	ADDIS ABABA, ETHIOPIA, 25.09 m. Works IAC around 12 m.	11.740	HVJ	VATICAN CITY, 25.55 m. Testing irregular.	10.535	JIB	TAIHOKU, TAIWAN, 28.48 m. Works Japan around 6.25 am. Broadcasts, relaying JFAK 9.05-10 am., 1-2.30 am. Sun. to 10.15 am.
11.950	KKQ	BOLINAS, CALIF., 25.1 m. Tests irregularly evenings.	11.730	XETA	MONTEREY, MEX. 25.57 m., Addr. Box 203. Relays XET, 12 n.-2 pm.	10.520	VLK	SYDNEY, AUSTRALIA, 28.51 m., Addr. Amalgamated Wireless of Australasia Ltd. Works England 1-6 am.
11.940	FTA	STE. ASSISE, FRANCE, 25.13 m. Works Morocco mornings and Argentina late afternoon.	11.730	PHI	HUIZEN, HOLLAND, 25.57 m., Addr. N. V. Philips' Radio.	10.430	YBG	MEDAN, SUMATRA, 28.76 m. Calls Java 5.30-6.30 am.
<b>25 Met. Broadcast Band</b>			11.720	CJRX	WINNIPEG, CANADA, 25.6 m., Addr. James Richardson & Sons. Ltd. Daily 6 pm.-12 m., Sun. 5-10 pm.	10.410	PKD	KOOTWIJK, HOLLAND, 28.8 m. Works Java 7.30-9.40 am.
11.910	CD1190	VALDIVIA, CHILE, 25.2 m., P. O. Box 642. Relays C869 10 am.-1 pm., 11 am.-10 pm.	11.718	CR78H	LAURENÇO MARQUES, PORTUGUESE E. AFRICA, 25.6 m. Daily 12.05-1, 4.30-6.30, 9.30-11 am., 12.05-4 pm., Sun. 5-7 am., 10 am.-2 pm.	10.410	KES	BOLINAS, CALIF., 28.8 m., Addr. RCA Communications. Irregular.
11.900	XEWI	MEXICO CITY, MEXICO, 25.21 m., Addr. P. O. Box 2874. Mon., Wed., Fri. 3-4 pm., 9 pm.-12 m. Tues. and Thur. 7.30 pm.-12 m., Sat. 9 pm.-12 m.	11.715	TPA4	PARIS, FRANCE, 25.61 m., (See 15.245 mc.) 6-8.15 pm., 8.30-11 pm.	10.370	JVO	NAZAKI, JAPAN, 28.93 m. Works TDE 3-8 am.
11.895	HP51	AGUADULCE, PANAMA, 25.22 m. Addr. La Voz del Interior. 7.30-9.30 pm.	11.710	S8P	MOTALA, SWEDEN, 25.63 m., 1.20-2.05, 6-9 am., 11 am.-1 pm., Sat. 1.20-2 am., 6 am.-1.30 pm., Sun. 3 am.-1.30 pm.	10.370	EAJ43	TENERIFFE, CANARY ISLANDS, 28.93 m. Relays Salamanca, Spain, 2-4, 5-9.45 pm.
11.885	TPA3	PARIS, FRANCE, 25.24 m., Addr. (See 15.245 mc.) 1-4 am., 10.15 am.-5 pm.	11.710	YSM	SAN SALVADOR, EL SALVADOR, 25.63 m., Addr. (See 7.894 mc.) Irregular 1.30-2.30 pm.	10.350	LSX	BUENOS AIRES, ARG., 28.98 m., Addr. Transradio International. Tests irregularly.
11.885	TP87	PARIS, FRANCE, 25.24 m. (See 15.245 mc.) 8.30-11 pm.	11.700	HP5A	PANAMA CITY, PAN., 25.65 m. Addr. Radio Teatro, Apartado 954. 10 am.-10 pm.	10.330	ORK	RUYSSELEDE, BELGIUM, 29.04 m. Broadcasts 1.30-3 pm. Works OPM 1-3 am., 3-5 pm.
11.870	WBXK	PITTSBURGH, PA., 25.26 m., Addr. (See 21.540 mc.) 7-11 pm.	11.700	CB1170	SANTIAGO, CHILE, 25.65 m. Addr. P.O. Box 706. Relays C889 6 pm.-12 m.	10.300	LSL2	BUENOS AIRES, ARG., 29.13 m., Addr. Cia. Internacional de Radio. Works Europe evenings.
11.860	YDB	SOERABAJA, JAVA, 25.29 m., Addr. N. I. R. O. M. Sat. 7.30 pm. to 2.30 am., daily 10.30 pm. to 2 am.	<b>End of Broadcast Band</b>			10.290	DZC	ZEESEN, GERMANY, 29.16 m., Addr. (See 15.360 mc.) Irregular.
11.860	GSE	DAVENTRY, ENG., 25.29 m., Addr. (See 26.100 mc.) Irregular.	11.690	—	SAIGON, INDO-CHINA, 25.66 m., Addr. Radio Boy-Landry, 17 Place A. Foray. 11 pm.-1 am., 5.30-9.15 am.	10.260	PMN	BANDOENG, JAVA, 29.24 m. Relays YDB 5.30-10.30 or 11 am., Sat to 11.30 am.
11.855	DJP	BERLIN, GERMANY, 25.31 m., Addr. (See 15.280 mc.) Irregular 11.35 am.-4, 7-10.45 pm.	11.680	KIO	KAHUKU, HAWAII, 25.68 m., Addr. RCA Comm. Irregularly.	10.250	LSK3	BUENOS AIRES, ARG., 29.27 m., Addr. (See 10.310 mc.) Works Europe and U.S.A. afternoons and evenings.
11.840	KZRM	MANILA, P. I., 25.35 m. Addr. Erlanger & Gallinger, Box 283. 9 pm.-10 am. Irregular.	11.595	VRR4	STONY HILL, JAMAICA, B. W. I., 25.87 m. Works WNC daytime.	10.230	CED	ANTOFAGASTAN, CHILE, 29.33 m. Tests 7-9.30 pm.
11.840	CSW	LISBON, PORT., 25.35 m. Nat'l Broad. Station. 11.30 am.-1.30 pm. Irregular.	11.560	VIZ3	FISKDALE, AUSTRALIA, 25.95 m., Addr. Amalgamated Wireless of Australasia Ltd. Tests irregularly.	10.220	PSH	RIO DE JANEIRO, BRAZIL, 29.35 m., Addr. Box 709. Broadcasts 6-9 pm.
11.840	OLR4A	PRAGUE, CZECHOSLOVAKIA, 25.35 m., Addr. Czech Shortwave Sta., Praha XII, Fochova 16. Daily 1.55-4.40 pm. Irregular. 8-10 pm.	11.530	SPD	WARSAW, POLAND, 26 m., Addr. 5 Mazowiecka St. 6-8 pm., Sat. & Sun. 6-9 pm.	10.160	RIO	BAKOU, U.S.S.R., 29.5 m. Works Moscow 10 pm.-7.30 am.
11.830	W9XAA	CHICAGO, ILL., 25.36 m., Addr. Chicago Federation of Labor. Irregular 7 am.-6 pm.	11.500	XAM	MERIDA, YUCATAN, 26.09 m. Irregular 1-7.30 pm.	10.140	OPM	LEOPOLDVILLE, BELGIAN CONGO, 29.59 m., Works Belgium 1-3 am. and 3-5 pm.
11.830	W2XE	NEW YORK CITY, 25.36 m., Addr. Col. Broad. System, 485 Madison Av., N.Y.C. 5.30-10 pm.	11.500	PMK	BANDOENG, JAVA, 26.09 m. Tests irregularly.	10.080	RIR	TIFLIS, U.S.S.R., 29.76 m. Works Moscow 12 m.-8 am.
11.826	XEBR	HERMOSILLA, SON., MEX., 25.37 m., Addr. Box 68. Relays XEBH. 1-4 pm., 9 pm.-12 m.	11.413	CJA4	DRUMMONDVILLE, QUE., CAN., 26.28 m. Tests irregularly.	10.065	TDE	SHINKYO, MANCHUKUO, 29.81 m. Works JVO 3-8 am.
11.820	GSN	DAVENTRY, ENG., 25.38 m., Addr. (See 26.100 mc.) Irregular.	11.402	HBO	GENEVA, SWITZERLAND, 26.31 m., Addr. Radio Nations. Sun. 7-7.45 pm., Mon. 1-1.15 am.	10.055	ZFB	HAMILTON, BERMUDA, 29.84 m. Works N.Y.C. irregular.
11.810	ZRO	ROME, ITALY, 25.4 m., Addr. E.I.A.R., Via Montello S. Daily 5-8.45 am., 10 am.-9 pm.	11.050	ZLT4	WELLINGTON, NEW ZEALAND, 27.15 m. Works Australia and England early morning.	10.055	SUV	ABOU ZABAL, EGYPT, 29.84 m. Works Europe 1-6 pm.
11.805	COGF	MATANZAS, CUBA, 25.41 m., Addr. Gen. Betancourt St. Relays CMGF. 2-3, 4-5, 6-11 pm.	11.040	CSW	LISBON, PORTUGAL, 27.17 m., Addr. Nat. Broad. Sta. 1.30-5 pm.	10.042	DZB	ZEESEN, GERMANY, 29.87 m., Addr. Reichspostzentratam. Irregular.
11.805	OZG	SKAMLEBOAOK, DENMARK, 25.41 m. Addr. Statsradiofonen. Irreg.	11.000	PLP	BANDOENG, JAVA, 27.27 m. Relays YDB. 6-7.30 p.m., 5.30-10.30 or 11 am. Sat. until 11.30 am.	9.990	KAZ	MANILA, P. I., 30.03 m., Addr. RCA Communications. Works Java early morning.
11.800	ZJZ	TOKYO, JAPAN, 25.42 m., Addr. Broadcasting Co. of Japan, Overseas Division. 7-7.30, 8-9.30 am., 2.30-4, 4.30-5.30 pm.	10.970	OCI	LIMA, PERU, 27.35 m. Works Bogota, Col., evenings.	9.980	COBC	HAVANA, CUBA, 30.04 m., Addr. P. O. Box 132. Relays CMBC 6:55 a.m.-12:30 a.m.
11.795	DJO	BERLIN, GERMANY, 25.43 m., Addr. (See 15.280 mc.) 7.15-11 pm.	10.960	—	TANANARIVE, MADAGASCAR, 27.36 m., Addr. (See 9.53 mc.) 12.30-45, 3.30-4.30, 10-11 am.	9.950	GCU	RUGBY, ENGLAND, 30.15 m. Works N.Y.C. night time.
11.790	—	VIENNA, AUSTRIA, 25.45 m. Irreg.	10.910	KTR	MANILA, P. I. 27.41 m. Phones ships 6-10 am.	9.940	JDY	DAIREN, MANCHUKUO, 30.18 m. Relays JQAK daily 7-8 am. Works Tokyo occasionally in early am.
11.790	WIXAL	BOSTON, MASS., 25.45 m., Addr. (See 15.250 mc.) Mon., Wed., Fri. 3.30-5.30 pm., Sat. 5.5-3.30 pm., Sun. 2-4.30 pm.	10.840	KVV	DIXON, CALIF., 27.68 m., Addr. A.T.&T. Co. Works with Hawaii evenings.	9.930	HKB	BOGOTA, COL., 30.21 m. Works Rio evenings.
11.780	HP5G	PANAMA CITY, PAN., 25.47 m., Addr. Box 1121. Heard till 12 m.	10.770	GBP	RUGBY, ENGLAND, 27.85 m. Works Australia early morning.	9.890	LSN	BUENOS AIRES, ARG., 30.33 m., Addr. (See 10.300 mc.) Works N.Y.C. evenings.
11.770	DJD	BERLIN, GERMANY, 25.49 m., Addr. (See 15.280 mc.) 10.40 am.-4.30 pm., 4.50-11 pm.	10.740	JVM	NAZAKI, JAPAN, 27.93 m. Works U.S.A. 2-7 am.	9.870	WON	LAWRENCEVILLE, N. J., 30.4 m., Addr. A.T.&T. Co. Works England nights.
11.760	TGWA	GUATEMALA CITY, GUAT., 25.51 m. (See 17.8 mc.) Irregular 10-11.30 pm. Sun. 6-11.30 pm., irregular.	10.680	PLQ	BANDOENG, JAVA, 28.09 m. Works Javanese Isles and other Asiatic phones 6-8.30 am.	9.865	COCM	HAVANA, CUBA, 30.41 m., Addr. Transradio Columbia, P. O. Box 33. 7 am.-12 m. Relays CMCM.
11.760	OLR4B	PRAGUE, CZECHOSLOVAKIA, 25.51 m., Addr. (See 11.840 mc.) Irregular.	10.675	WNB	LAWRENCEVILLE, N. J., 28.1 m., Addr. A.T.&T. Co. Works with Bermuda irregularly.	9.860	EAQ	MADRID, SPAIN, 30.43 m., Addr. Post Office Box 951. 7.30-8, 8.40-9 pm.
11.750	GSD	DAVENTRY, ENG., 25.53 m., Addr. B.B.C., London. 1-3.15 am., 12.17-4.00 pm., 6.17-8.30, 9.17-11.20 pm.	10.670	CEC	SANTIAGO, CHILE, 28.12 m. Irregular.	9.830	IRF	ROME, ITALY, 30.52 m. Works Egypt afternoons. Relays ZRO, 6-9 pm.
			10.660	JVN	NAZAKI, JAPAN, 28.14 m. Broadcasts daily 2-8 am. Works Europe irregularly at other times.	9.800	LSI	BUENOS AIRES, ARG., 30.61 m., Addr. (See 10.350 mc.) Tests irregularly.
			10.600	ZIK2	BELIZE, BRIT. HONDURAS, 28.25 m., Tues., Thurs., Sat. 7.30-7.45 pm.	9.790	GCV	RUGBY, ENGLAND, 30.64 m., Works N.Y.C. evenings.
						9.760	CSW	LISBON, PORTUGAL, 30.74 m., Addr. Nat. Broad. Sta. 5-8 pm.
						9.760	VLZ-VLK	SYDNEY, AUSTRALIA, 30.74 m., Addr. Amalgamated Wireless of Australasia Ltd. Works Java and New Zealand early morning.

(Continued on page 284)

All Schedules Eastern Standard Time



# Radio Kinks

Each month the Editor will award a 2 year subscription for the best kink submitted. All other kinks published will be awarded eight months' subscription to **SHORT WAVE & TELEVISION**. Look over these kinks: they will give you some idea of what is wanted. Send a typewritten or ink description, with sketch, of your favorite to the Kink Editor.

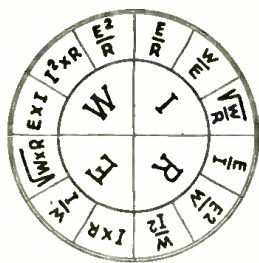

W=WATTAGE I=CURRENT  
R=RESISTANCE E=VOLTAGE

## Ohm's Law

1st Prize

This is one of the cleverest reference charts for Ohm's Law which we have ever seen. Each quadrant of the circle gives one unknown quantity and three formulas for finding it. Thus, W equals  $EI$ ,  $I^2R$  or  $\frac{E^2}{R}$

Similarly, where I, R or E are unknown, they may be found by reference to the chart.—*Manuel Madridano*.

## Spare Tubes

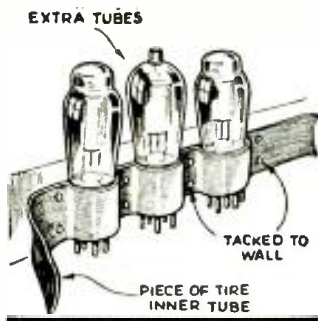

A simple kink for storing spare tubes is to keep a strip of rubber from an old inner tube tacked on the wall, as shown. Spare tubes are slipped into the loops of the tubing, out of harm's way.—*Anthony French*.

## Cleans Teeth, Too

A tooth brush can be a very handy tool around the work-bench. It can be used to clean solder from inside of coils and to remove dust from between prongs of tubes and sockets. Dust adhering to chassis and coil windings is also easily removed. If the handle is made of a plastic it can be bent by placing in hot water. Then the handle may be used to get into out of the way places in radio equipment.

We would advise a separate brush for cleaning the teeth, however.—*Joseph Lisains*.

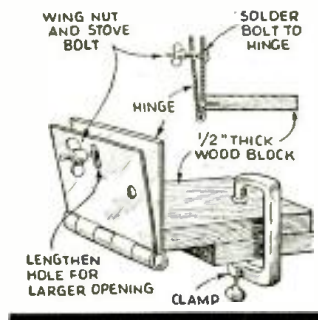

## A Nice Vise

A makeshift vise can be fashioned from an old shutter hinge; one having a length of 3" should be satisfactory. A small piece of wood 1/2" thick and an inch long is used to mount the hinge as shown in the drawing. Flat headed wood screws of about 1" length may be used to secure the hinge to the block. A 10/24 machine screw and a wing-nut complete the assembly. The wood block can be secured to the bench by means of a C clamp. This vise is useful for all kinds of small work.—*F. J. Link*.



## Coil Winding

When winding transmitter inductances from copper tubing, the tubing may be wound without danger of collapsing or kinking if a cork is placed in one end of the tube and sand poured into the other end, filling the tube completely. The other end should then be corked, too.

The sand exerts an equal internal pressure against the walls of the form upon which the tubing is wound and the result is a coil without kinks. Of course, the sand should be removed when winding is completed.—*Donald E. A. Rose*.

## Grid Leads

Receivers using plug-in coils and tubes with the grid lead coming to a cap at the top of the tube can be benefited by this kink. A separate lead is brought out from the grid prong of the plug-in coil to the top of the coil and attached to a grid clip. In this way the connection from the grid coil to the tube is made more direct, than when bringing a separate connection from the coil socket up through the chassis to the grid cap of the tube.—*John Winegard*.

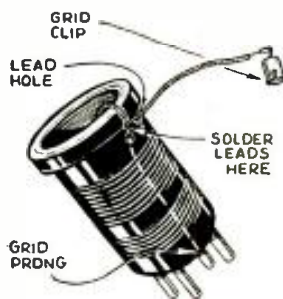

## Regeneration Control

A supplementary regeneration control for a detector stage is shown in the sketch. R1 is made variable and is used as a supplement to the normal regeneration control R. R1 has the advantage that it adjusts the voltage on the detector tube plate. To operate, set R1 until the set is about to go into regeneration and then use R as the vernier control. It will be found that R1 will also tend to act as an audio volume control, which is useful in certain conditions.—*Merle V. Hoover*.

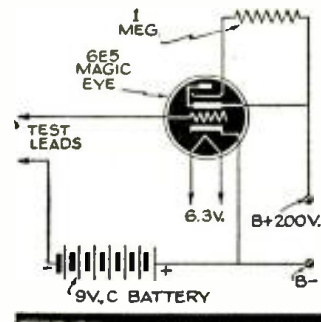
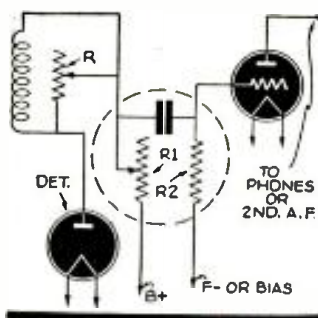

## Continuity Tester

Another use for the 6E5 tuning tube is as an insulation and continuity tester. The tube is hooked up, as shown in the diagram, and the two test prods are connected to the object whose insulation is to be tested. If the shadow pattern closes, it is an indication that the insulation is poor, but if the shadow remains open, the insulation is good. When using the device for continuity tests, if the continuity is O.K., the shadow pattern should close up.—*J. M. Shank*.

## A Nutty Idea

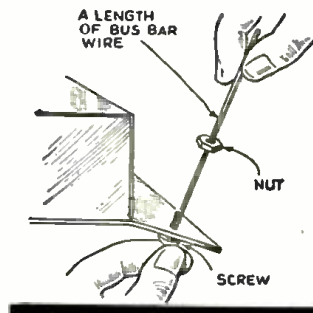

The experimenter often has difficulty in starting a nut on a machine screw, especially when the screw is located in an out of the way position. This simple kink is a great time-saver in this case. Slip the nut on a length of bus bar wire and, holding it at the upper end of the wire, place the far end of the bus bar on the machine screw as shown. Release the nut and it will slide down to a position where it may be started by spinning it with another piece of wire or a long handled screw-driver.—*Ray Kailbuorn*.

Mc.	Call	Station
9.760	—	SAIGON, INDO-CHINA, 30.72 m., Addr. 17, Place A. Foray. "Radio Boy-Landry." Heard 6-9.15 am.
9.750	WOF	LAWRENCEVILLE, N. J., 30.77 m., Addr. A.T.&T. Co. Works London and Paris night time.
9.720	COCQ	HAYANA, CUBA, 30.85 m. Addr. 25 No. 445, Vedado, Havana, 6.55 am.-1 am. Sun. till 12 m.
9.710	GCA	RUGBY, ENGLAND, 30.9 m. Works S. A. evenings.
9.700	FZF6	FORT DE FRANCE, MARTINIQUE, 30.9 m., Addr. P. O. Box 136, 11.30 am.-12.30 pm., 6.15-7.50 pm.
9.690	TI4NRH	HEREDIA, COSTA RICA, 30.94 m., Addr. Amado C. Marin, Apar- tado 40. Sun. 7-8 am. Tues. Thurs., Sat. 9-10 pm.
9.685	TGWA	GUATEMALA CITY, GUAT., 30.96 m. Daily 10-11.30 pm.; Sun. 6- 11.30 pm.
9.675	DZA	ZEESEN, GERMANY, 31.01 m., Addr. (See 10.042 mc.) Irregular.
9.660	LRX	BUENOS AIRES, ARG., 31.06 m., Addr. El Mundo. Relays LR1, 9.30 am.-11.30 pm.
9.650	CS2WA	LISBON, PORTUGAL, 31.09 m., Addr. Radio Colonial. Tues., Thurs. and Sat. 3.30-6 pm.
9.650	DGU	NAUEN, GERMANY, 31.09 m., Addr. (See 20.020 mc.) Works Egypt afternoons.
9.645	HH3W	PORT-AU-PRINCE, HAITI, 31.1 m., Addr. P. O. Box A117. 1-2, 7-8 pm.
9.640	CXA8	COLONIA, URUGUAY, 31.12 m., Addr. Belgrano 1841. Buenos Aires, Argentina. Relays LR3, Buenos Aires 7 am.-11 pm.
9.635	ZRO	ROME, ITALY, 31.13 m., Addr. (See 11.810 mc.) Daily 3-6 pm.
9.630	HJ7ABD	BUCARAMANGA, COL., 31.14 m. 10 am.-12 n., 4-11 pm.
9.625	JFO	TAIHOKEU, TAIWAN, 31.16 m. Re- lays JFAK irreg. 4-10 am.
9.616	HJIABP	CARTAGENA, COL., 31.20 m., Addr. P. O. Box 37. 11 am.-1 pm., 5-11 pm., Sun. 10 am.-1 pm., 3- 6 pm.
9.615	ZRK	KLIPHEUVAL, SOUTH AFRICA, 31.2 m., Addr. P. O. Box 4559, Johannesburg. Daily, exc. Sat. 11.45 pm.-12.50 am. Daily exc. Sun. 3.20-7.20, 9-11.45 am., Sun. 3.30-4.30 or 4-5, 5.30-7, 9-11.45 am.
9.607	HP5J	PANAMA CITY, PANAMA, 31.23 m. Addr. Apartado 867. 12 n. to 1.30 pm., 6-10.30 pm.

### 31 Met. Broadcast Band

9.600	RAN	MOSCOW, U.S.S.R., 31.25 m. Daily 7-9.15 pm.
9.595	HBL	GENEVA, SWITZERLAND, 31.27 m., Addr. Radio Nations. Irregular.
9.590	VUD21 VUD3	DELHI, INDIA, 31.28 m. Addr. All India Radio, 8.30-10.30 pm., 1.30-3.30 am., 7.30 am.-12.30 pm.
9.590	PCJ	HUIZEN, HOLLAND, 31.28 m., Addr. (See 15.220 mc.) Sun. 2-3, 7-9.25 pm., Tues. 1.45-3.40, 7-10.15 pm., Wed. 7-9 pm.
9.590	YK6ME	PERTH, W. AUSTRALIA, 31.28 m., Addr. Amalgamated Wireless of Australasia, Ltd. 6-8 am. exc. Sun.
9.590	YK2ME	SYDNEY, AUSTRALIA, 31.28 m., Addr. Amalgamated Wireless of Australasia, Ltd., 47 York St., Sun. 12 m.-2 am.; 4.30-8.30 am.; 11.30 am.-1.30 pm.
9.590	W2XE	NEW YORK, N. Y., 31.28 m., Addr. CBS, 485 Madison Ave., Irregu- lar.
9.590	W3XAU	PHILADELPHIA, PA., 31.28 m. Re- lays WCAU Mon., Thurs., Sat. 12 n.-12 m.; Tues., Fri., Sun. 11 pm.-12 m.; Wed. 9 pm.-12 m.
9.580	GSC	DAVENTRY, ENGLAND, 31.32 m., Addr. B. B. C., Portland Pl., London, W. 1, 9.17-11.20 pm.
9.680	VLR	MELBOURNE, AUSTRALIA, 31.32 m. Addr. Box 1686, G. P. O. Daily 3.30-8.30 am. (Sat. till 9 am.) Sun. 3-7.30 am. Daily exc. Sat. 9.35 pm.-2.15 am.
9.580	OAX5C	ICA, PERU, 31.32 m. Radio Uni- versal 6-10 pm.

9.570	KZRM	MANILA, P. I., 31.35 m., Addr. Erlanger & Galinger, Box 283. Sun. 3-10 am. Daily exc. Sat. 4.30-7 pm., 11.15 pm.-12.15 am. Daily exc. Sun. 4-10 am.
9.570	WIXK	SPRINGFIELD, MASS., 31.35 m., Addr. Westinghouse Electric & Mfg. Co. Relays WBZ 6 am. to 12 m. Sun. 7 am.-12 m.
9.560	DJA	BERLIN, GERMANY, 31.38 m., Addr. Broadcasting House. 12.05- 11 am., 4.50-10.45 pm.
9.550	TPB11	PARIS, FRANCE, 31.41 m. Addr. (See 15.245 mc.) 1-3 am., 10.15 am.-5 pm.
9.550	W2XAD	SCHENECTADY, N. Y., 31.41 m., General Electric Co., 6.30-10 pm.
9.550	OLR3A	PRAGUE, CZECHOSLOVAKIA, 31.41 m. (See 11.840 mc.) Mon., Tues. 4.40-5.10 pm.
9.550	XEFT	VERA CRUZ, MEX., 31.41 m. 10.30 am.-4.30 pm., 10.30 pm.-12.30 am.
9.550	YDB	SOERABAJA, JAVA, 31.41 m., Addr. N.I.R.O.M. Daily exc. Sat. 6-7.30 pm., 5.30 to 10 am. Sat. 5.30-11.30 am.
9.550	VUB2	BOMBAY, INDIA, 31.41 m., Addr. All India Radio. 1-3.30 am.
9.540	DJN	BERLIN, GERMANY, 31.45 m., Addr. (See 9.560 mc.) 4.50-10.45 pm.
9.540	VPD2	SUVA, FIJI ISLANDS, 31.45 m., Addr. Amalgamated Wireless of Australasia, Ltd. 5.30-7 am.
9.535	JZI	TOKYO, JAPAN, 31.46 m., Addr. (See 11.800, JZJ) Irregular.
9.535	HB9D	ZURICH, SWITZERLAND, 31.46 m., Addr. Radio Club of Zurich, Post Box Zurich 2. Sun. 9-11 am., Thur. 1-3 pm.
9.530	W2XAF	SCHENECTADY, N. Y., 31.48 m., Addr. General Electric Co. 3-11 pm.
9.530	ZHO	SINGAPORE, MALAYA, 31.48 m., Mon.-Fri. 12.40-1.40 am., Sat. 12.25-1.40 am., 10.40 pm.-1.10 am. Irreg. 5.40-9.40 am.
9.526	XEDQ	GUADALAJARA, GAL., MEXICO, 31.49 m. Irregular 7.30 pm. to 12.30 am.
9.526	ZBW3	HONGKONG, CHINA, 31.49 m., Addr. P. O. Box 200. 11.30 pm. to 1 am., 3-10 am.
9.525	LKJ1	JELOY, NORWAY, 31.49 m. 5-8 am.
9.523	ZRH	ROBERTS HEIGHTS, S. AFRICA, 31.5 m., Addr. (See ZRK, 9.606 mc.) Daily exc. Sun. 5-7.30 am.; Sun. 5.30-7 am.
9.520	HJ4ABH	ARMENIA, COLOMBIA, 31.51 m. 6-10 pm.
9.520	OZF	SKAMLEBOAEK, DENMARK, 31.51 m., Addr. Statsradiofonien, Heib- ergsgade 7, Copenhagen., 2-6.40, 8-11 pm.
9.520	YSH	SAN SALVADOR, EL SALVADOR 31.51 m., Addr. (See 7.894 mc.) Irregular 6-10 pm.
9.510	GSB	DAVENTRY, ENGLAND, 31.55 m., Addr. (See 9.580 mc.—GSC) 1-3.15 am., 1.30-6, 6.17-9, 9.17- 11.20 pm.
9.510	HJU	BUENAVENTURA, COLOMBIA, 31.55 m., Addr. National Rail- ways. Mon., Wed. and Fri. 8- 11 pm.
9.500	YK3ME	MELBOURNE, AUSTRALIA, 31.58 m., Addr. Amalgamated Wireless of Australasia, 167 Queen St. Daily except Sun. 4-7 am.
9.500	XEWV	MEXICO CITY, MEX., 31.58 m., Addr. Apart. 2516. Relays XEW. 6 pm.-12 m.
9.500	—	LAHTI, FINLAND, 31.58 m., Addr. Finnish Broadcasting Co. 2-5 pm.
9.500	HS8PJ	BANGKOK, SIAM, 31.58 m. Thurs- day, 8-10 am.
9.488	EAR	MADRID, SPAIN, 31.6 m., Addr. (See 9.860 mc.) 7.30-8.30 pm. Mon., Tues., Thur., Sat. at 9.30 pm. also.

### End of Broadcast Band

9.460	ICK	TRIPOLI, N. AFRICA, 31.71 m. Works Rome, 5.30-7 am.
9.445	HCOD	GUAYAQUIL, ECUADOR, 31.77 m. Irregularly till 10.40 pm.
9.428	COCH	HAYANA, CUBA, 31.8 m., Addr. 2 B St., Vedado, 7 am.-1 am.
9.415	PLV	BANDOENG, JAVA, 31.87 m. Works Holland 5.30-9 am.

9.380	—	TANANARIVE, MADAGASCAR, 31.96 m. Addr. Le Directeur des PTT, Radio Tananarive, Adminis- tration PTT. 12.30-12.45, 3.30-4.30, 10.11 am.
9.355	HCIETC	QUITO, ECUADOR, 32.05 m., Addr. Teatro Bolivar, Thurs. un- til 9.30 p.m.
9.345	HBL	GENEVA, SWITZERLAND, 32.08 m., Addr. Radio Nations Fri., 7:15- 8:30 p.m., 6:45-8 p.m.
9.330	CGA4	DRUMMONDVILLE, CANADA, 32.15 m. Works England irreg.
9.330	OAX4J	LIMA, PERU, 32.15 m., Addr. Box 1166, "Radio Universal." 12 n.- 3 pm., 5 pm.-1 am.
9.290	HIG	CIUDAD TRUJILLO, D. R., 32.29 m. 7.10-8.40 am., 11.40 am.-2.10 pm., 3.40-8.40 pm.
9.280	HC2CW	GUAYAQUIL, ECUADOR, 32.31 m., 11.30 am.-12.30 p.m., 8-11 pm.
9.280	GCB	RUGBY, ENGLAND, 32.33 m. Works Canada and Egypt eve- nings and afternoons.
9.200	COBX	HAYANA, CUBA, 32.59 m. Addr. San Miguel 194, Altos. Relays CMBX 7 am.-12 m.
9.180	ZSR	KLIPHEUVEL, SOUTH AFRICA, 32.66 m. Phones London late afternoon.
9.170	WNA	LAWRENCEVILLE, N. J., 32.72 m. Works England evenings.
9.150	YVR	MARACAY, VENEZUELA, 32.79 m. Works with Europe afternoons.
9.125	HAT4	BUDAPEST, HUNGARY, 32.88 m., Addr. "Radiolabor." Gyali-ut, 22. Sun. and Wed. 7-8 pm., Sat. 6-7 pm.
9.120	YCP	BALIKPAPAN, DUTCH BORNEO, 32.88 m. Phones Bandoeng 5.30- 7.30 am.
9.100	COCA	HAYANA, CUBA, 32.95 m., Addr. Galiano No. 102. Relays CMCA 9 am.-12 m.
9.060	TFK	REYKJAVIK, ICELAND, 33.11 m. Works London afternoons.
9.030	TYA2	PARIS, FRANCE, 33.2 m. Works TPZ2 near 2 am. and 4-5 pm.
9.020	COBZ	HAYANA, CUBA, 33.26 m., Radio Salas Addr. P. O. Box 866, 7:45 am.-12.10 am. Irreg. 12.30-2 am. Relays CMBZ.
9.020	GCS	RUGBY, ENG., 33.26 m. Works N. Y. C. evenings.
9.010	KEJ	BOLINAS, CAL., 33.3 m. Relays NBC and CBS programs in eve- ning irregularly.
8.967	VWY	KIRKEE, INDIA, 33.43 m. Works with England 1.30-3 am.
8.965	COKG	SANTIAGO, CUBA, 33.44 m. Addr. Box 137, 9-10 am., 11.30 am.-1.30 pm., 3-4.30, 5-6, 10-11 pm., 12 m.-2 am.
8.960	TPZ2	ALGIERS, ALGERIA, 33.48 m. Works TYA2, near 2 am. and 4-5 pm.
8.841	HCJB	QUITO, ECUADOR, 33.5 m., 7-8.30 am., 11.45 am.-2.30 pm., 5-10 pm., except Mon. Sun. 12 n.- 1.30 pm., 5.30-10 pm.
8.840	ZMBJ	S.S. AWATEA, 33.92 m. Steamer out of New Zealand. Saturday at 11 pm. Phones Australia early am, irregularly.
8.775	PNI	MAKASSER, CELEBES, N.J., 34.19 m. Works Java around 4 am.
8.765	DAF	NORDDEICH, GERMANY, 34.23 m. Works German ships irregularly.
8.760	GCQ	RUGBY, ENG., 34.25 m. Works Africa afternoons.
8.730	GCI	RUGBY, ENG., 34.36 m. Works India 8 am.
8.700	HKV	BOGOTA, COLOMBIA, 34.46 m. Tues. and Fri. 7-7.20 pm.
8.660	GBC	RUGBY, ENG., 34.56 m. Works ships irregularly.
8.665	COJK	CAMAGUEY, CUBA, 34.64 m., Addr. Finlay No. 3 Altos. 5.30- 6.30, 8-11 pm., daily except Sat. and Sun.
8.665	W2XGB	HICKSVILLE, N. Y., 34.64 m., Addr. Press Wireless, Mon. to Fri. News at 9 am. and 5 pm.
8.580	YNPR	MANAGUA, NICARAGUA, 34.92 m. Radiodifusora Pilot.
8.560	WAQ	OCEAN GATE, N. J., 35.05 m. Works ships irregularly.
8.380	IAC	PISA, ITALY, 35.8 m. Works Italian ships irregularly.

(Continued on page 286)

All Schedules Eastern Standard Time



# New Experiments with Radio Apparatus

Each month we will award 2 prizes, the first—2 years' subscription, the second—1 year's subscription, for the best non-radio uses of ordinary radio parts and radio instrumentalities.

## 1st Prize—2 yrs'. Subscription    2nd Prize—1 yr's Subscription

### Deaf-Aid V.T. Amplifier

● AN amplifier of the resistance-coupled type, suitable for use with a deaf-aid instrument, is shown in the accompanying diagram. The microphone may be a carbon grain or other suitable type and the battery for it can be one of the new compact types, giving 3 to 4½ volts. The transformer coupling the mike to the first amplifier tube may be a 3 to 1 audio type, or it may be a microphone coupling transformer with a fairly low impedance primary. A set of the special Hi-vac tubes, indicated in the diagram, or any of the low voltage battery type tubes may be used. The Hi-vac tubes of the midget type save quite a little space. The batteries may be arranged in a special cloth belt, provided with pockets, so as to fit around the waist. Where desirable, the phone used in the output circuit of the last

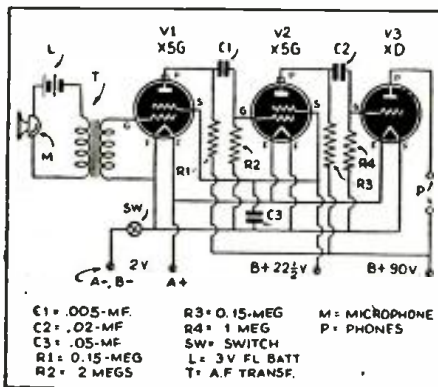

Amplifier circuit for Deaf-Aid Instrument.

tube may be one of the new extremely small miniature headphones. These are now available on the market with a sufficiently high impedance to operate directly in the plate circuit. Extra small a.f. transformers may be picked up at radio supply stores, or if a small one is not available, one could reduce the weight of the ordinary transformer by cutting away part of the core, or by rearranging the coils on a new core made of soft iron wire.—B. B. TRINE.

### Sensitive Relay

● I AM submitting a sketch of a sensitive relay circuit. This relay is actuated by simply touching the operating wire while standing on the ground. Such a circuit can

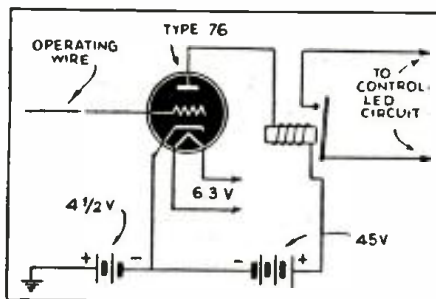

Touching the operating wire sets off the relay and the alarm on other device.

be used for an ultra-sensitive burglar alarm, by placing the fine operating wire on a door knob, window sill, etc., so that the relay is set off when the wire is touched. Even when a very high resistance connection is made between wire and ground, it will be found that this system works successfully.—ROBERT SMITH.

### Induction Coil from Transformer

● MANY experimenters have an old a.f. transformer lying about, and the accompanying sketch shows how an improvised induction coil (for shocking or producing

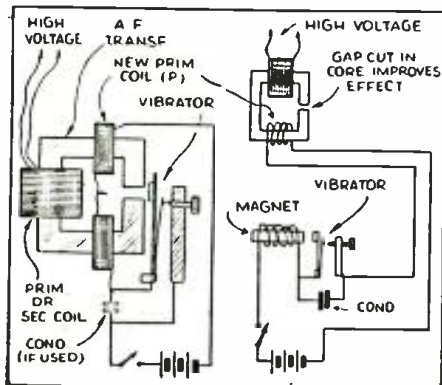

Induction coil made from an A.F. transformer.

sparks) may be made from this transformer. A piece of the iron core is cut away so as to leave a gap and opposite this gap the iron button of the vibrator is mounted. For the primary winding, a small coil may be wound on each leg of the transformer core, each comprising about 50 turns of No. 18 insulated magnet wire. The voltage induced in the secondary can be increased by connecting a small condenser across the vibrator. Best results are usually obtained with batteries as the exciting power, although low-voltage a.c. from a step-down transformer may be employed. The size of the condenser connected across the vibrator may be about 0.1 to 0.25 mf.—H. S.

### An Emergency Plug

● I FOUND, by removing the pins from an old 4-prong tube base, the holes were spaced O.K. for the pins on a corn popper. I then sawed off a piece of the first tube base, so that the pins would stick out of the holes about one-eighth of an inch. Next, I slipped a pair of closely fitting lugs on the ends of the pins and soldered them there. The cord is attached to these.—FRANK L. PULASKI.

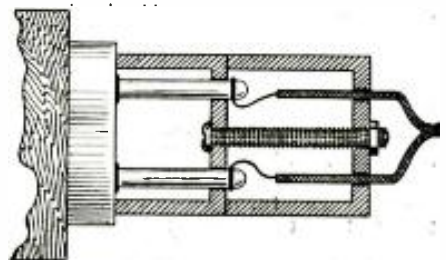

An emergency plug for electrical apparatus

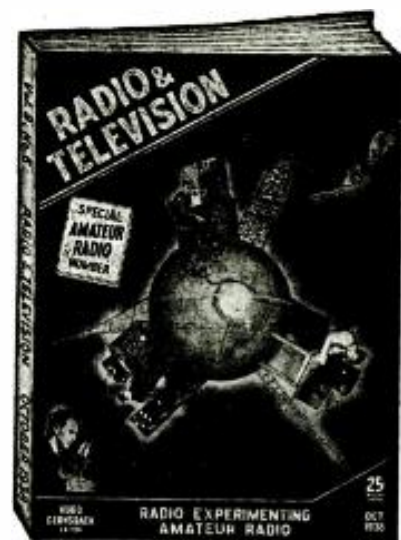

With the October number, *Short Wave & Television* will change its name to **RADIO & TELEVISION**. See inside front cover for details.

Mc.	Call	Mc.	Call	Mc.	Call
8.185	PSK	RIO DE JANEIRO, BRAZIL, 36.65 m. Irregularly.	6.675	H8Q	GENEVA, SWITZERLAND, 44.94 m. Addr. Radio-Nations. Sun. 1.45-2.30 pm.
8.036	CNR	RABAT, MOROCCO, 37.33 m. Works Paris irreg. in afternoons.	6.672	—	44:94 m., relays Salamanca, Spain, 7-9.45 pm.
7.901	LSL	BUENOS AIRES, ARGENTINA, 37.97 m. Works Brazil at night.	6.672	YVQ	MARACAY, VENEZUELA, 44.95 m. Irregular.
7.894	YSD	SAN SALVADOR, EL SALVADOR, 37.99 m., Addr. Dir. Genl. Tel. & Tel. 7-11 pm.	6.650	IAC	PISA, ITALY, 45.11 m. Works ships irregularly.
7.870	HCIRB	QUITO, ECUADOR, 38.1 m. La Voz de Quito. 9-11 pm.	6.635	HC2RL	GUAYAQUIL, ECUADOR, S. A., 45.18 m., Addr. P. O. Box 759. Sun. 5.45-7.45 pm., Tues. 9.15-11.15 pm.
7.860	SUX	ABOU ZABAL, EGYPT, 38.17 m. Works with Europe, 4-6 pm.	6.630	HIT	CIUDAD TRUJILLO, D. R., 45.25 m., Addr. "La Voz de la RCA Victor." Apartado 1105. Daily exc. Sun. 12.10-1.40 pm., 5.40-8.40 pm.; also Sat. 10.40 pm.-12.40 am.
7.854	HC2JSB	GUAYAQUIL, ECUADOR, 38.2 m. Evenings to 11 pm.	6.625	PRADO	RIOBAMBA, ECUADOR, 45.28 m. Thurs. 9-11.45 pm.
7.797	HBP	GENEVA, SWITZERLAND, 38.48 m., Addr. Radio-Nations.	6.558	HI4D	CIUDAD TRUJILLO, D. R., 45.74 m. Except Sun. 11.55 am.-1.40 pm.
7.780	PSZ	RIO DE JANEIRO, BRAZIL, 38.54 m. Phones 6-11 pm. irregularly.	6.550	XBC	VERA CRUZ, MEX., 45.8 m. 8.15-9 am.
7.715	KEE	BOLINAS, CAL., 38.89 m. Relays NBC and CBS programs in evening irregularly.	6.550	TIRCC	SAN JOSE, COSTA RICA, 45.8 m., Addr. Radioemisora Catolica Costarricense. Sun. 11 am.-2 pm., 6-7, 8-9 pm. Daily 12 n.-2 pm., 6-7 pm., Thurs. 6-11 pm.
7.680	YBZ	MENADO, CELEBES, N.E.I., 39.04 m. Phones PNI and Bandoeng, 5.30-7 am.	6.545	YV6RB	BOLIVAR, VENEZUELA, 45.84 m., Addr. "Ecos de Orinoco." 6-10.30 pm.
7.626	RIM	TACHKENT, U.S.S.R., 39.34 m. Works with Moscow in early morning.	6.520	YV4RB	VALENCIA, VENEZUELA, 45.98 m. 11 am.-2 pm., 5-10 pm.
7.610	KWX	DIXON, CAL., 39.42 m. Works with Hawaii, Philippines, Java and Japan, nights.	6.516	YNIGG	MANAGUA, NICARAGUA, 46.02 m., Addr. "La Voz de las Lagos." 8-9 pm.
7.560	FZE9	DJIBOUTI, FRENCH SOMALI-LAND, 39.66 m. Phones Paris early am.	6.500	HIL	CIUDAD TRUJILLO, D. R., 46.13 m. Addr. Apartado 623. 12.10-1.40 pm., 5.40-7.40 pm.
7.540	RKI	MOSCOW, U.S.S.R., 39.76 m. Works RIM early am.	6.490	HIIL	SANTIAGO DE LOS CABALLEROS, D. R., 46.2 m., Addr. Pres., Trujillo 97, Altos., 5.40-7 pm.
7.520	KKH	KAHUKU, HAWAII, 39.87 m. Works with Dixon and broadcasts irregularly nights.	6.470	YNLAT	GRANADA, NICARAGUA, 46.36 m., Addr. Leonidas Tenorio, "La Voz del Mombacho." Irregular.
7.510	JVP	NAZAKI, JAPAN, 39.95 m. Irreg.	6.465	YV3RD	BARQUISIMETO, VENEZUELA, 46.37 m. Radio Barquisimeto, irregular.
7.410	HCJ84	QUITO, ECUADOR, 40.46 m., 7-9.30 pm. irregularly.	6.450	HI4V	SAN FRANCISCO DE MACORIS, D. R., 46.48 m. 11.40 am.-1.40 pm., 5.10-9.40 pm.
7.390	ZLT2	WELLINGTON, N. Z., 40.6 m. Works with VLZ near 4 am.	6.440	TGQA	QUEZALTENANGO, GUATEMALA, 46.56 m. Mon.-Fri. 9-11 pm., Sat. 9 pm.-1 am., Sun. 1-3 pm.
7.380	XECR	MEXICO CITY, MEX., 40.65 m., Addr. Foreign Office. Sun. 6-7 pm.	6.420	HIIS	SANTIAGO, D. R., 46.73 m. 11.40 am.-1.40 pm., 5.40-7.40, 9.40-11.40 pm.
7.220	HKE	BOGOTA, COL., S. A., 41.55 m. Tues. and Sat. 8-9 pm. Mon. and Thurs. 6.30-7 pm.	6.416	YV6RC	BOLIVAR, VENEZUELA, 46.73 m. Radio Bolivar.
7.200	YNAM	MANAGUA, NICARAGUA, 41.67 m. Irregular at 9 pm.	6.410	TIPG	SAN JOSE, COSTA RICA, 46.8 m., Addr. Apartado 225, "La Voz de la Victor." 12 n.-2 pm., 6-11.30 pm.
7.177	CR6AA	LOBITA, ANGOLA, PORT. WEST AFRICA, 41.75 m., Wednesday and Saturday 2.45-4.30 pm.	6.400	YV5RH	CARACAS, VENEZUELA, 46.88 m. 7-11 pm.
7.100	F08AA	PAPEETE, TAHITI, 42.25 m., Addr. Radio Club Oceanien. Tues. and Fri. 11 pm.-12.30 am.	6.388	HIBJ	LAS VEGAS, D. R., 46.92 m., Irreg.
7.088	PIIJ	DORDRECHT, HOLLAND, 42.3 m., Addr. Dr. M. Hellingman, Technical College. Sat. 11.10-11.50 am.	6.384	VP2LO	STE. KITTS, B.W.I. 46.96 m. ICA Service Labs, Box 88, Daily 4-4.45 pm., Sun 10-10.45 am. and irreg. at other times.
6.990	XEME	MERIDA, YUCATAN, 42.89 m., Addr. Calle 59, No. 517, "La Voz de Yucatan desde Merida." Irregular.	6.380	YV5RF	CARACAS, VENEZUELA, 46.92 m., Addr. Box 983. 6-10.30 pm.
6.980	KZGG	CEBU ISLAND, P. I. 42.95 m. Phones Manila near 4 am.	6.370	TI8WS	PUNTARENAS, COSTA RICA, 47.07 m., Addr. "Ecos Del Pacifico", P. O. Box 75. 6 pm.-12 m.
6.977	X8A	TACUBAYA, D. F., MEX., 43 m. 9.30 am.-1 pm., 7-8.30 pm.	6.365	YVIRH	MARACAIBO, VENEZUELA, 47.18 m., Addr. "Ondas Del Lago." Apartado de Correos 261. 6-7.30 am., 11 am.-2 pm., 5-11 pm.
6.905	GDS	RUGBY, ENG., 43.45 m. Works N.Y.C. evenings irregularly.	6.360	HRP1	SAN PEDRO SULA, HONDURAS, 47.19 m. 7.30-9.30 pm.
6.860	KEL	BOLINAS, CALIF., 43.70 m. Tests irregularly, 11 am.-12 n., 6-9 pm.	6.350	JZG	NAZAKI, JAPAN, 47.22 m. Relays Tokyo 5-7.30 am. irreg. Phones ships early am.
6.805	HI7P	CIUDAD TRUJILLO, DOM. REP., 44.06 m., Addr. Emisoria Diaria de Comercio. Daily exc. Sat. and Sun. 12.40-1.40, 6.40-8.40 pm. Sat. 12.40-1.40 pm. Sun. 10.40 am.-11.40 am.	6.340	HIIX	CIUDAD TRUJILLO, D. R., 47.32 m. Sun. 7.40-10.40 am., daily 12.10-1.10 pm., Tues. and Fri. 8.10-10.10 pm.
6.790	PZH	PARAMIRABO, SURINAM, 44.16 m., Addr. P. O. Box 18. Daily 6.06-8.36 am., Sun. 9.36-11.36 am. Daily 5.36-8.36 pm.	6.335	OAXIA	ICA, PERU, 47.33 m., Addr. La Voz de Chiclayo, Casilla No. 9. 8-11 pm.
6.776	HIH	SAN PEDRO DE MACORIS, DOM. REP., 44.26 m. 12.10-1.40 pm., 7:30-9 pm. Sun. 3-4 am., 4.15-6 pm., 4.40-7.40 pm.	6.324	COCW	HAVANA, CUBA, 47.4 m., Addr. La Voz de las Antillas, P. O. Box 130. 6.55 am.-1 am. Sun. 10 am.-10 pm.
6.765	WOA	LAWRENCEVILLE, N. J., 44.41 m., Addr. A.T.&T. Co. Works Eng. evenings.	6.310	HIZ	CIUDAD TRUJILLO, D. R., 47.52 m. Daily except Sat. and Sun. 11.10 am.-2.25 pm., 5.10-8.40 pm. Sat. 5.10-11.10 pm. Sun. 11.40 am.-1.40 pm.
6.760	JVT	NAZAKI, JAPAN, 44.44 m., Addr. Kokusai-Denwa Kaisha, Ltd., Tokyo. Irregular.			
6.730	HI3C	LA ROMANA, DOM. REP., 44.58 m., Addr. "La Voz de la Feria." 12.30-2 pm., 5-6 pm.			
6.720	PMH	BANDOENG, JAVA, 44.64 m. Relays NIROM programs. 5.30-9 am.			
6.690	TIEP	SAN JOSE, COSTA RICA, 44.82 m., Addr. Apartado 257, La Voz del Tropic. Daily 7-10 pm.			
6.295	OAX4G	LIMA, PERU, 47.63 m., Addr. Apartado 1242, Daily 7-10.30 pm.			
6.290	HIG	TRUJILLO CITY, D. R., 47.67 m. 7.10-8.40 am., 11.40 am.-2.10 pm., 3.40-8.40 pm.			
6.280	COHB	SANCTI SPIRITUS, CUBA, 47.77 m., Addr. P. O. Box 85. 9-11.30 am., 12.30-1.30, 4-7, 8-11 pm.			
6.270	YVSRP	CARACAS, VENEZUELA, 47.79 m., Addr. "La Voz de la Philco." Daily to 10.30 pm.			
6.255	YVSRJ	CARACAS, VENEZUELA, 47.18 m.			
6.243	HIN	CIUDAD TRUJILLO, D. R., 48 m., Addr. "La Voz del Partido Dominicano." 12 n.-2 pm., 6-10 pm.			
6.235	HRD	LA CEIBA, HONDURAS, 48.12 m., Addr. "La Voz de Atlantida." 8-11 pm.; Sat. 8 pm.-1 am.; Sun. 4-6 pm.			
6.225	YVIRG	VALERA, VENEZUELA, 48.15 m. 6-9.30 pm.			
6.210	—	SAIGON, INDO-CHINA, 48.28 m., Addr. Radio Boy-Landry, 17 Place A. Foray. 4.30 or 5.30-9.15 am.			
6.210	TG2	GUATEMALA CITY, GUAT., 48.28 m., Addr. Dir. Genl. of Electr. Commun. Relays TGI Mon.-Fri. 6-11 pm., Sat. 6 pm.-1 am. Sun. 7-11 am., 3-8 pm.			
6.205	YVSR1	CORO, VENEZUELA, 48.32 m., Addr. Roger Leyba, care A. Urbina y Cia. Irregular.			
6.200	HI8Q	CIUDAD TRUJILLO, D. R., 48.36 m. Irregular.			
6.200	ZGE	KUALA LUMPUR, FED. MALAY ST., 48.36 m. Sun., Tue. and Fri. 6.40-8.40 am.			
6.185	HI1A	SANTIAGO, D. R., 48.5 m., Addr. P. O. Box 423. 7 am.-5 pm.			
6.171	XEXA	MEXICO CITY, MEX., 48.61 m., Addr. Dept. of Education. 7-11 pm.			
6.156	YVSRD	CARACAS, VENEZUELA, 48.71 m. 11 am.-2 pm., 4-10.40 pm.			
6.153	HI5N	MOCA CITY, D. R., 48.75 m. 6.40-9.10 pm.			

### 49 Met. Broadcast Band

6.150	CJRO	WINNIPEG, MAN., CANADA, 48.78 m., Addr. (See 11.720 mc.) Daily 6 pm.-12 m., Sun. 5-10 pm.
6.150	ZPI4	VILLARRICA, PARAGUAY, 48.75 m. 5-6 pm.
6.147	ZRD	DURBAN, SOUTH AFRICA, 48.8 m., Addr. (See ZRK, 9.606 mc.) Daily exc. Sat. 11.45 pm.-12.50 am.; Daily exc. Sun. 3.30-7.30 am., 9 am.-3.45 pm.; Sun. 5.30-7, 9-11.30 am., 12 n.-3.20 pm. Also 4-5 am., 3rd Sun. of month.
6.147	ZE8	BULAWAYO, RHODESIA, S. AFRICA, 48.8 m. Mon., Wed., and Fri. 1.15-3.15 pm.; Tues. 11 am.-12 n.; Thurs. 10 am.-12 n. Sun. 3.30-5 am.
6.145	HJ4ABE	MEDELLIN, COL., 48.79 m. La Voz de Antioquia. 11 am.-12 n., 6-10.30 pm.
6.140	W8XK	PITTSBURGH, PA., 48.86 m., Addr. Westinghouse Electric & Mfg. Co. Relays KDKA 11 pm.-12 m.
6.137	CR7AA	LAURENCO MARQUES, PORT. E. AFRICA, 48.87 m. Daily 12.05-1, 4.30-6.30, 9.30-11 am., 12.05-4 pm., Sun. 5-7 am., 10 am.-2 pm.
6.130	VP3BG	GEORGETOWN, BRIT. GUIANA, 48.94 m. From 5 pm. on.
6.130	COCD	HAVANA, CUBA, 48.94 m., Addr. Box 2294. Relays CMCD 7 am.-1 am.
6.130	VE9HX	HALIFAX, N. S., CAN., 48.94 m., Addr. P. O. Box 998. Mon.-Fri. 7 am.-11.15 pm., Sat. 11 am.-11 pm., Sun. 12 n.-11.15 pm. Relays CHNS.
6.130	LKL	JELOY, NORWAY, 48.94 m. 11 am.-6 pm.
6.125	CXA4	MONTEVIDEO, URUGUAY, 48.98 m., Addr. Radio Electrico de Montevideo., Mercedes 823. 10 am.-12 n., 2-8 pm.
6.122	HJ3ABX	BOGOTA, COL., 49 m., Addr. La Voz de Col., Apartado 26-65. 12 n.-2 pm., 5.30-11 pm.; Sun. 6-11 pm.
6.122	HP5H	PANAMA CITY, PAN., 49 m., Addr. Box 1045. 10 am.-1 pm., 5-11 pm.

(Continued on page 318)

All Schedules Eastern Standard Time



# Aerial Mast Made From a Ladder

● RECENTLY a picture appeared in a foreign radio magazine showing a novel antenna mast constructed from a ladder. An amateur version of such a ladder mast is shown in the accompanying pictures.

Fig. 1 shows an easy way to erect a mast made from a ladder of any desired length, in which the ladder is anchored against one end of a house. If the ladder is not very high, the extra guy ropes will probably not be necessary, the ladder being held against the building by means of two iron bolts, with their ends bent into a U-shape, as shown in the picture.

The great advantage of this ladder mast is that the experimenter can easily climb to the top of it in order to make changes in the antenna. Such changes occur quite frequently in the life of a radio experimenter. Hi!

Fig. 2 shows another type of ladder mast which is anchored "in the open" by means of guy ropes and cables. A word of caution is necessary if the builder intends to use wire cable for the guys—they should be broken up into short sections by means of insulators. Make sure that the length of any section is not a half or quarter of the wavelength being used by the station, or there will be considerable absorption of the energy in the guy wire sections. We also might mention that it is assumed the ladder, in any case, is to be made of wood.

Fig. 3 shows a strong mast made from two ladders, arranged in letter A fashion. A few guy ropes or cables are necessary to prevent side swaying of mast.

One method of erecting a fairly long ladder mast is shown in Fig. 4. A stubpole is erected at one side of the mast. By means of a rope and pulley (or block and fall) the ladder is pulled up into position, aided by several men pushing upward under the ladder, as shown in the picture. The guy ropes are all tied

Right—Several types of aerial masts which can be easily built around a ladder as a base. The principal feature is that the ladder enables the operator to change short wave aeriels easily.

(Continued on page 307)

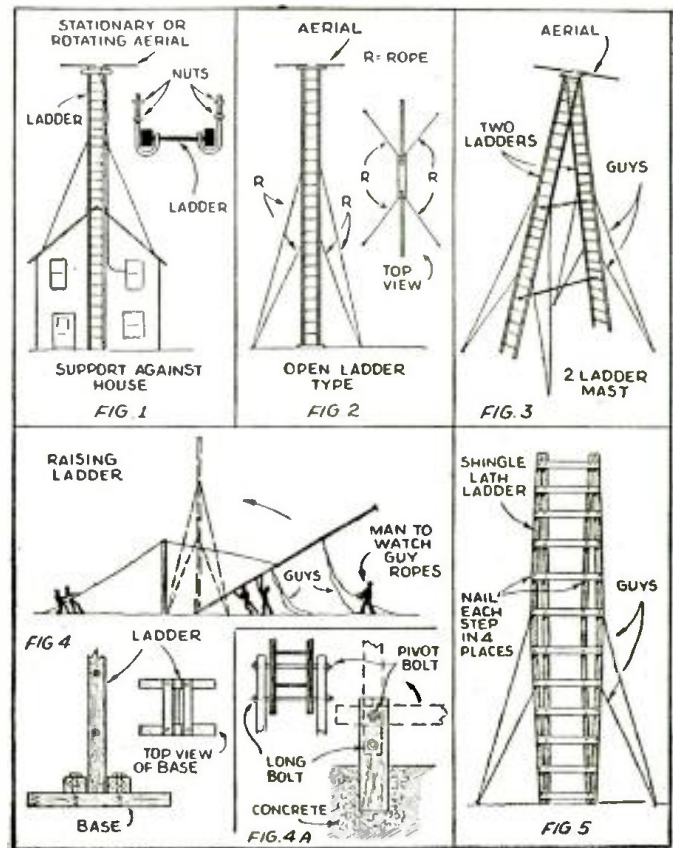

# Loop Antenna for 16 to 35 Meters

● HERewith are the construction details of an antenna which has shown such good qualities both here and at the "stations" of some of our SWL friends that we think it worthy of being passed on to others of our widespread fraternity. Primarily, it is designed to cover the frequencies between 16 and 35 meters, increasing the selectivity on the 16, 19, 25 and 31 meter sw broadcast bands together with the much overcrowded 20-meter amateur band, and acting successfully in the decreasing of static and over-all background noise. Its small size will not allow it to tune above the aforementioned frequency without the aid of a loading coil. Since the regular antenna covers the 49-meter band to our satisfaction, we dispensed with the loading coil and confined the loop to its resonant frequencies.

As can be seen from the accompanying diagram, the antenna is very easy to build, consisting of but a single loop of stranded, insulated, lead-in wire 50" long. However, it need not be insulated, nor lead-in wire, although stranded wire works somewhat better than solid. The twisted lead-in used here is four feet long, but tests have shown that the length is not critical. Needless to say, it should be as short as possible to avoid too much capacity in the tuning circuit and thereby prevent resonance over

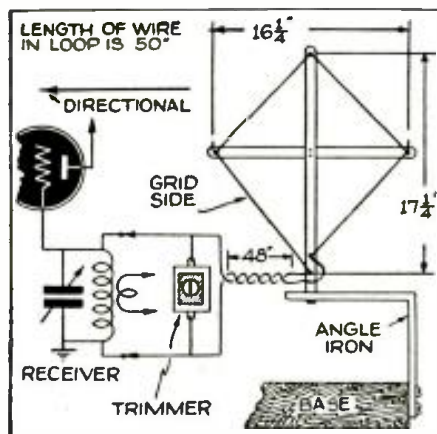

Here is a loop aerial for short-wave reception.

## Be Wise--

And order your October copy of RADIO & TELEVISION now. Yes, we said RADIO & TELEVISION, for that is the new name of SHORT WAVE & TELEVISION, beginning with the next issue.

(See announcement inside front cover.)

full coverage. A small trimmer condenser of the compression type is hooked across the loop at the receiver end to facilitate tuning of the loop.

To tune the loop: First, connect any length of wire to the receiver and tune in a weak station. Then without touching any of the controls, disconnect the wire and hook in the loop as shown in the diagram. Second, using an insulated screwdriver, vary the condenser across the loop until the signal is loudest. Once this condenser is set, it needs no further adjustment, unless coils are changed.

Concerning the directional qualities—greatest signal strength on weak signals was noted when the grid side of the loop was toward the station being received.

An unailing test for resonance is to grasp the grid side of the loop with the hand; if the loop is tuned properly, the signal will show a marked decrease in strength, whereas if it is not at resonance, grasping the loop will result in a slight increase. It is important that the loop resonate if optimum results are to be obtained.

This novel antenna has received many worthy compliments from SWL and ham visitors here at the "station" and several of them have built duplicates with gratifying results.—FRANK H. TOOKER.





A fee of 25c (stamps, coin or money order) is charged for letters that are answered by mail. This fee includes only hand-drawn schematics. We cannot furnish full-size working drawings or picture layouts. Letters not accompanied by 25c will be answered on this page. Questions involving considerable research will be quoted upon request. Names and addresses should be clearly printed on each letter.

### 3-Tube Superheterodyne Receiver

Please print a diagram of a superhet using a 2A7 as first detector, a single iron core I.F. stage with regeneration control using a 58 tube and a 55 as second detector, A.V.C. and first stage of audio. The set should use 4-prong coils covering 10 to 550 meters using 140 mmf. ganged tuning condensers and have an R meter in the A.V.C.—Jack Falato, Hackensack, N. J.

A. We have drawn a diagram employing regeneration in the I.F. stage. It will be necessary to add a third winding to the first I.F. transformer. This is the winding marked T. T may consist of

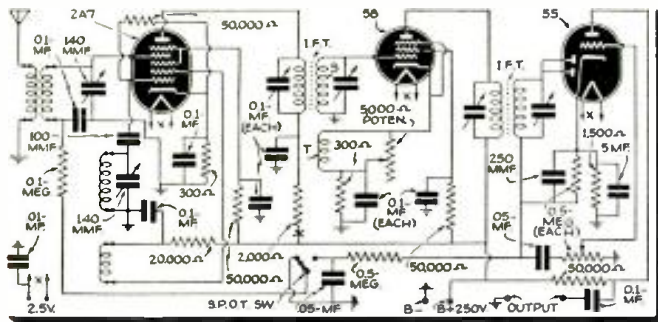

A 3-Tube Superhet Using 2.5 Volt Tubes—1150

about 100 turns of No. 26 D.S.C. wire wound on a 5/8" form mounted close to the winding S of the first I.F. transformer. Regeneration is controlled by a 5000 ohm potentiometer. The S.P.D.T. switch is used for turning the A.V.C. on or off, as desired.

The A.V.C. has been applied only to the 2A7 tube, as it is impractical to use it on the I.F. stage when regeneration is employed. For this reason, we doubt whether an R meter would be very effective in this receiver. However, a 0 to 15 ma. meter may be connected at point X for this purpose. Due to the limited A.V.C. action the meter will only deflect on fairly strong signals. In addition the reading of the meter will not be reliable as different settings of the regeneration control will result in different R readings on the meter. It would require an elaborate circuit using more tubes to get it to work properly.

**Due to space limits we cannot publish all diagrams requested. The editor selects those of greatest interest to all readers. If a diagram you requested has not been published, please bear this fact in mind.**

### Curing Genemotor Hash

I have a genemotor power supply which develops a nasty squeal in my 5-meter receiver and, to a lesser extent, in a broadcast receiver. What can I do to eliminate this noise?—Earl A. Raesly, Belvidere, N. J.

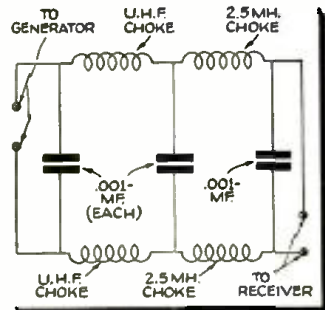

Curing Genemotor Noise—1151

extra filter system should preferably be mounted as close to the genemotor as possible. If the genemotor is mounted in a shielded container, it will aid matters considerably.

### Line Cord Connections

Most circuits for A.C.-D.C. receivers show a resistor-type line cord for supplying the heaters of the tubes of the receiver. Generally a diagram will show only two connections to a power cord, but a resistor line cord has three wires. Where does the third wire go and how is each of the wires connected into a circuit?—Louis Oberdoester, Allentown, Pa.

A. The schematic and pictorial sketches of a line cord, shown here, should clarify this problem for you. The resistor wire is usually covered with a white asbestos insulation and the end of it is tipped with an eyelet. The resistor wire is always connected in series with the heaters of the tubes in a receiver and the black wire is used as the common B- return lead. The power switch is usually placed in series with this black wire. The colored wire connects to the plate of the rectifier tube.

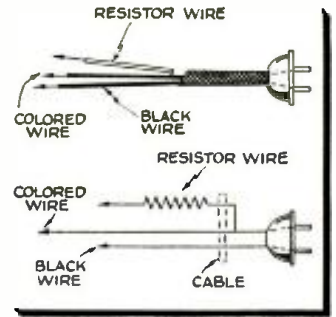

Resistor Line-Cord Connections—1152

### A 3-Tube T.R.F. Receiver

Will you please print the best circuit to use with the following tubes: A 77 as R.F. amplifier, a 6F7 as a detector and first A.F. amplifier, and a 12A7 as second A.F. amplifier and rectifier.—Gene DePalma, Flushing, N. Y.

A. The most satisfactory circuit for each of these tubes is shown. It makes use of 4-prong plug-in coils in the antenna stage and 6-prong plug-in coils in the detector stage. An A.C.-D.C. circuit is used in this receiver for simplicity's sake. Regeneration is controlled by a 50,000 ohm potentiometer on the 6F7 pentode. A headphone jack is also included in the plate circuit of the first A.F. amplifier. The output transformer for the loudspeaker should have a primary impedance of 13,000 ohms to properly match the 12A7 tube. Coil data for this receiver may be found on the Question Box page in the March, 1938, issue of SHORT WAVE & TELEVISION. With the amount of filtering shown in the power supply circuit little hum should be evident, even on the headphones. It is essential that the receiver chassis be ungrounded. It may be grounded through the 0.5 mf. condenser but not directly. If this is not done the line fuses in the house may be burned out.

A speaker field (3000 ohms) may be connected from cathode of the diode section of the 12A7 tube to chassis to provide proper excitation.

The two 140 mmf. tuning condensers may be ganged to simplify tuning. If this is done, however, a 15 mmf. trimmer condenser should be shunted across the antenna section.

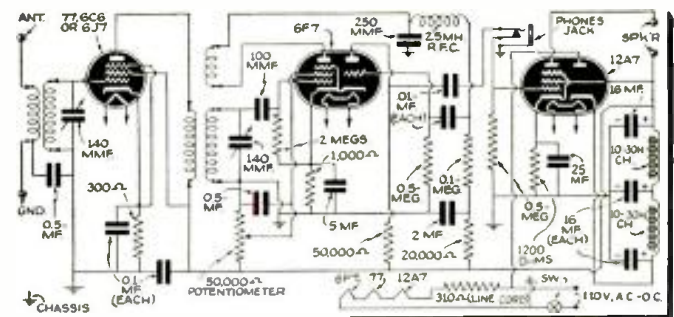

3-Tube A.C.-D.C. Dual-Purpose-Tube Set—1153

# New Short-Wave Apparatus

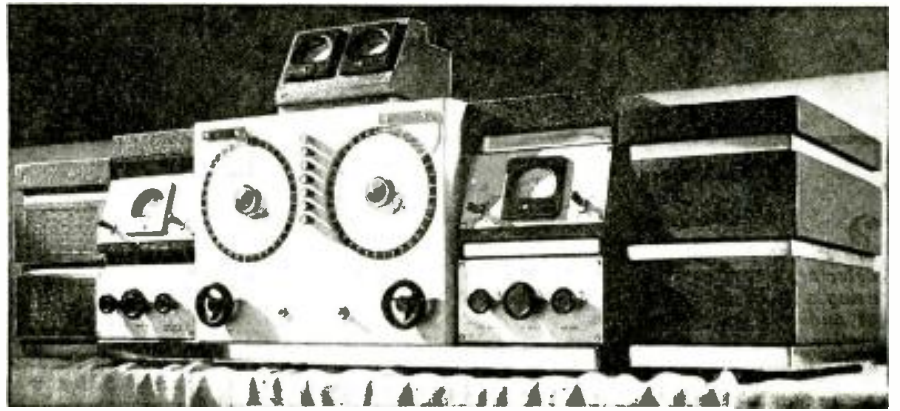

## Diversity Receiver for Hams

● DIVERSITY reception is not entirely new to radio engineers. Commercial radio stations have built diversity receiving systems at great expense, with striking im-

provements in the quality of short wave reception. Briefly, the advantages of diversity reception is in the practical elimination of fading effects, and a considerably higher average signal-to-noise ratio than can be obtained from any single receiver.

Diversity systems consist usually of individually tuned receivers, each connected to a separate antenna, the second detector outputs of which are tied together across a common load, and the signals combined after rectification, with the resulting audio output equalling the average of all receivers.

This type of diversity receiving system is satisfactory for commercial use where reception is mostly on a single frequency for hours at a time—but highly unsatisfactory for amateur communications work, when the individual tuning is entirely too complicated and time consuming to be practical.

The new Skyriders diversity offers diversity reception in practical form for amateur operation for the first time. It is a single control *dual diversity receiving system*, consisting of two complete R.F., I.F. and second detector circuits, with a common R.F. heterodyne oscillator, common A.V.C. and one audio amplifier. A block diagram showing the tube functions is shown.

The principal advantages of diversity reception as demonstrated by this new receiver are:

1. The reduction of fading to negligible proportions.
2. An increase of average signal strength over any single receiver.
3. Improvement of signal-to-noise ratio over any single receiver.
4. Reduction of heterodyne beat note interference.

(Continued on page 318)

Block diagram, showing the various tube functions.

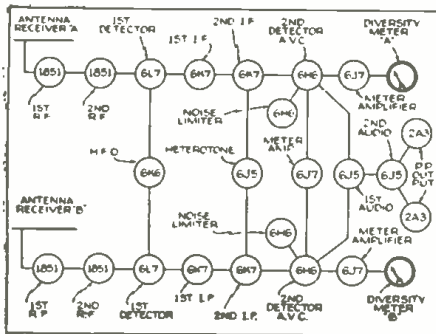

## New Items to Interest Fans and Hams

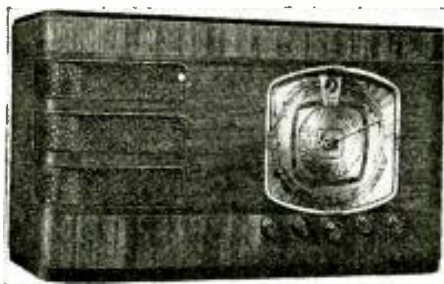

### 12-TUBE SUPERHET

● A NEW 4-band 12-tube superhet receiver has been announced by the Wholesale Radio Service Company. The receiver is available in both A.C. and A.C.-D.C. models and tunes from 13 to 130 meters and from 173 to 555 meters. In addition, a long-wave band for picking up European stations covers the range from 835 to 2050 meters. The receiver has a stage of r.f. preselection on all bands.

This article has been prepared from data supplied by courtesy of Wholesale Radio Service, Inc.

### RUBBER CONDENSERS

● PAPER condensers molded in live rubber jackets are the latest development of Aerovox. It is claimed that there is less absorption of moisture during the manufacturing process of this type of condenser

than with the ordinary molding process. In addition, there is no need for high pressures during the molding operation and the paper section does not alter its electrical characteristics. The units are available in capacities up to .25 mf., 200 volt rating; .1 mf., 400 volt rating; .05 mf., 600 volt rating and .01 in 1000 volt rating.

This article has been prepared from data supplied by courtesy of Aerovox Corporation.



### COIL-WINDER

● A PROFESSIONAL type coil-winder suitable for use by the amateur has recently been released in an improved model. The machine will take coil forms up to 7 inches in diameter and 7 inches in length. Fourteen different winding speeds are available to conform to different wire gauges. A revolution counter is also built into the unit.

This article has been prepared from data supplied by courtesy of Miami Laboratories, Inc.

### LOW-VOLTAGE C-R TUBE

● A NEW low-voltage cathode-ray tube of the high vacuum electrostatic deflection type has been announced by RCA. This tube (the 902) has a 2-inch fluorescent screen and will operate with voltages from 400 to 600 volts. It may be interchanged with the 913 C-R tube if the voltage supply is 400 volts or higher.

Giving a bright image at low voltages, the tube is especially suited for use in portable oscillographs.

This article has been prepared from data supplied by courtesy of RCA Manufacturing Co.



### "CAPACITOR" BOOK

● A NEW book entitled "Electrolytic Capacitors" has been published by Cornell-Dubilier containing reliable information on the theory, construction, characteristics and applications of electrolytic capacitors. It contains information valuable to all radio enthusiasts.

This article has been prepared from data supplied by courtesy of Cornell-Dubilier Electric Corporation.



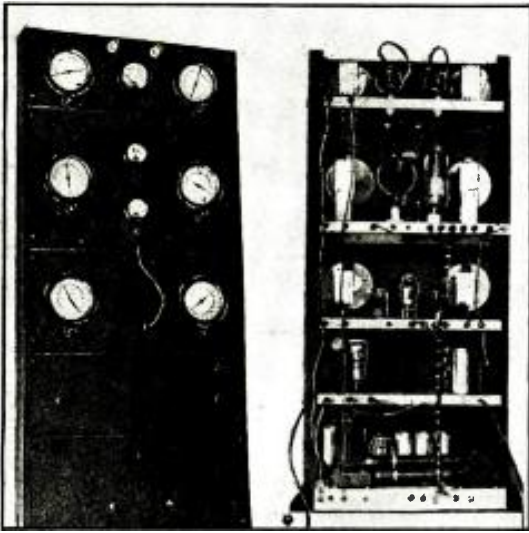

Front and rear views of transmitter.

# Suppressor-Grid Controlled C.W. and Phone

M. N. Beitman

The complete data for the coils for all bands can be obtained from any handbook. The special antenna coupling system is completely described in the handbooks and really does help to put the soup into the antenna.

The modulator uses a 57 as a triode, a 56, and a 2A5 pentode in the output stage. This arrangement gives plenty of gain for a crystal mike and has five watts audio output for suppressor modulation. This is a bit on the lean side and a push-pull output stage would help matters.

Now let us turn to the artistic and mechanical make-up of the rig. You will note that this is a real rack and panel job. All the variable condensers are controlled by illuminated airplane dials; switches controlling the power supply have indicating bull's eyes; and there are feeder insulators for the antenna connection.

(Continued on page 302)

Right — Diagram of transmitter, which is of simple design and construction.

● TO the ham, the other fellow's transmitter is always of interest. We are continually rebuilding or changing our rig and a hint or a helpful suggestion goes a long way in getting better results. While the transmitter described is quite conventional, it does have features and adaptations that mark it as a good all-around job for phone and c.w. work. By using several crystals and plug-in coils W9VAF claims to have worked some real dx. So let us give the rig the once over.

Beginning with the crystal oscillator and following right through to the power supply, we note economy as the keynote. An inexpensive type 59 tube served as an excellent oscillator and by means of the switch can be made to operate on the crystal's natural frequency or may be tuned to the second harmonic. Link coupling comes in handy since the oscillator and final are located on different decks. The 0-100 ma. meter is connected to a plug and may be used to measure either the oscillator plate current or the final tubes grid current.

The final stage uses a pair of RK-20's in push-pull; with 1250 volts on the plates you get c.w. input of 150 watts, phone input of 40 watts. Notice how the circuit constants are altered when the switch is changed from c.w. to phone transmission or back. For phone the suppressor grid has a negative C bias of 45 volts, while for c.w. the C bias is positive 45 volts.

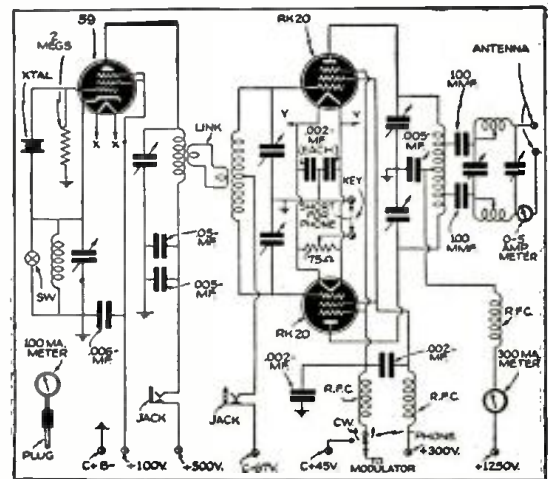

# A Cheap Voltage Doubler

● HERewith I give instructions for building a single-phase, half-wave voltage-doubler rectifier operating on the 115 volt A.C. lines without the use of a high-voltage transformer. The only transformers necessary being two center-tapped filament transformers reconstructed as described below. You can see readily that the circuit is not a new one, but I am sure that it will appeal to many short-wave enthusiasts who are limited financially and happen to have a couple of single-diodes lying around.

For small sets, whose over-all high-voltage drain is in the near vicinity of 30 milliamperes, the output voltage runs about 250 volts D.C. from 115 volts A.C. input. This milliamperage will very easily accommodate any of the 2 and 3 tube sets built by the amateur experimenter; even being sufficient to drive a small power tube included in the circuit. There is no doubt in my mind but that this is the cheapest high-voltage supply which can be built, considering the output that is obtainable. It is also universal—as the circuit is equally adaptable to both the 25Z5 double-diode, or to two single-diodes of the 81 type.

Concerning the transformers that are needed for the filament supply: there is no reason why anyone cannot rewind a couple of cheap bell transformers to the needed specifications and with satisfactory results. It is only necessary to remove the original secondary winding and replace it with

heavier wire to the proper voltage by the cut-and-try method, or if an A.C. voltmeter is at hand, so much the better. The winding is then taken off again, counting the number of turns so that the center-tap can be accurately placed.

Concerning the circuit diagram: V1 and V2 are single-diode tubes of the 81 type; T1 and T2 are the filament transformers made to the above simple specifications; C1 and C2 are electrolytic condensers with a capacity of 16 mf. each. It is important that these condensers be as large as possible, as they must carry the total voltage obtainable at the output of the rectifier. It is equally important to note that a dual condenser cannot be used at this point if the two condensers incorporated have a common ground, as they must be wired into the circuit as shown in the diagram. C3 and C4 are condensers commonly used in rectifier filter circuits and have a value of 6 to 8 mf. each; L1 and L2 are the iron-core power choke inductances of 30 henries each. The lower the resistance of these two units the higher will be the D.C. output. This rectifier was successfully built and tested by the author.—FRANK H. TOOKER.

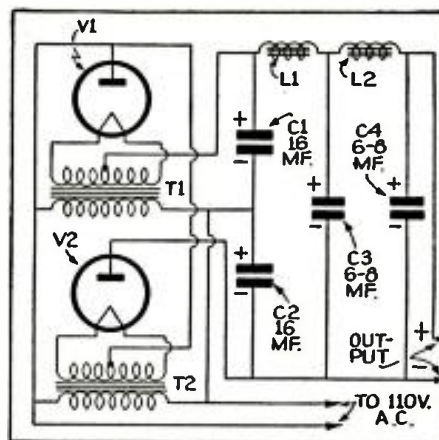

Simple circuit for Voltage Doubler.



# Build This "5 in 4" All-Wave

This receiver is of reasonable first cost and operates on 110 volts, A.C. By the use of modern tubes, four tubes do the work of five. Plug-in coils are used and the set operates a loud-speaker.

ings show, built up on a the specified cabinet. The various controls on the front, left to right, are as follows: Regeneration control, tuning dial, audio volume control and, at the upper right of

Here's the "5-in-4" receiver "under test."

● EVER since the early days when broadcast radio was in its swaddling clothes, the three- or four-tube circuit using a tuned-radio-frequency stage, a regenerative detector and one or two stages of audio has been a popular and highly efficient type of receiver. After the advent of the screen-grid, pentode and duo-triode tubes, the circuit was still further improved until today the "t.r.f." set of modern design is, beyond a doubt, the best for the beginner ham or fan who wishes to avoid the intricacies of building and adjusting a good superheterodyne.

### Ideal Set for Beginner

The 4-tube t.r.f. receiver to be described here is designed especially for the experimenter who has had little or no experience in radio construction. The circuit has been kept as simple and straightforward as possible and only easy-to-get parts of standard manufacture have been used throughout. Plug-in coils simplify the band-changing problem and give a flexibility obtainable by no other method. A detachable shield covers the r.f. coil, eliminating shielding difficulties and presenting a more finished appearance to the chassis.

The schematic diagram, fig. 1, shows the circuit which consists of a 6S7G as tuned-radio-frequency stage, a 6F8G as a combination regenerative detector and first audio and a 6F6G as pentode output tube; the rectifier is a 5U4G. With the exception of the 6F6G, all of the above tubes are of rather recent release, the 6S7G being a new r.f. and i.f. pentode similar to the 6K7 but having a heater drain of only 0.15 amperes; the 6F8G is a new dual-triode having two separate cathodes. This tube was featured by W2AMN on page 686 of the April number. The 5U4G is similar in characteristics to the older 5Z3 and is certain to find a wide application in both short wave receivers and transmitters. All of the tubes are of the new standard octal-base type.

Vernier Dial Gives Razor-Sharp Tuning  
The set is, as the photographs and draw-

Even the beginner in short-wave set building will find it easy to follow the diagrams given below.

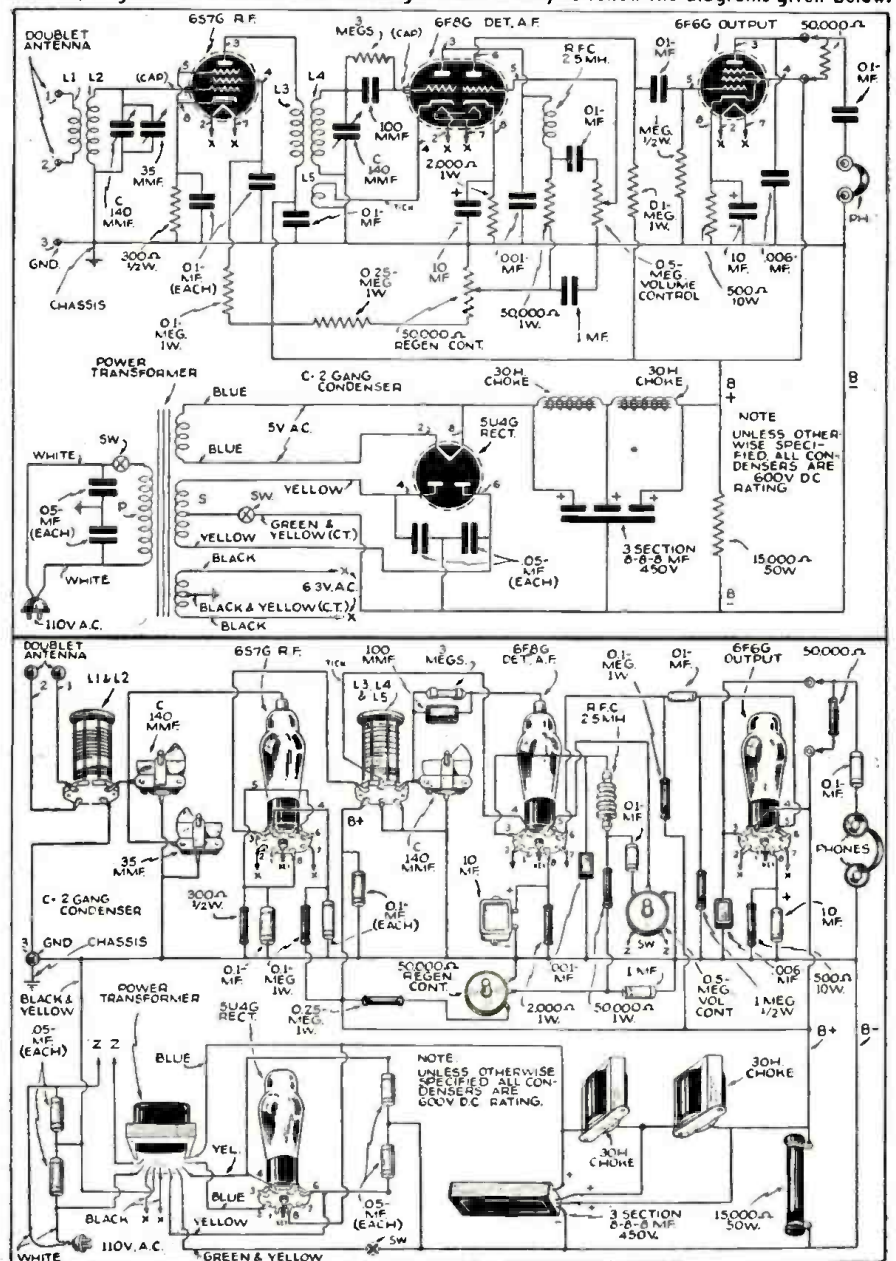



# T. R. F. Receiver

Harry D. Hooton, W8KPX

The rear view of the receiver, reproduced at the right, shows the very neat arrangement of the parts. Note the shielded R.F. coupling coil at the left center.

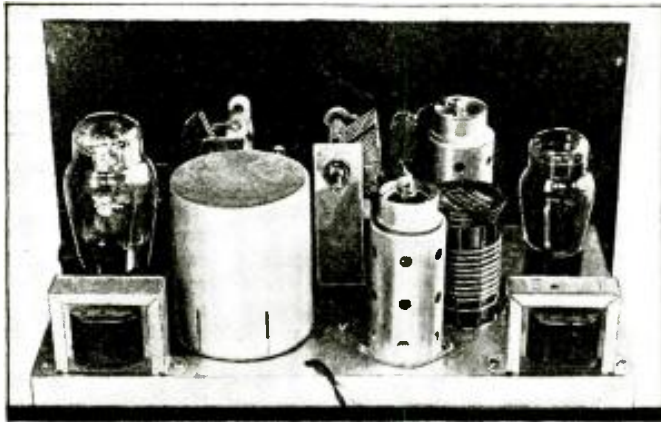

the dial, the 35 mmf. r.f. trimmer condenser. The airplane dial used on this receiver is rather interesting, inasmuch as it mounts directly on the front of the panel, no larger circular cut-out being required. The dial ratios of 30:1 and 165:1 permit actual *razor-edge* adjustments on any signal no matter how weak or long distant it may be.

The actual construction of the receiver is not at all difficult but in order to do a good job the work should be done slowly and carefully. Lay out the various lines on the chassis and panel as shown in Fig. 2. Draw out the outlines of the socket holes and the transformer cut-out with a sharp-pointed instrument such as a scriber; never use an ordinary lead pencil for this purpose as the sharp point will wear away, giving rise to inaccuracies. Drill and cut *all* of the holes before mounting any of the parts; metal dust or filings, once imbedded in the isolantite insulation of the sockets and tuning condensers, is almost impossible to remove and is certain to cause heavy r.f.

losses if not an actual short-circuit. Make certain that the holes for the coil sockets are large enough to permit the coils to be changed without having the prongs come in contact with the metal chassis. All burrs and sharp points of metal should be removed with a file and steel wool or sandpaper before the parts are mounted.

### Keep Leads Short!

Keep the wiring, especially the "hot" leads from the grids and plates of the 6S7G and 6F8G tubes to the coil sockets and tuning condensers, as *short* and *direct* as possible. Use a clean, hot and well-tinned iron and rosin-core solder and *sweat* each joint thoroughly to insure a good connection. Avoid the use of metal clips and lugs; these are unsatisfactory soon after the surface becomes oxidized and oxidation starts the moment that copper comes in contact with the atmosphere. It is not necessary to keep the audio and power wiring leads as short as that of the r.f. portion,

(Continued on page 303)

The bottom view of the receiver discloses no unusual amount of intricate construction, and the set can be built by practically any one after a careful study of the text and diagram.

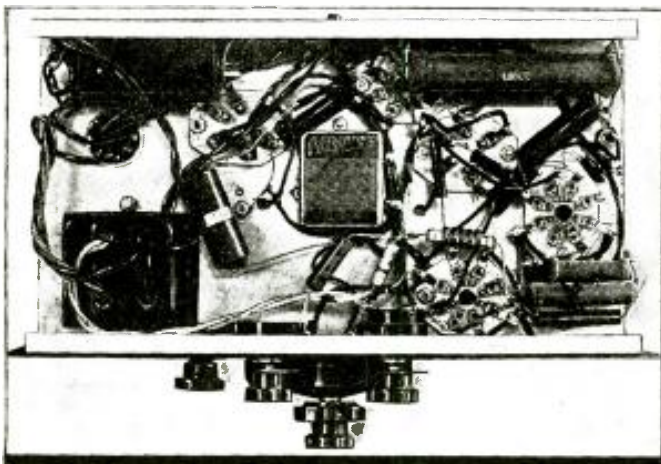

## FREE-Allied's 1939 RADIO CATALOG

180 PAGES! JUST OUT!

EVERYTHING IN RADIO  
at Lowest Prices!



**NEW SETS!**  
62 amazing 1939 KNIGHT Radios—as low as \$7.95! 4 16 tubes—new "Teeny-Weenys," low-drain battery sets (1.5 tubes) record players, phonographs, photo-radios!



**NEW SOUND!**  
Complete range of new P.A.—8-65 watts. New Portable systems, 30 watt Mobile System, Boosted Power 3 tube, Electric Guitar Amplifier,—and a complete line of recording equipment.



**NEW PARTS—KITS!**  
More than 14,000 parts! New Build-Your-Own kits: Beginners' 1, 2, and 3 tubes, 6 tube auto radio, Photo Cell, Electric Fence, 4 Tube Portable, low-cost transmitters, etc.—and diagrams and projects for building 100 kits!



**NEW HAM GEAR!**  
A new Giant Ham section! New Hamcrafters ship-to-shore, National, Ham-mart, Utah, and GTC marlunds as low as \$15.95; new receivers: National NC-510 and NC-44; Hamcrafters "Dual Diversity" and "Marine"; Sargent "Streamliner"; Howard, etc.



**NEW TESTERS!**  
All leading lines! New Push-Button type equipment, Rider's Channelyst—Tube Checkers, Set Testers, Analyzers, Oscilloscopes, Meters—and over 14,000 parts!

Fastest Service,  
Highest Quality,  
Lowest Prices!  
Write for ALLIED's  
new 1939 Catalog!

Free!  
SEND COUPON



Allied Radio Corporation,  
Dept. 3-J-9  
833 W. Jackson Blvd.,  
Chicago, Ill.

Send me your new FREE 1939 catalogue.

Name .....

Address .....

City ..... State .....

ALLIED RADIO CORP.

# A Beat-Frequency Oscil-

## It Helps to Locate Those Weak DX Stations

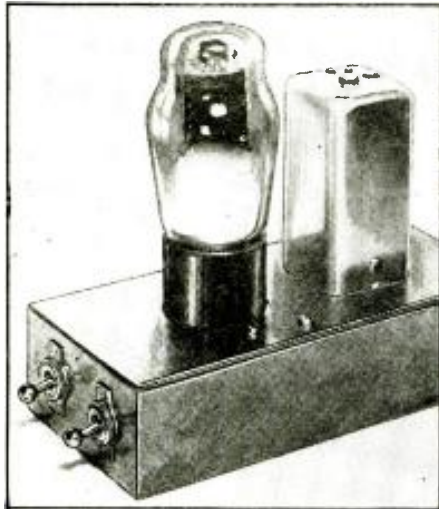

The complete beat-frequency oscillator.

● THE widespread use of *all-wave* receivers has resulted in a large number of their users becoming enthusiastic short-wave listeners. Hunting for faint dx signals requires not only a certain amount of skill, but is greatly facilitated by the use of proper auxiliary equipment. When tuning a receiver, the louder stations are readily heard because of their greater signal

strength. The weaker stations, generally the better "catches," are barely perceptible. This is especially true when turning the dial rapidly. If, as is quite often the case, the station merely has its carrier on the air, with no signal modulating it, the listener will be unaware of its presence. Foreign stations have not the same regard for split-second timing of programs that American stations have, so that between programs and even during programs there are frequent gaps during which the carrier is unmodulated.

A device that will indicate the presence of a carrier, even though unmodulated, therefore, becomes an extremely useful gadget for the short-wave receiver. For use in superheterodyne receivers such a gadget is a *beat-frequency oscillator*. It is incorporated in all communication receivers, but unfortunately is found in practically none of the short-wave supers used for short-wave broadcast reception. A beat-frequency oscillator can be built into an existing receiver, but since most set owners dislike the thought of diving into a complicated receiver to make the necessary additions, a separate self-contained unit is desirable. Thus no changes are necessary to the receiver proper.

### How the Device Works

Before going into the description of the

beat-frequency oscillator constructed by the writer, it might be well to briefly state the principles of its operation. The tremendously high frequencies encountered in the intermediate amplifier of a superhet are generally in the order of 456,000 cycles per second. Since the human ear usually responds to a maximum of about 20,000 cycles, it would be impossible for one to hear such frequencies. When the carrier frequency is modulated by speech or music, it is the variations in carrier strength that are intelligible to the ear. But when the carrier is unmodulated, the difficulty in recognizing the signal is evident. If the output of a local oscillator is mixed with the signal, the two signals will interact to give the phenomena of "beats"; that is, a third signal will result, whose frequency is the difference in frequency between the incoming signal and the locally generated signal. The radio enthusiast is probably aware that the same phenomena occurs in the input circuit or first detector of the superhet, where a variable high frequency oscillator beats with the incoming signal to produce a fixed frequency intermediate frequency, which is then amplified by the intermediate frequency amplifier, before being detected for the second and final time. The local fixed frequency to beat with the intermediate frequency is generated by the beat-frequency oscillator. By mak-

Diagram for the beat oscillator.

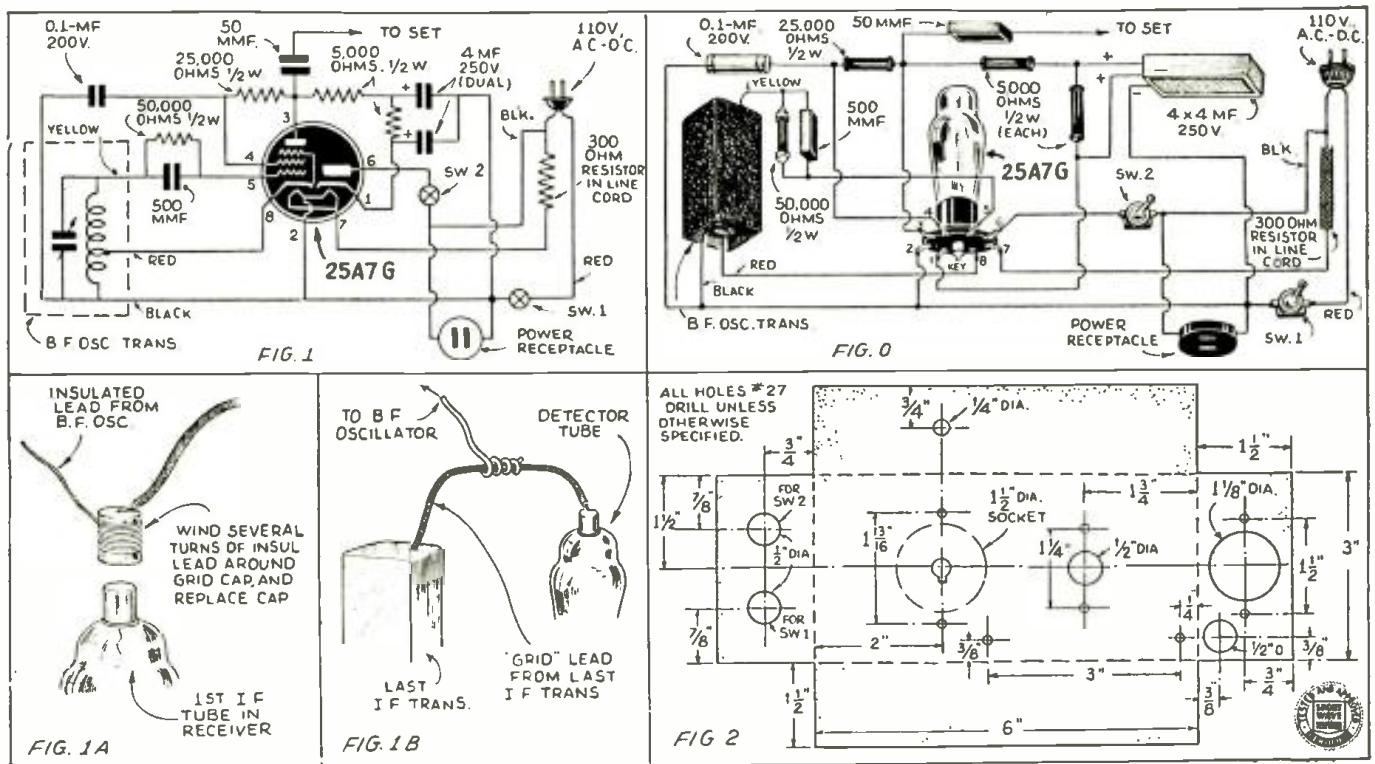



# lator

Herman Yellin, W2AJL

ing the beat oscillator frequency about one kc. different from the i.f. frequency, the beat frequency of one kc. (1000 cycles) will be a high-pitched whistle, pleasing to the ear and easily recognizable. Thus weak stations can easily be picked up merely by listening for the high-pitched whistle. When the whistle is heard, the beat-frequency oscillator is turned off — and there is your station.

### B.F.O. Brings in Code, Too

When listening to c.w. (code) stations the beat-freq. oscillator is an absolute necessity, since without it the code signals could not be heard. A beat-freq. oscillator is thus seen to have two uses. Not only is the reception of weak phone stations facilitated by its use, but one can eavesdrop on the amateur bands. The swl. desirous of learning the code may take his choice of any one of a number of slow-sending code stations. Incidentally there are a number of amateur stations sending code lessons on regular schedules.

In adding a beat-freq. oscillator to a superhet, it is often undesirable to impose any additional drain on the power-supply of the receiver. Many broadcast short-wave receivers are unable to furnish the additional power, slight as it is. Frequently the additional drain on the power-supply will throw the receiver off its calibration. The

## OUR NEW SHORT WAVE LISTENER MODEL THE DOERLE MODEL D39

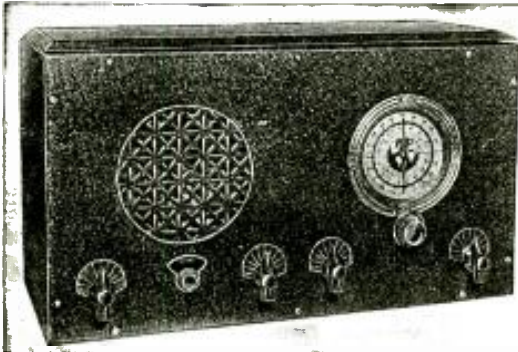

### THE OUTSTANDING VALUE FOR 1939

Model D39 designed to have all the desirable features of our larger models but at a price within reach of all.

Uses a 6k7g tube as screen grid tuned R.F. amplifier, a 6j7g tube as tuned electron coupled screen grid regenerative detector, a 76g tube as a driver audio which is fed into the popular and efficient 2516g beam power audio output tube which delivers over two watts of undistorted audio power to the dynamic speaker.

A 25z6g tube is used as the rectifier and is fully capable of supplying the power requirements of the set. A type k92a tube is used as the ballast to drop the filament supply to the proper voltage. Separate controls for volume, tone, regeneration and R.F. gain are used.

A headphone jack is incorporated to permit the use of phones when desired which automatically cuts off the speaker when phones are plugged in.

A carefully designed circuit is used so as to give maximum efficiency and output. The built-in power supply is well filtered to eliminate hum. Filter networks are incorporated in the audio amplifiers and a tuneable hum filter removes all traces of this condition common in many short wave sets. Operates from regular 110 volt house current. Covers from 9 to 600 meters with no skips which includes the standard broadcast band and all short wave bands except the amateur 5 meter band. Send stamp for circular D39.

Sold complete ready to use nothing else to buy with all tubes and coils 9 to 600 meters wired and tested . . . . .

All parts needed to build and wire but less tubes, with all coils, cabinet, chassis and diagram. May be obtained in battery model or 220 volt model at same prices for portable or foreign use.

**\$19<sup>95</sup>**

**\$14<sup>95</sup>**

**FLASH!** SEND 10¢ FOR OUR NEW CATALOG containing CIRCUIT DIAGRAMS, and complete information on over 25 different types of short wave receivers and transmitters from \$2.50 and up. This catalog is chock full of schematic and picture diagrams, book ups and short wave information. A book in itself. Well worth the dime, which will be refunded with your first order.

**OSCAR B. KUSTERMAN** 68 Barclay Street, Dept. 9  
New York City

are cut from the corners and sides of the chassis bent as shown by the dashed lines. All holes and their sizes are clearly shown on the drawing. The hole for the tube

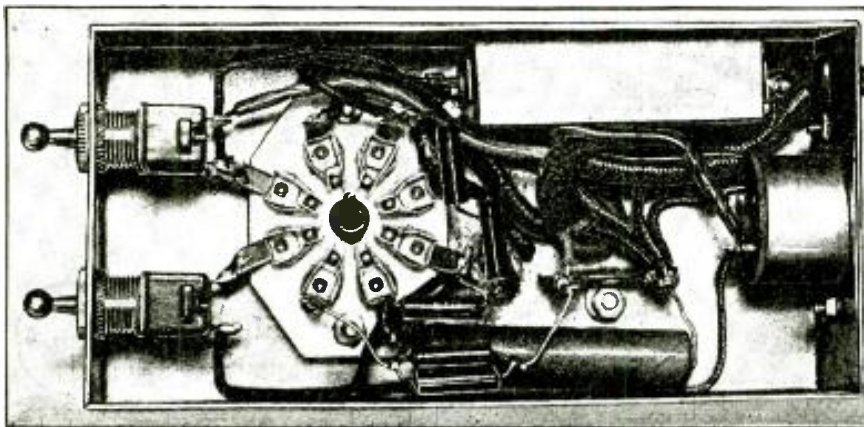

Bottom view of the oscillator.

present design of beat-freq. oscillator therefore has its own built-in power supply, operative on either a.c. or d.c. Rather than use separate tubes for the oscillator and rectifier, one of the newer dual-purpose tubes was employed. This tube is the 25A7G, an octal base tube having in one envelope a pentode section and a diode rectifier section. The two sections are entirely separate, having individual cathodes. A 300 ohm resistor built into the line cord drops the 110 volts to 25 volts. The chassis can be made from a piece of sheet metal 6" x 9", 1½" square pieces

socket should be made large enough for the tube base to fit through. This is done so that there will be no gap between the socket and the bottom of the tube base. A gap will prevent the tube from making adequate contact with the socket springs.

It will be noticed that a 110 volt outlet has been provided on the rear of the chassis. This enables the user to plug his short-wave receiver into the beat-freq. oscillator unit and thereafter turn on the "wfo" and the receiver at the same time SW-1 on the "wfo" unit controls the line  
(Continued on page 309)



## TRANSOIL

for transmitting

HIGHEST QUALITY OIL CAPACITORS

Ask for new complete Transmitting Catalog describing

TRANSOIL—SOLAR—TRANSMICA

SOLAR MFG. CORP.  599 BROADWAY, NEW YORK CITY



## HAMS—FANS!

The 1938 edition of the famous Hammarlund SHORT WAVE MANUAL is chock full of high and ultra-high frequency receivers and transmitters. No ham or experimenter can afford to be without a copy.

Send 10¢ for your copy now!

HAMMARLUND MFG. CO., Inc.  
424 W. 33rd St., N. Y. C. Dept. SWT-9.

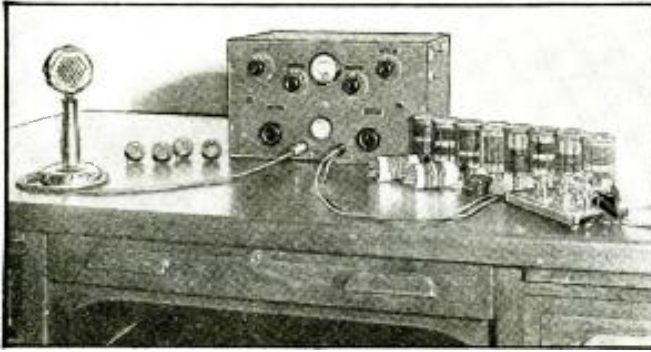

The complete portable transmitter with "mike" and wave-change coils.

# Portable

This phone transmitter operates on 160, 80, 40, 20 and 10 meters. Coil data is given for all these bands. The construction cost is nominal. Band-change made in 30 seconds.

● THE object kept in mind when contemplating construction of this portable transmitter, was to incorporate enough power output on all bands to enable one to compete with the present day QRM, and still keep the physical size within portable limits.

The metal cabinet measures 8 by 10 by 14 inches. The power output is between 25 and 30 watts on all bands. Band-changing can be accomplished in about 30 seconds. The inductive coupling between stages minimizes the number of tuning controls, but still delivers ample excitation to the final amplifier. All r.f. current readings are accomplished with the meter selector switch, thereby eliminating bulky jacks and plugs or additional meters. All tun-

ing adjustments are brought through the front panel with the exception of the oscillator condenser, which is mounted within the oscillator coil form. The crystal plugs in from the front for additional convenience.

### Construction Details

Care should be exercised to properly shield the complete *speech amplifier* and to shield the *final amplifier* from the preceding stages, as shown in the photographs. The microphone jack shield contains the bias cell, coupling condenser, and grid resistor for the first triode of the 79 tube. The tube itself is completely shielded both below and above the chassis. A large size shield can is cut off in order to make a

shield can for the gain control. The leads to the gain control and from the microphone jack to the grid of the 79 (first triode) are also shielded. The 79, 5Z3, and both RK-39's are mounted below the chassis about one inch.

A number of meter selector switches were tried until the present one was employed. The first type used was of the receiving type and would arc over occasionally. The present switch is of the band-switching type and has a 1,000 volt spacing between contacts. However, if it is desired to take the readings in the cathode instead of the plate leads one of the smaller type would be quite satisfactory. The windings of the power transformer, modulation and filter chokes oppose each other in order

Wiring diagram of 30-watt portable transmitter.

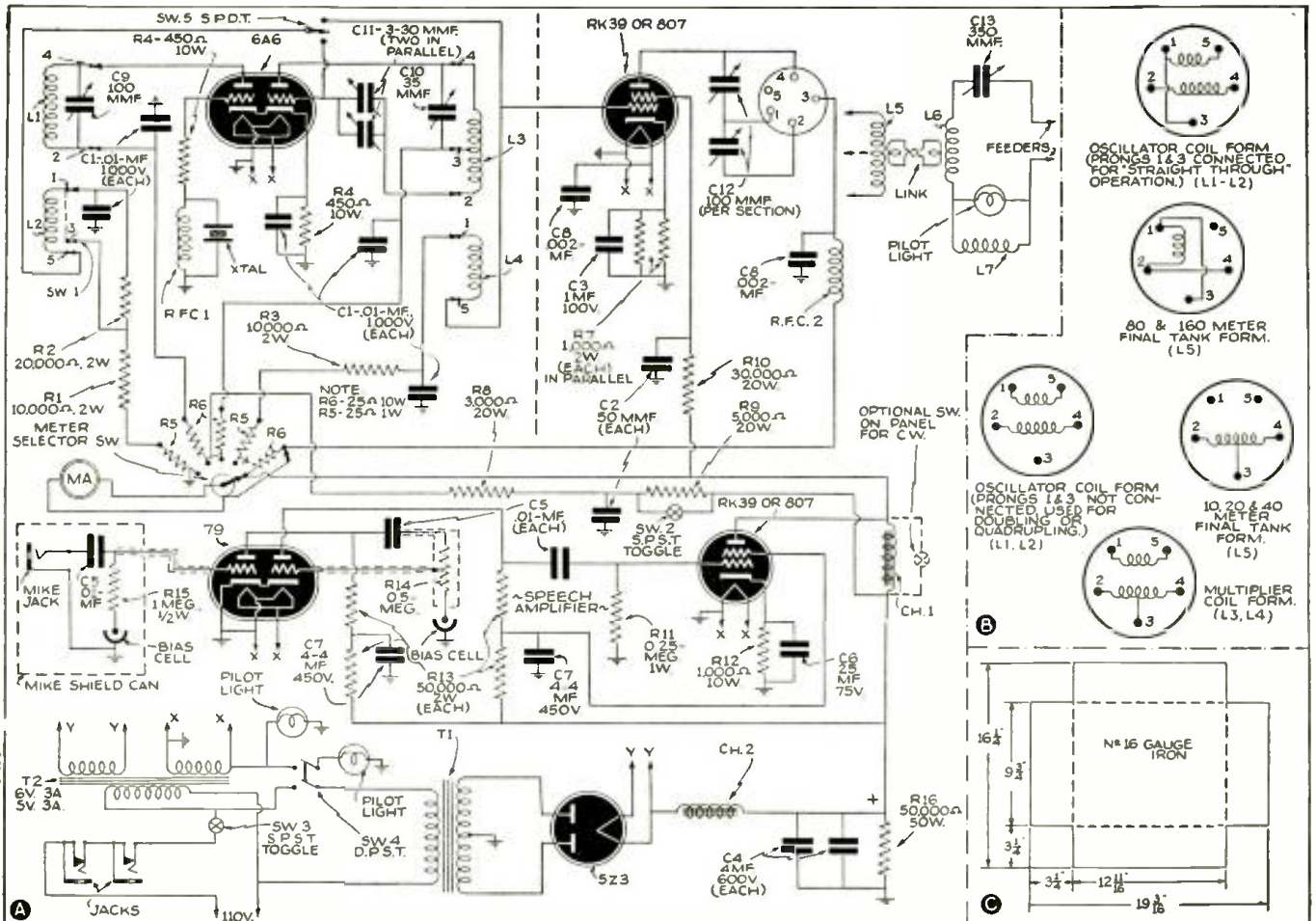



# 30-Watt Xmitter

J. E. Striker, W6MOV, W6OPG

Top view of transmitter, removed from its metal case.

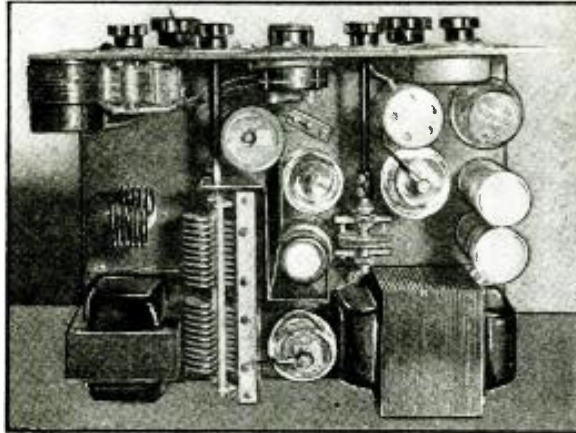

to eliminate the possibility of induced hum.

Switch No. 1 is merely a connection between prongs No. 1 and No. 3 on the 160 and 80 meter oscillator coil forms. When switch No. 5 is in the *up* position the bias resistor R1 is in the grid circuit of the RK-39. When the switch is in the *down* position R3 is then the bias resistor for the RK-39. To enable the final amplifier to have the correct bias at each position, a portion of the resistance R2 is shorted out by this means. If this particular arrangement is not done the final amplifier will be excessively biased when the R.F. section is operating *straight through*. However, when it is desired to *double* in the low frequencies, such as from 160 meters to 80 meters, the connection can be left on the coil form. There is no lack of excitation on any of the bands, due to the fact that the beam type tube seems to be dependent upon voltage and current for maximum efficiency, rather than drive to the grid. 2 ma. is all that is necessary to drive the beam tube to full output, but when it is used as a modulated amplifier it is best to have about 4 or 5 ma.

The communication switch is preceded by the filament switch, so that it would be impossible to apply the plate voltage without the filaments being turned on.

To accomplish the most necessary item in a phone transmitter (correct L-C ratio) an automatic switching arrangement is incorporated within the final tank coil forms. As can be seen in figure No. B, the 10, 20 and 40 meter coils are wound between

prongs No. 2 and No. 4, with the center tap connected to prong No. 3. The 80 and 160 meter coils are wound between prongs No. 1 and No. 2. Prongs No. 1 and 3 are connected together as are prongs No. 2 and 4. One stator of the final tank condenser is connected to prong No. 2 of the final tank coil socket, while the other stator is connected to prong No. 4. The rotor is connected to the socket prong No. 1. The 80 and 160 meter coils are not center-tapped as are the 10, 20 and 40 meter coils. Greater output was obtained by center-tapping the 10, 20 and 40 meter coils and by end-feeding the 80 and 160 meter coils. Through this system there is no compromise on any band as far as "Q" is concerned. When the 160 or 80 meter coil is inserted, there is an available 200 mmf. as the two sections are placed in parallel. When using the 40, 20 and 10 meter coils the final tank condenser is then in split-stator or series position with maximum capacity of 50 mmf. and minimum capacity of 6.5 mmf.

The pilot light in the center of the front panel is in series with the antenna circuit and is used as a modulation and tuning indicator. To keep the light from burning out, it is necessary to shunt it with about 12 turns of No. 20 wire on a form approximately 1/4 inch in diameter. A 6.3 volt light is used. The pilot light on the right side of the panel is the filament indicator. The one on the left side operates simultaneously with the communication switch (SW. No. 4). SW. No. 2 is mounted on the rear of the chassis. Two jacks (closed-circuit type) are used. One in the front of the panel and one in the rear. These are connected in series with the SW. No. 4. The one in front is used to insert the key while the one in the rear can be used for a remote control. Keying the primary in this manner worked quite well when using one of the better crystals. There was no chirp noticeable whatsoever. If, however, it is desired to key faster than 20 words per minute it

(Continued on page 301)

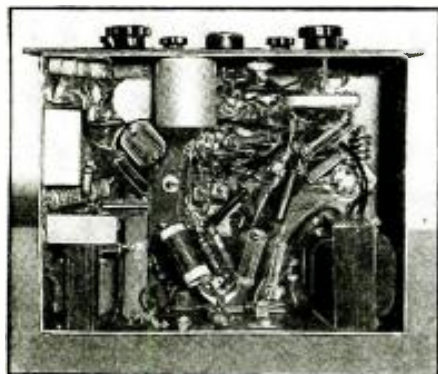

Bottom view of transmitter.

## GREATEST BARGAIN

in 10 years



as little as

Remington  
NOISELESS  
Portable  
NOW AS LITTLE AS  
10c a day

10c  
A  
DAY

Imagine a typewriter that speaks in a whisper! You can write in a library, a sick room, a Pullman berth, without disturbing others. And superb performance that literally makes words flow from the machine. The Remington Noiseless Portable is equipped with all attachments that make for complete writing equipment—it manifolds and cuts stencils perfectly. Furnished in black with chromium fittings.

### SPECIFICATIONS

Standard keyboard. Takes paper 9.5 inches wide. Standard size, 12 yard ribbon. Makes up to 7 legible carbons. Back spacer. Paper fingers. Roller type. Black key cards with white letters. Double shift key and shift lock. Right and left carriage release. Right and left cylinder knobs. Large cushion rubber feet. Single or double space adjustment. A brand new NOISELESS typewriter, right off the assembly line.

### 10-DAY FREE TRIAL

For the first time in history you can own a genuine Remington Noiseless Portable for as little as 10c a day or \$3.00 a month. Think of it! The finest Remington Portable ever built at the lowest terms we have ever offered.

And you don't risk a penny! We will send this brand new Remington Noiseless Portable for a **TEN DAYS' FREE TRIAL!** If you are not satisfied, send it back. We pay all shipping charges.

### FREE - TYPING COURSE

With your Remington Noiseless Portable—absolutely free—a 19-page course in typing teaching you the Touch System, always used by experts. With the help of this course you will find typing the most enjoyable way you ever wrote.



### SPECIAL - CARRYING CASE

Carrying Case, handsomely covered in DuPont fabric is included with your purchase. The case makes it easy to take your machine anywhere. You can use it on trains, or on your knees at home. Don't delay. Mail the coupon.



### MAIL NOW

Remington Rand Inc. Dept. 300-9  
465 Washington St., Buffalo, N. Y.

Tell me, without obligation, how to get a Free Trial of a new Remington Noiseless Portable, including Carrying Case and Free Typing Course for as little as 10c a day Send Catalog.

Name .....  
Address .....  
City ..... State .....



## RADIO INSTRUCTION

### WANT CODE SPEED? ASK CANDLER!

Candler methods are so easy, so interesting! You will be amazed at your progress with Candler instruction. You, too, can have the same training that made T. R. McElroy World's Champion. Remember there is only one Candler System. It saves you months of hard, tiring practice. You will make better progress with a few weeks of Candler training than you will in months of undirected practice. Start now! Learn all the necessary code fundamentals. Candler shows you the short cut to professional speed. You can find out how for a postage stamp.



**FREE!** Candler's book of facts. Check full of interesting data on code. Write for it today—it's free!

**CANDLER SYSTEM CO.**  
Dept. 59 Asheville, North Carolina, U. S. A.

Just Published . . . a **NEW RADIO AND ELECTRONIC DICTIONARY** Containing **3,800 Definitions** . . . . .

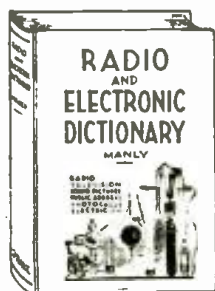

**THIS RADIO AND ELECTRONIC DICTIONARY**, written by Harold P. Manly, explains the meaning of 3,800 words used in radio, electronics and other closely allied fields. It includes new terms used in radio transmission, sound pictures, television, public address, aviation radio, navigation and industrial control, photo-electricity, photocell application, telephotography, etc. This dictionary permits learning every new expression whether you hear it or read it. Alphabetically arranged for quick reference. 550 illustrations augment definitions in the text.

The book is recommended for students, instructors, engineers, service men, experimenters, salesmen and everyone in any way associated with radio. **ONLY \$2.50** in U. S. A. POSTPAID. . . . Price

**HOOF OF ITS KIND—HANDY—EASY TO USE—AND TIMELY.** The **RADIO AND ELECTRONIC DICTIONARY** is new, authentic and printed in a single volume of 300 pages, size 6 x 9 inches. The book weighs two pounds, and bound in durable cloth. **SHIPPED ANYWHERE \$2.50** IN U. S. A. POSTPAID. . . . Price

Mail remittance by check or money order to  
**RADIO PUBLICATIONS**  
89-HUDSON STREET NEW YORK, N. Y.

## LEARN CODE RIGHT

It's easy and practical to learn or improve your radio or Morse Code, any speed. Senior model with 10 tapes and Book of Instructions—\$20.25. (Rented at low cost.) Junior model with 5 tapes and Book of Instructions—\$12.00. (Not rented.) Complete oscillator equipment, less batteries, \$6.50. Send for details today to—



**INSTRUCTOGRAPH CO.**  
Dept. SW-9  
812 Lakeside Place, Chicago

BUY ON CASH OR TERMS: HALLICRAFTER AND R.M.E. SHORT-WAVE RECEIVERS, SPEED-X and VIBROPLEXES

## RADIO ENGINEERING

broadcasting, aviation and police radio, servicing, marine radio telegraphy and telephony, Morse telegraphy and railway accounting taught thoroughly. Engineering course of nine months' duration equivalent to three years of college radio work. All expenses low. Catalog free. School established 1874.  
**Dodge's Institute, Turner St., Valparaiso, Ind.**

## Home S-W Diathermy Apparatus

● THE accompanying picture shows one of the latest types of home short wave diathermy apparatus. The picture shows the two electron pads placed in their proper position for application to the chest. The apparatus shown is especially intended for operation at home by the average person. The weight is about 40 lbs. The cabinet stands 21" high x 14" wide and 11" in depth. The deep heat therapy produced by these short wave diathermy machines is effective in the relief of many human ailments; with the machine illustrated, actual tests have shown that a very strong heat effect can be produced in the hand, foot, leg or arm within a few minutes.

The difference between the modern short wave diathermy apparatus and the older type of diathermy machine lies in the fact that in the new system, the current is oscillating at many hundred thousand cycles per second and the heat effects are more deeply penetrating.

The home apparatus shown operates on a wave length of 15 meters and the approximate output is 200 watts. The improved circuit makes use of a single self-rectifying power tube, and the tubes carry a factory guarantee of 1000 hours of life. The oscillator may be tuned for different frequencies by means of a single dial and can be adjusted for mild or strong effects. The short wave diathermy apparatus is built on

a special chassis and encased in a brown Dupont fabrikoid case, handsomely finished.

(This article has been prepared from data supplied by courtesy of the Scientific Diathermy Corporation.)



Home S-W Diathermy apparatus in use for chest treatment.

## New Transmitter Kit

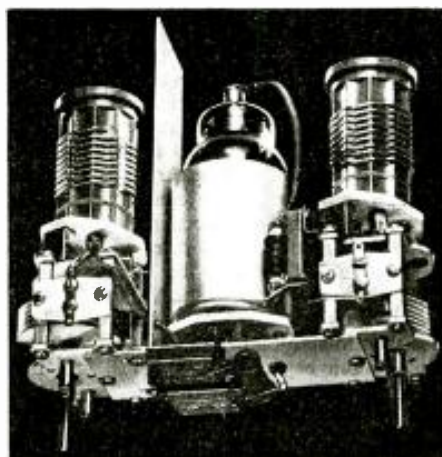

The new buffer-driver unit.

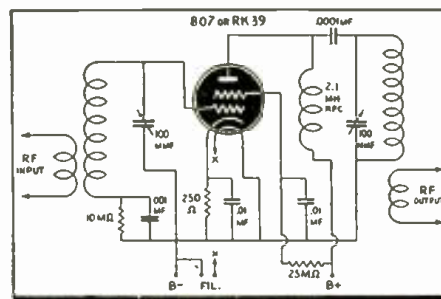

Basic circuit of the BD-40 kit.

● A NEW buffer-driver foundation kit for use with the PA-300 foundation kit has been announced by Hammarlund as the second in a series of amateur transmitter kits. The new unit, known as the BD-40, employs either an 807 or an RK-39 beam tetrode tube. It can be used either as a 40-watt output stage for a low-powered compact transmitter or as a driver for a higher-powered stage, such as the PA-300.

The kit includes everything necessary for assembly, including all hardware. As the photo shows, all the component parts are mounted either on a base plate which is fastened to the tuning condensers or on brackets also attached to the two condensers. The wiring diagram shows the fundamental circuit employed.

This article has been prepared from data supplied by courtesy of the Hammarlund Manufacturing Co.

## TINY ELECTROLYTICS

● A NEW metal-cased electrolytic condenser of extremely small size with an insulating jacket has been marketed by Aerovox. It is provided with 3½-inch pigtail leads and the protective jacket is spun over the end of the metal can so that these leads cannot possibly short to the can. The condenser is available in capacities



of 4 to 40 mf., and in working voltages of from 100 to 450.

This article has been prepared from data supplied by courtesy of Aerovox Corporation.



# BOOK REVIEW

**FREQUENCY CONTROL WITH QUARTZ CRYSTALS**, Engineering Bulletin E-6. Published by the Billey Electric Co., Erie, Pa.

This is a very valuable booklet of twenty-eight pages which every ham and serious radio experimenter should have for careful study. Many valuable diagrams are given and the complete story of the quartz crystal in its rôle of a frequency stabilizer is set forth so that anyone can readily understand it. The effects of temperature on crystals, various modes of vibration, different types of crystal holders, etc., are given.

We then come to a valuable section dealing with crystal-control oscillators, low frequency oscillators, frequency standards, primary and secondary standards of frequencies, the multi-vibrator, etc. No radio library is complete without this authoritative treatise on quartz crystals.

**PRACTICAL RADIO MATHEMATICS**, a Booklet for Home Study, by M. N. Beitman, B.S., 20 pages, illustrated, heavy paper covers. Published by Supreme Publications, Chicago, Ill.

This is a very useful treatise on the mathematics of radio for the home-study student. Numbers, fractions, decimals and the simplest basic formulas are first explained. The author then describes the meaning of such prefixes as milli and micro, radio examples of Ohm's law, how rectifier circuits are calculated, the calculation of wattage, etc. The calculation of resistance in series and parallel circuits, the calculation of inductive reactance, tables and formulas for calculating the different values of the decibel, etc., are also given fully.

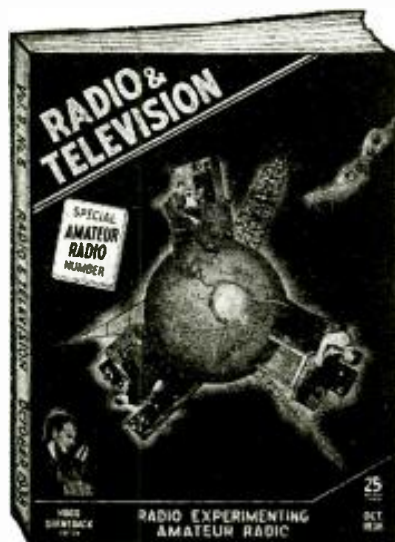

With the October number, *Short Wave & Television* will change its name to **RADIO & TELEVISION**. See inside front cover for details.

**PRINCIPLES OF RADIO**, Keith Henney. Size 5 3/4" x 8", 300 pages—illustrated, cloth bound, 49¢ pages. Published by John Wiley & Sons, N. Y.

This is the third edition of one of the best known hand-books on radio technical matters. It is a book which can be highly commended to those just entering the radio field and who wish to obtain a complete treatment of the subject. The opening chapters deal with the all-important fundamentals of electricity, the electron, the electric current, volts, amperes, watts, etc.

Then the author takes up the simple elements of curve plotting, Ohm's law, detection and measurement of voltage and current, how ammeters and voltmeters work and the measurement of resistance. Other important topics are—production of current by batteries, magnetic laws, alternating and direct current, coupled circuits, the meaning of self-inductance and the measurement thereof, the transformer and how it works, etc. The theory of condensers and series and parallel connections of these units are discussed, also the properties of alternating current circuits, what impedance means, as well as an explanation of capacitive and inductive reactance.

Resonance, high-frequency resistance, distributed capacity and the properties of coils and condensers in radio circuits are explained clearly. The vacuum

tube is allotted a liberal portion of the text and the elementary action of the grid and plate is clearly delineated. The use of the VT as an amplifier is explained with diagrams and clearly-written text. The various types of amplifier circuits, including the push-pull, Class B, and others are covered. Also the design of A.F. amplifiers, high frequency amplifiers, band-pass receivers, AVC, etc.

Rectifiers and power-supplies are described. Also oscillators and transmitters are described in detail. Antennas, transmission, especially short-wave transmission, anti-fading antenna systems, automobile aerials and a section especially devoted to facsimile and television transmission and reception are included.

**LIE DETECTOR TESTS**, William Moulton Marston. Stiff cloth covers, size 6" x 9", 180 pages. Published by Richard E. Smith Co., New York City.

Every student of science and criminology will find this book tremendously interesting and valuable. All of the various types of lie detectors are discussed and the ones finally found reliable are described. The reviewer found this book so interesting, especially in the chapter dealing with the Hauptmann case, that he could hardly lay it down.

A section is given which will prove interesting to police officials and the more technically inclined readers. A number of interesting graphs or charts of respiration and blood pressures are reproduced to show what happens when a subject attempts to lie. After reading this book it would seem that tomorrow everyone having to handle money or important documents in civilian and government bureaus will most likely have to pass a lie detector test, before they are finally appointed to the job. This, for the very good reason that actual tests showed that 33% of the employees in one bank had, at one time or another, taken money that did not belong to them.

This latest book on the science of lie detection (pardon us, "deception tests") as applied to banks and various other businesses, as well as for court cases of all kinds, makes most interesting reading.

**HANDBOOK OF CHEMISTRY AND PHYSICS—22nd Edition**, Editor-in-Chief—Charles D. Hodgman, M.S. Flexible leatherette covers; gold stampings; size 4 1/2" x 6 3/4"; 2,070 pages, gilt edges. Published by Chemical Rubber Co., Cleveland, Ohio.

The science and radio student will find this handbook of the greatest value, containing as it does a tremendous amount of information in cyclopedic form on mathematics, chemistry and physics, tables covering all of the usual trigonometric functions, as well as logarithms and anti-logs. The chemical tables are very elaborate and cover a considerable section. The elaborate table on physical constants of inorganic compounds, together with the table giving the constants of organic compounds, is worth the price of the book alone.

Other tables giving the properties of commercial plastics, the common names of chemicals and formulas, etc., are contained therein. The heat of formation and solution are covered in tabular form. The specific gravity for different concentrations of solutions such as acetic acid, aluminum chloride, aluminum sulphate, etc., are given. Tables for sulphuric acid, tannic acid and zinc sulphate are given, including ethyl alcohol.

Tables on the "properties of saturated steam" are included; also elaborate tables covering the specific resistivity of various metals. The basic laws and formulas for electricity and magnetism are presented for handy reference, as well as all types of tables and values for the various units of measurements, including the metric system.

The section on radio includes many basic formulas for calculating capacity and inductance, the various values of LC, data on radio tubes, including tables giving complete data on various television and commercial vacuum tubes—information not found in the average text-book.

Transmitting tube data is also tabulated, as well as different types of gaseous rectifiers, and diagrams are given of the various tube base connections.

Valuable recipes for various cements and other similar mixtures are given, including graining solutions, grinding mediums, glass silvering formulas, etc.

A tremendous compilation of scientific data covering every conceivable branch of pure and applied science, thoroughly indexed, is here presented in a single volume. All in all, it forms a book which should certainly find a place on every student's library table.

## RADIO INSTRUCTION

# You'll LEARN EASIER

## ... MAKE MONEY FASTER

with **SPRAYBERRY'S**  
PERSONAL HOME TRAINING  
IN **RADIO!**

**Actually Sets You Up for Business**

Be your own Boss! Get into the fast moving Radio industry. If you are an ambitious fellow, I can train you for a good paying full time or part time job... with a big future ahead. My training is distinctly new and different.

**Television Covered... Earn While You Learn**



Sprayberry Training not only covers thoroughly all phases and branches of Radio... it equips you for an actual start in business. I show you how to get profitable spare time Radio service work. Moreover, I show you how to do these jobs. You gain practical experience... add easy cash to your bank account while learning.

**BIG PROFESSIONAL OUTFIT GIVEN!**

Consists of All-Wave, All-Purpose Analyzer, Rider Manuals (7.976 pieces), Tool Kit, Electric Eye Outfit, Experimental Apparatus. THE SPRAYBERRY COURSE IS SOLD UNDER AN IRREVOCABLE MONEY-BACK AGREEMENT.

A. H. Lanier, Northbridge, Mass., writes: "Since enrolling I have cleared a net profit of more than \$150. in spare time alone. and I am not half through the Course yet. Honestly, I cannot understand how you give so much dope for so little money."

**SPECIAL SERVICEMAN'S COURSE**

Advanced Training for those already in Radio—teaches the easiest way to do the hardest jobs. Complete details of this advanced course and fundamental course, features, etc., fully described in my 48 page FREE book. Send for your copy today.



**Mail Coupon Now**

**SPRAYBERRY ACADEMY OF RADIO**  
F. L. Sprayberry, Pres.  
1454 J University Place, N.W.,  
Washington, D. C.

Please send me FREE copy of "More Money in Radio."

Name ..... Age .....

Address .....

City ..... State .....

Mail in envelope or paste coupon on postcard.

# LEARN CODE

the way you'll be using it  
by **SOUND**



There is only one way to learn to read code and that is by listening to code. There is only one way to learn to send code and that is by hearing your own sending repeated back to you. With the new All Electric Master Teleplex Code Teaching Machine you learn code the natural, easy, fascinating way. Only instrument ever produced which records your sending in visible dots and dashes—then SENDS BACK your own key work at any speed you desire. While not designated as standard equipment, Teleplex is used at many U. S. Army Posts, Naval Training Stations as well as the American Telephone & Telegraph Co. Also by practically every private school in the U. S. teaching code; and many foreign governments. We furnish complete course, lend you the All Electric Master Teleplex, give you personal instruction with a **MONEY BACK GUARANTEE**—all at a surprisingly low cost per month. Write today for FREE catalog 89. No obligation.

**TELEPLEX CO.** 72-76 Cortlandt St., New York, N. Y.

## RADIO ENGINEERING

# TRI-STATE COLLEGE

**DEGREE IN 2 YEARS.**

Complete Radio Engineering Course in 96 weeks. Bachelor of Science Degree. Radio (television, talking pictures and the vast electronic field) offers unusual opportunities for trained radio engineers. Courses also in Civil, Electrical, Mechanical, Chemical, Aeronautical Engineering, Business Administration and Accounting. Low tuition, low living costs. World famous for technical two-year courses. Those who lack high school may make up work. Students from all parts of the world. Enter September, January, March, June. Write for catalog. 2598 College Ave., Angola, Ind.

# RADIO INSTRUCTION

## EASIER THAN EVER

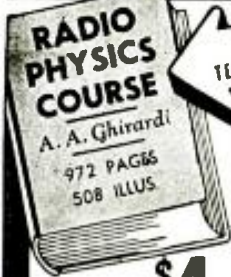

THIS 1 BOOK  
TEACHES YOU EVERYTHING

Without any previous training you can now master the whole science of Radio, Electricity and Television quickly and easily by reading Ghirardi's famous home-study RADIO PHYSICS COURSE. Its many exclusive features and plain easy-to-understand language account for its use by more radio schools and students than any other radio book in the world.

only \$4

HERE'S WHAT YOU GET:

Sound—Electrical Theory and Principles—Electrical Currents—Electromagnetism—Transformers—Inductance—Condensers—Measuring Instruments—Radioactivity—Broadcasting—Receiving—Vacuum Tubes—Amplification—Superhets—Coils—Speakers—Receivers of all types—Short-Wave—Auto-Radio—Aircraft Radio—Public Address—Photoelectric Cells—Cathode-Ray Tubes—Television—Testing and Servicing—Sound Motion Pictures—Reference Tables—556 Review Questions for Self-Study—and DOZENS of other subjects.

TRY IT!

Ghirardi's 1 Big Book will get you started in Radio quickly, simply, easily! Grab this marvelous bargain now—order your copy this easy way: write your name and address on this ad—send it in with \$4 today (\$4.50 foreign). Every penny of your money, back if not satisfied. Free circular—no obligation. Write at once!

RADIO & TECHNICAL PUBLISHING CO.  
45 Astor Place, New York, Dept. SWT-98

## TO LEARN RADIO!

### RADIO ENGINEERING



RCA Institutes offer an intensive course of high standard embracing all phases of Radio and Television. Practical training with modern equipment at New York and Chicago schools. Also specialized courses and Home Study Courses under "No obligation" plan. Catalog Dept. SW-38.

RCA INSTITUTES, Inc.

A Radio Corporation of America Service  
75 Varick St., New York, 1154 Merchandise Mart, Chicago

DO YOU LIKE

# RADIO & TELEVISION

If you want to know employment opportunities and requirements in radio and related industries, get National's book of facts.

Send for YOUR FREE COPY TODAY  
Dept. SW-C-9 4000 S. Figueroa



NATIONAL SCHOOLS  
Los Angeles

### RADIO COURSES

RADIO OPERATING: Prepare for Gov't License Exam. ● RADIO SERVICING: Including Short Wave ● AMATEUR CODE ● ELECTRONICS ● TELEVISION: Day and Evening Classes. Booklet Upon Request.

New York YMCA Schools  
6 W. 54th Street, New York City

### LEARN RADIO CODE

Now it is easy to learn the radio (continental) code. A newly designed, copyrighted, easy method—the fastest you have ever seen. Many report that they can copy at a speed of 5 to 10 words per minute after only a few minutes' study. Also used for blinker, heliograph, wig-wag, and submarine signaling. Mailed postpaid on receipt of only 50c. Address

TELECHART, Dept. 10  
Post Office Box 25, Knoxville, Tenn.

### BE A RADIO SERVICE EXPERT



Modern receivers require men with modern training for service work  
**LEARN AT HOME**

Our home instruction method and service equipment offer starts you earning money almost at once. Up to \$3 an hour easy in a short time. Write for free book  
Radio Training Ass'n of America  
Dept. SW-89  
4525 Ravenswood Ave., Chicago

## DX Receiving Aerials

(Continued from page 281)

Wavelength (Metres)	¼-wave Feeder Section	½-wave Aerial (in 2 ¼-wave halves)
25 m. B/C band	19 ft. 10 in.	39 ft. 7 in.
31 m. B/C band	24 ft. 6 in.	49 ft.
49 m. B/C band	38 ft. 2½ in.	76 ft. 5 in.

The spacing of the feeders in the quarter-wave matching stub is rather critical, and the line must be kept taut. Each side of the line must be of the same length, and must be symmetrical with respect to the ground. Any bends must be gradual if losses are to be reduced to a minimum. In addition the transposed transmission line must be kept at right angles to the aerial for a distance at least equal to one-third of the total length of the aerial.

A further variation of the half-wave doublet is effected by increasing the length of each section of the aerial to a half wavelength (i.e., the total length is equal to a full wavelength). As in the case of the Johnson Q the twisted lead-in is attached not to the centre of the aerial, but to a quarter-wave matching stub, in which the wires are spaced from 4 to 6 ins. apart. (See diagram 3.)

This aerial will also function very efficiently on a wavelength equal to twice its total length in metres. Thus if designed for 20 m. reception, it will give good results on 40 m.

The directional qualities of both these improved half-wave doublets are much the same as those of the simple half-wave doublet, being, if anything, more pronounced—there is less endwise pick-up.

### The "V" Antenna

Next to the single wire aerial, the easiest to construct for directional effects is the "V." Two examples of this are shown in diagrams 4 and 5. In diagram 4 the side wires are a full wavelength in length, and form an angle of 110 degrees; they are connected to a quarter-wave matching stub (as in diagrams 2 and 3). In diagram 5 the side wires are longer, each two wavelengths, and the angle is accordingly less, 75 degrees.

These "V" aerials are extremely directional—bi-directional.

### "V" Antenna Angles

(Setting out the angle between the two legs of a "V" aerial for various leg lengths.)

Leg-Length (in Wavelengths)	Angle
½ wavelength	160 degrees
1 wavelength	110 degrees
1½ wavelengths	90 degrees
2 wavelengths	75 degrees
3 wavelengths	65 degrees
4 wavelengths	50 degrees

### Diamond, or Rhombic Antenna

A considerable improvement on the "V" aerial is the diamond, or rhombic aerial shown in diagram 6. This is simply a "V" aerial backed up against another "V."

The diamond aerial should not be tilted in any plane. In other words, the poles should be the same height, and the plane of the aerial should be parallel with the ground. Tilting the aerial merely interferes with its directional qualities.

In constructing the diamond it is important to consider the angle A, which varies with the length of the sides (see following table).

Diamond Antenna Angles	Length of Sides (in Wavelengths)	Angles (see diagram 6)
1 wavelength	60 degrees	60 degrees
1½ wavelengths	80 degrees	80 degrees
2 wavelengths	95 degrees	95 degrees
3 wavelengths	115 degrees	115 degrees
4 wavelengths	125 degrees	125 degrees

If the terminating resistance, R (diagram 6), is included, the diamond aerial is not critical with respect to frequency, and gives an evenly good performance over a wide range. In this respect it is much superior to the aerials previously discussed. With the inclusion of R the aerial is uni-directional as indicated in diagram 6.

With the elimination of the resistor (R), we have a tuned diamond aerial which is quite suitable for U.H.F. work. It is bi-directional (diagram 6).

### The "V" Doublet

The "V" doublet (diagram 7) is probably the best aerial for all-wave reception. It differs from the elementary doublet, which tends to favor certain frequencies and reject others.

The "V" doublet is coupled to the transmission line by the converging "V." This makes the doublet respond uniformly to a wider range of shortwave signals; and the "V" matches the doublet more perfectly to the transmission line, so that the signal transfer is smooth. The reason for this is simple. At the top, where the spacing is wide, the characteristic impedance is high and comparable to that of the doublet, at the bottom, where the wires are close together, it is low to match the low impedance of the transmission line.

The "V" doublet illustrated in diagram 7 will give reasonable results between 16 and 50 metres, with the optimum response on 16 and 25 metres.

### The "Triple V" Doublet

The "Triple V" doublet shown in diagram 8 is essentially the same as the standard "V" doublet of diagram 7. Its chief advantage lies in the fact that it requires less space—having a span of only 40 feet, instead of the 50 feet required by the "V" doublet.

As in the case of the "V" doublet the dimensions given in the diagram are designed to give good performance over the short-wave broadcast bands.

### The Inverted "V"

The inverted "V" aerial (shown in diagram 9) consists of a wire supported in the form of an inverted "V" by a tall pole. One end of the wire is grounded through a non-inductive resistor of 400 ohms, whilst the other end is fed to a transmission line, which is transposed at convenient intervals.

(Continued on page 320)

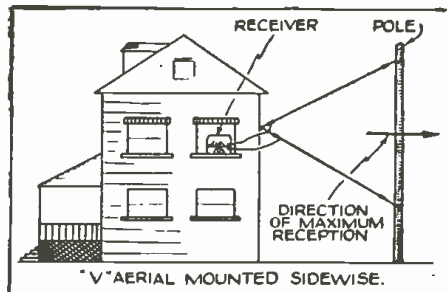

An idea! Erect the "V" aerial sideways—the maximum reception lies in the direction of the open "V."



# Portable 30-Watt Xmitter

(Continued from page 297)

would be advisable to provide a well insulated switch to short out the modulation choke so that surges through same would not cause arcing at the base of the 5Z3 rectifier tube.

If these details are followed out in accordance with the above data there shouldn't be any of the usual bugs found in most circuits, as they have actually been ironed out in practise and not just on paper. The reports on quality have been most gratifying and with a number of measuring devices employed from time to time, it was proven that 100% modulation was obtainable without a trace of audible distortion. Numerous foreign countries have been worked on 10 and 20 meter phone, with R reports exceeding all expectations.

## Operating Instructions

For 160 meter operation insert crystal, oscillator coil, and final tank coil. Place SW. No. 5 in the straight through or up position. There is no trick in tuning up the transmitter for anyone familiar with such apparatus, as there are only three readings necessary. It is not advisable to load the final past 80 ma. About 5 ma. excitation is plenty and in fact the crystal will have to be slightly de-tuned to keep from overdriving the final amplifier. Oscillator current should be about 35 ma.

For 80 meter operation the above can be followed through in the same manner, if it is desired to do so. However, an 80 meter crystal is necessary.

If it is preferred to double to 80 meters with a 160 meter crystal it will be necessary to place SW. No. 5 in the double or down position. Then, of course, the second triode of the 6A6 is brought into play as a doubler and tuned up in the conventional manner.

For 40 meters the instructions would be the same as that of 80 meters.

For 20 meter operation a 40 meter crystal can be used or an 80 meter crystal with the second triode of the 6A6 picking up the 4th harmonic.

On 10 meters a 40 meter crystal is used with the second section of the 6A6 picking up the 4th harmonic. SW. No. 2 is in the on position, thereby raising the voltage slightly to the 6A6. C11 will have to be adjusted until ample output is obtained to properly excite the final amplifier. This condenser is the most critical adjustment in the complete circuit. It controls the regeneration of the multiplier section of the 6A6. It was found best to adjust this so

that maximum output was obtained without the circuit "taking off," and then very slightly reducing the capacity. With the crystal removed there should be no trace of R.F. whatsoever. It is further advisable to make this adjustment with the plate and screen voltage off the final amplifier. After this procedure is completed once, it need not be necessary to ever adjust C11 again. In fact, it is advisable to place the transmitter in operation on the 10 meter band first. The antenna coil and condenser (L5 and C13) need not be used on any band, provided the antenna is of the doublet or some other untuned type. Where a Marconi or Zepp type antenna is desired, the final tank coil can be linked to the antenna coil with two turns on each coil.

The plate current on the 6A6 should not exceed 40 ma. and the voltage should be kept under 300 (measured between cathode and plate).

It was found that cheaper makes of 6A6 tubes would not function at all in the oscillator-multiplier section of transmitter. There has been no instability in the oscillator, even though regeneration is employed.

The final amplifier operates quite well loaded to 80 ma. on each of the above mentioned bands. No neutralization is necessary on this type of tube on any band. Minimum current on 10 meters is 14 ma. and graduates down to 8 ma. on 160 meters.

The reason for connecting the two 1,000 ohm resistors (R7) in parallel was that the inductive type didn't function properly on 10 meters. In order to obtain a resistor with a four or five watt rating, these two non-inductive types were connected in this manner.

Not being able to obtain a padding condenser with the correct voltage rating the two small trimmers were placed in parallel. When one alone was used it would arc over occasionally, as the plates were too close together when it was adjusted to the required amount of capacity.

## Parts List

### AEROVOX (Condensers)

C1—001 mf. 1000 v. oil  
C3—1 mf. 100 v. paper  
C4—4 mf. 600 v. oil  
C6—25 mf. 75 v. electrolytic  
C7—4.4 mf. 450 v. electrolytic  
C8—002 mf. mica

### HAMMARLUND

C9—100 mmf. variable condenser, type APC-100  
C10—35 mmf. variable condenser, type MC35-S  
C11—30 mmf. trimmer condenser (2 in parallel)  
SWF coil forms, as required  
CF5 coil forms, as required

(Continued on page 307)

## Coil Data

		160	80	40	20	10
Oscillator L1	Number of turns	48	30	15		
	Wire size	26	22	18		
	Spacing btw. turns	None	None	None		
	Space btw. L1 & L2	¼ In.	5/16 In.	5/16 In.		
Frequency multiplier Grid L2	Number of turns	62	34	18		
	Wire size	28	26	24		
	Spacing btw. turns	None	None	None		
	Space btw. L2 & L3					
Frequency multiplier plate L3	Number of turns	42	23	13	7	
	Tap from top of coil	18	13	7	4	
	Wire size	20	20	18	18	
	Spacing btw. turns	None	None	None	Diam. of wire	
Final Grid L4	Number of turns	31	17	14	7	
	Wire size	26	24	20	18	
	Spacing btw. turns	None	None	Diam. of wire		
	Space btw. L3 & L4	¼ In.	¼ In.	¼ In.	¼ In.	
Final Plate L5	Number of turns	45	30	21	11	6 (1½ In.)
	Wire size	20	20	18	18	14 (outside diam.)
	Spacing btw. turns	None	Wire diam.			
Antenna L6		35 Turns No. 20 wire on a 2 inch form. Tap every 12 turns.				

10 meter final tank coil (L5) is air-wound and self-supporting. Three old tube prongs were soldered on the coil ends and center-tap and spaced the same as prongs 3, 4 and 5 would be on a regular 5 prong coil form. 20 meter final tank coil (L5) is wound on a Hammarlund form No. CF-5. 10 meter multiplier coils (L3 & L4) are also on form No. CF-5. All other coils are on the regular 5 prong coil form No. SWF-5. The SWF-5 coil form has provisions for inside mounting of C9 Hammarlund part No. APC-100.

GOOD RESULTS DEMAND  
Good Instruments!



SELECT A

TRIPLET

18 STYLES  
2" to 7"

4" Modernistic Square  
Instrument . . . A.C. or D.C.  
All Popular Ranges

Round, Square  
Fan or Twin Cases

MOST MODELS AVAILABLE WITH FRONT OR  
REAR ILLUMINATION

Today's Most Modern Instruments . . . New methods and extremely accurate processes are embodied in Triplet instrument designs. The first considerations are for dependable accuracy, simplicity, and the best application of the fewest number of parts. An example is the long research in developing a super-magnet (the heart of the instrument) by means of which it has been possible to eliminate extra pole pieces. This achievement has brought from prominent laboratories, graphs that prove Triplet magnets give more uniform scale characteristics. Magnet air gaps are absolutely uniform because they are made without tolerance in size after the magnet is hardened by thoroughly proven exclusive Triplet processes. The same painstaking methods apply to aging of all materials after processing to relieve strains and assure proper adjustments; care in selecting pivots and jewels and applying them in exact alignment. Infinite care in every form is exercised throughout in Triplet's modern, fully air-conditioned plant under the supervision of engineers of long standing instrument building experience. This unique instrument set-up is available to you as a most reliable complete organization where full confidence may be had in valuing such products to your needs.

Ask Your Jobber or Write  
for Complete Catalog

Triplet Electrical Instrument Co.

289 HARMON DRIVE - BLUFFTON, OHIO

## THORNE'S RADIO COIL WINDER

DESIGNED  
FOR THE  
AMA-  
TEUR  
AND  
RADIO  
REPAIR  
SHOP

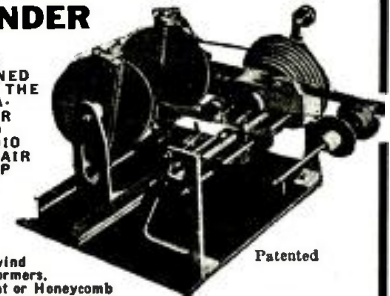

Will wind  
Transformers,  
Straight or Honeycomb  
coils and Ear Phone  
armatures. Revolution recorder. 14 Speed changes.

Write for Illustrated Circular and Price.  
MIAMI LABORATORIES, INC.  
951 N. W. Third Street Miami, Florida

Listen Comfortably with  
**BRUSH "Hushatone"**  
(pillow speaker)

Put this radio accessory under your  
pillow and listen to your favorite  
programs. Write for details.

The BRUSH DEVELOPMENT Co.

3326 Perkins Ave., CLEVELAND, OHIO

# STOP, LOOK & BUY!

## Rockbottom Prices On Surplus, and Army and Navy Merchandise

When prices are low we buy! They're low now—LOWER THAN THEY EVER WILL BE—hence this sale. Most of the merchandise is new—never used; some of it reconditioned. 100% satisfaction on each transaction or your money refunded.

ORDER FROM THIS PAGE. Use the convenient coupon below. Be sure to include sufficient extra remittance for parcel post charges, else the order will be shipped express, charges collect. Any excess will be refunded. C.O.D. shipments require a 20% deposit. If full remittance accompanies order deduct 2% discount. Send money order—certified check—new U. S. stamps. No C.O.D. to foreign countries.

ORDER TODAY QUANTITIES LIMITED QUICK SHIPMENTS ASSURED

### EDISON 1/50TH H.P. UNIVERSAL MOTOR

Made by Edison Electric Co. for Dictaphone machines. Can be used on 110 volt D.C. or A.C. lines (any frequency on A.C.). Double shaft. 5/16th in. diam. Any speed obtainable with suitable rheostat. Size 9" x 4" high, x 5 1/2" wide overall. Shp. Wt. 8 1/2 lbs.



ITEM NO. 10  
Your Price ..... \$2.25

### VARIABLE SPEED UNIVERSAL MOTOR

FOR 110 VOLTS, A.C. OR D.C. Made for Dictaphone machines by American Gramophone Co. Used in excellent condition. Special lever control permits variable speeds up to 3000 r.p.m. Variable shaft extends from both sides of motor. Measures 7 1/2" x 3 1/2" diam. overall. Shp. Wt. 6 3/4 lbs.



ITEM NO. 11  
Your Price ..... \$2.55

### SPERRY GYROSCOPE LIQUID COMPASS

Made for U.S. Signal Corps; sensitive and accurate. Quick readings easily made from top; accurate readings of graduations through focusing magnifying lens on side of instrument. Complete with level sights and russet leather carrying case. Excellent for boats, boy scouts, campers, hikers, etc. A few turns of wire around its case makes it usable as a Galvanometer. Shp. Wt. 3 lbs.



ITEM NO. 12  
Your Price ..... \$1.85

### PORTABLE TELEGRAPH AND BUZZER FIELD SETS

Made for military use by Western Electric. A wonderful buy if only for the parts it contains. Never been used. Good for code practicing, signaling, communications, etc. Contains 2-tone, high-frequency buzzer with platinum contacts, telegraph key, telephone switches, earphone, condenser, transformers, chokes, etc. A \$50 value easily. Complete in wooden case with diagrams and instructions. Shp. Wt. 12 lbs.



ITEM NO. 16  
Your Price ..... \$5.45

### PRISMATIC RIFLE SIGHT AND OBSERVERS' SCOPE

Made by Warner & Swasey. Consists of automatic ocular and objective lens (6 power), calibrated reticule with cross hairs, 2 highly polished prisms set in solid bronze frame with soft rubber eye cup. Micrometer adjustments for yardage and windage. Range 50 to 5000 yds. Used on Krak, Enfield, Savage, Springfield, etc. With mount and leather case. Shp. Wt. 4 lbs. Regular price \$38.00.



ITEM NO. 18  
Your Price ..... \$8.95

### TELEGRAPHIC TAPE RECORDER

A wonderful buy! Apparatus makes a written record of code and similar messages on paper tape. An ideal machine for learning code or teaching code to groups. Radio men can easily adapt it to short-wave receivers for taking permanent records of code messages. Double pen permits simultaneous recording of two messages. Pens are operated by battery and key while tape feeder is spring driven (hand wound). Case made of solid brass on heavy iron base. Completely reconditioned. (Less tape; easily obtained anywhere.) Original cost \$85.00. Shp. Wt. 20 lbs.



ITEM NO. 20  
Your Price ..... \$19.95

### ARMY AIRCRAFT KEY

Type J-E Army aircraft solid brass transmitting key with large heavy duty tungsten contacts. Well balanced action—easy on the fist. Shp. Wt. 2 lbs.



ITEM NO. 22  
Your Price ..... \$1.90

### WESTERN ELECTRIC BREAST MIKE

A lightweight aircraft-type carbon microphone, with breast plate mounting. Can be adapted for home broadcasting or private communication systems. With cord and plug. Shp. Wt. 4 lbs. (Illustrated at right.)



ITEM NO. 14  
Your Price ..... \$2.45

Magnavox Anti-Noise Microphone, also good for home broadcasting, etc. With cord and plug. Shp. Wt. 2 lbs.

ITEM NO. 15  
Your Price ..... \$1.80

### NAVY PORTABLE SEARCHLIGHT

Cast aluminum and fire housing. Mangin type parabolic glass reflector 5" diam. Trigger switch and handle for operating, tilting and focussing lamp. Made by General Electric and National X-Ray Co. for U.S. Navy. Measures 4" deep x 5 1/2" diam. overall. Focal length 15 1/2". Approximately 100 candle power. Has threaded nipple for 3/8" pipe support. Complete with wooden carrying case. Excellent for camp trailers, barns and outdoor and indoor displays. Supplied with either 6 or 12 volt lamp. Shp. Wt. 14 lbs. (Net 4 lbs.)



ITEM NO. 17  
Your Price ..... \$6.65

### AIRCRAFT GENERATOR PROPELLER

"DeSauriers" automatic centrifugal pitch. Operating speed 4500 r.p.m. Blade 11 1/2" x 2 1/2" sweep, 23° aluminum and bronze housing. Complete with streamlined housing (shown dotted). Fits 9/16" shaft. Net weight 5 1/2 lbs. Shp. Wt. 7 1/2 lbs. Original cost \$200.

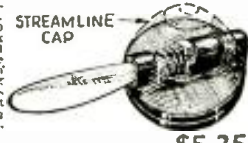

ITEM NO. 19  
Your Price ..... \$5.25

### STREAMLINE CAP



ITEM NO. 21  
Your Price ..... \$29.70

### NAVY FLOODLIGHT

Made to U.S. Navy rigid specification these sturdily constructed floodlights are now available at less than half of their original price of \$70.00. Brand new merchandise never before used. Pittsburgh floodlight type FLC-500, 16" Durex aluminum reflector. Floodlight has double adjustments and is weatherproof. Takes 300 watt 50 watt mogul base lamp. Measures 18" x 18" x 2 1/2" overall. Shp. Wt. 55 lbs.



ITEM NO. 21  
Your Price ..... \$29.70

### ANTI-CAPACITY SWITCHES

Made by Western Electric. Double throw switch with 12 terminals—equivalent to two double-pole, double-throw switches. All contacts are of platinum plate. Original price \$3.50 each. Shp. Wt. 1 lb.



ITEM NO. 23  
Your Price ..... \$1.55

## Suppressor-Grid Control

(Continued from page 291)

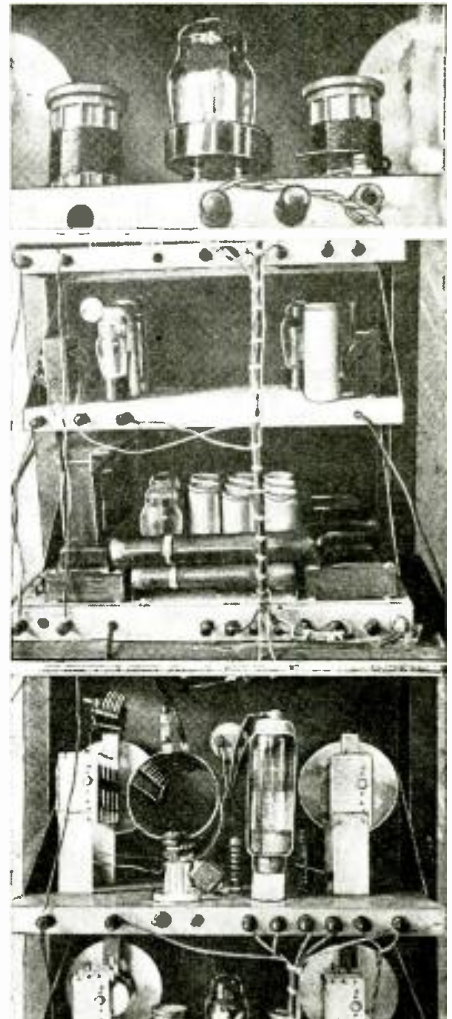

Three photos above show respectively—rear view of crystal oscillator; modulator and power-pack; complete view of final amplifier.

### Parts List for Transmitter

- 1—Low-loss 7-prong socket
- 3—Low-loss 5-prong sockets
- 1—SPST toggle switch
- 2—closed circuit jacks
- 4—four-prong sockets for coils
- 1—phone plug
- 1—0-100 ma. Triplett meter
- 1—0-300 ma. Triplett meter
- 1—crystal of selected frequency
- 1—SPST switch, rotary type
- 1—6-terminal strip
- 3—r.f. chokes, transmitting type
- 1—2 megohm, 1 watt resistor
- 1—75 ohm center-tapped resistor
- 1—0.5 amp. r.f. ammeter
- 1—.006 mf. mica condenser
- 1—.005 mf. mica condenser
- 1—.05 mf. 600 v. condenser
- 4—.002 mf. mica condensers
- 1—.005 mf. 2000 v. condenser
- 2—.0001 mf. 1000 v. mica condensers

This article has been prepared from data supplied by courtesy of Allied Radio Corp.

## Can YOU Answer These Radio Questions?

(Continued from page 268)

the new 6F8G dual triode tube, especially for T.R.F. receivers? See page 292.

11. How would you connect a beat oscillator; what is its purpose? See page 294.

12. How can regeneration be made use of in a crystal controlled oscillator for a transmitter? See page 296.

WE HAVE NO CATALOG. ORDER FROM THIS PAGE.  
HUDSON SPECIALTIES - 40-T West B'way - N.Y.C.  
IT'S EASY TO ORDER—CLIP COUPON—MAIL NOW

HUDSON SPECIALTIES CO., 40-T, West Broadway, N. Y. C.  
I have enclosed below the numbers of the items I'm ordering. My full remittance of \$..... (Include shipping charges) is enclosed.  
OR my deposit of \$..... is enclosed. (20% required), ship order C.O.D. for balance. (Now U.S. stamps check or money order accepted.)

Circle Item No. wanted: 10 11 12 14 15 16 17 18 19 20 21 22 23

Name ..... Address .....

City ..... State .....

Send remittance by check, stamps or money order; register letter if you send cash or stamps.



# Build This "5 in 4" All-Wave T. R. F. Receiver

(Continued from page 293)

but these leads should not be excessively long. The various paper and mica condensers and fixed resistors are mounted directly on the parts themselves, being held in place by their own tinned leads.

Although the diagram does not show this, most of the *negative* connections, wherever this is practical, are brought out to a *single spot* on the chassis. This type of construction eliminates the losses and noise due to eddy currents which would result if the connections were made to several different points.

Be sure that the paper condensers are of good quality, especially the 0.1 mf. blocking condenser between the 6F6G plate and the crystal headphones; a small amount of direct current leakage through this condenser will damage the crystal phone elements beyond repair. Unless otherwise specified all paper dielectric condensers used in this receiver are of 600 d.c. *working* volts rating.

When the wiring has been completed, place the coils and tubes in their respective sockets and turn the regeneration control full-on. The detector circuit is now checked for oscillation by placing a finger on the fixed plates of the detector tuning condenser; if everything is correct, a loud click will be heard in the headphones immediately upon making the contact and another when the finger is removed. If no click is heard, this indicates a lack of oscillation and it may be necessary to *reverse* the tickler connections to the 6F8G cathode, or increase the detector plate voltage by reducing the value of the fixed resistor in series with the regeneration control and the "B"-plus of the power supply. If the detector seems to be operating, connect the doublet antenna leads to the receiver as shown in fig. 1 and turn up the audio volume control about three-fourths way full-on. Adjust the regeneration control until a slight hissing sound is heard in the phones, rotate the dial for a signal and set the r.f. trimmer condenser for best reception. The maximum sensitivity is obtained when the 50,000 ohm potentiometer is adjusted *just below* the point where oscillations begin.

Either a doublet or a plain single wire may be used for the antenna. If a single wire is used, the most efficient length for all-wave operation will be around 75 feet.

## List of Parts

### HAMMARLUND (Condensers)

- 1—Split-stator tuning condenser, 140 mmf. per section, MCD-140-M
- 1—Midget tuning condenser, 35 mmf., MC-35-S
- 1—Set 4-prong "XP-53" plug-in coils, SWK-4
- 1—Set 6-prong "XP-53" plug-in coils, SWK-6
- 1—Midget r.f. choke, 2.1 mh., CH-X
- 1—Detachable coil shield, CS-3
- 1—4-prong isolantite socket, S-4
- 1—6-prong isolantite socket, S-6
- 2—8-prong isolantite sockets, S-8
- 2—Aluminum tube shields, TS-50

### I.R.C. (Resistors)

- 1—Fixed resistor, 1/2 watt, 300 ohms
- 1—Fixed resistor, 1 watt, 2,000 ohms
- 2—Fixed resistors, 1 watt, 100,000 ohms
- 2—Fixed resistors, 1 watt, 50,000 ohms
- 1—Fixed resistor, 1/2 watt, 1 megohm
- 1—Fixed resistor, 1/2 watt, 3 megohms
- 1—Fixed resistor, 1 watt, 1/2 megohm
- 1—Volume control, 50,000 ohms (with A.C. switch)
- 1—Volume control, 500,000 ohms
- 1—Wire-wound resistor, 10 watts, 500 ohms
- 1—Wire-wound resistor, 50 watts, 15,000 ohms

### AEROVOX (Fixed Condensers)

- 2—0.1-0.1 mf. paper condensers, dual type, 600 volts
- 1—0.1 mf. paper condenser, 600 volts (see text)
- 2—0.01 mf. paper condensers, 600 volts
- 1—1 mf. paper condenser, shielded type, 400 volts
- 2—0.05-0.05 mf. paper condensers, dual type, 600 volts
- 1—Dual electrolytic condenser, 10-10 mf., 50 w.v.
- 1—Triple electrolytic condenser, 8-8-8 mf., 450 w.v.
- 1—Mica condenser, with wire leads, 0.0001 mf.
- 1—Mica condenser, with lugs, 0.006 mf.
- 1—Mica condenser, with lugs, 0.001 mf.

### R.C.A. (Radiotron Tubes)

- 1—6S7G tube
- 1—6F8G tube
- 1—6F6G tube
- 1—5U4G tube

### JEFFERSON ELECTRIC CO. (Transformers)

- 1—Power transformer with 600 volt c.t., 5 volt and 6.3 volt windings. Type 463-411
- 2—Filter chokes, 30 henries, 50 ma., type 466-590

### MEISSNER MFG. CO.

- 2—Bakelite sockets, spring-mounting type

### BUD RADIO, INC.

- 1—Steel, crackle finished cabinet, 7 x 14 x 18 inches. No. 995, with chassis and panel to match. See text

### CROWE

- 1—"Front-o-panel" dual ratio dial. Type 525
- 3—Notched pointer knobs

### BRUSH DEVELOPMENT CO.

- 1—Pair crystal headphones. Type "A"

### MISCELLANEOUS

- Tip-jacks, hook-up wire, solder, etc.

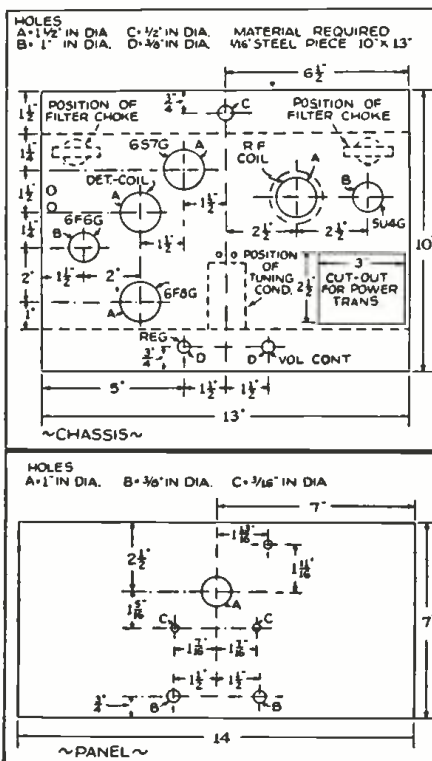

Dimensions of chassis and panel.

## Your Inquiries Invited

When you need amateur equipment it is to your advantage to write to Bob Henry, W9ARA. You get personal attention; terms financed by myself so you buy with less cost and more convenience; fair trade-in value for your equipment; ten day trial of all receivers; and my cooperation in every way to see that you are 100% satisfied. No wonder Bob Henry's customers are boosters. You will be too. For the newest equipment, the latest information and technical help:

WRITE TO:

**BOB HENRY,**  
BUTLER, MISSOURI

### Compare Bob Henry's Terms with Others

Model and Receiver	Cash Price	Down Payment	12 Mo. Payments
The NEW NC-44	\$49.50	\$9.95	\$3.52
NC80X and NC81X	99.00	19.80	6.99
Improved NC101X	129.00	25.80	9.11
The NEW NC100A	120.00	24.00	8.48
The NEW RME-69	141.03	28.20	9.98
Sky Champion	49.50	9.90	3.49
Sky Challenger II	77.00	15.40	5.44
Super Skyrider	99.00	19.80	6.99

Also Super Pro, HRO, PR15, Breting 9, Sargents, others.  
Similar terms on Harvey, RCA, RME, Bassett, Temco transmitters and National, Progressive, Utah, Stancor kits.

Special Department for Export Orders

## HENRY RADIO SHOP

211 North Main Street Butler, Missouri

## MULTI-UNIT MICROPHONE



**ASTATIC**

Brand new! Public address and night club leader. Cannot be acoustically overloaded. Made in two models.

**ASTATIC MICROPHONE LABORATORY, INC.**

Dept. J-2, Youngstown, Ohio  
Licensed Under Brush Development Co. Patents

Write for Literature

## PHONOGRAPH RECORDS

- 12 Decca, Bluebird or Vocalion Records, \$1.
- 8 Victor, Columbia or Brunswick Records, \$1.

Each record is the standard 10" and plays both sides.

Hot dance numbers, vocal instrumental, waltzes, old timers, cowboy, hill billy, etc.

All popular artists. Hurry while they last. No. C.O.D.

Send For Our Giant Summer Catalogue

**UNITED RADIO CO.**

58-P MARKET ST. NEWARK, N. J.

**5 METER CRYSTAL CONTROL**

*Bliley* HF 2-10 METER CRYSTAL

Your Bliley dealer will tell you how to build a simple, highly efficient 5 meter crystal controlled transmitter. Bliley Electric Co., Erie, Pa.

# Television Terms Explained

(concluded)

**POSITIVE POLARITY OF TRANSMISSION**—The opposite of "Negative Polarity Of Picture Transmission." In this case, where the light on the image being scanned and reproduced *increases*, the power in the antenna also *increases*, and where the light *reduces*, on the image, the power in the antenna also reduces.

—R—

**RADIO FREQUENCY TELEVISION SIGNAL**—The completely modulated R.F. carrier wave of a television transmitter when such modulation includes all video, synchronizing, and blanking signals.

**RAIN**—A term descriptive of the appearance of rain when a signal is being televised which has a poor signal-to-noise ratio. The splashes producing the effect of rain are caused by static, thermal agitation, and other disturbing factors that have an amplitude comparable to the all-too-weak television signal.

—S—

**SCANNING**—The process of an orderly dissection of a televised picture into minute elemental areas of varying light intensities, each element occurring at both the transmitter and receiver in a logical order, which, when reconstructed, will give the complete picture.

**SCANNING FIELD**—The area of the picture frame traversed by the scanning spot either in the operation of image dissection or scanning in the picture tube or in the reproduced television image.

**SCANNING GENERATOR**—The circuit employing a vacuum tube which is used to generate the linear saw-tooth wave neces-

sary for both the vertical and horizontal scanning motions of the scanning spot on the cathode ray screen.

**SCANNING INTERFERENCE**—A disturbance in the television picture caused by cross-talk between scanning and audio frequency channels.

**SINGLE SIDE-BAND TRANSMISSION**—Transmission of voice or other intelligence with only one side band and the carrier in contrast to the more common system using Double Side-Band Transmission.

**SYNCHRONIZATION**—A means whereby the scanning spot at the receiver is made to keep in step with the scanning spot of the transmitter.

—T—

**TELECINE TRANSMISSION**—The process whereby a film is used for the subject to be televised.

—V—

**VERTICAL BLANKING IMPULSE**—The same as "Field Frequency Blanking Impulse."

**VERTICAL SYNCHRONIZING IMPULSE**—The same as "Field Frequency Synchronizing Impulse."

\* \* \*

### Supplemental Television Information

The Federal Communications Commission has specifically defined the various classes of Visual Broadcast Stations, namely, Television and Facsimile, as follows:

1030—The term "visual broadcast station" means a station carrying on the broadcasting of images for general public reception. There are two classes of visual broadcast

stations, namely: television broadcast stations and facsimile broadcast stations.

1031—The term "television broadcast station" means a station licensed for the transmission of transient visual images of moving or fixed objects for simultaneous reception and reproduction by the general public.

1032—The term "facsimile broadcast station" means a station licensed to transmit images of still objects for record reception by the general public.

Quoting from the same general bulletin of the FCC: "(b) A license for a television broadcast station will authorize the use of two adjacent frequencies in any one group. The lower carrier frequency shall be for visual broadcast and the higher carrier frequency for the aural broadcast."

\* \* \*

It should be mentioned that while both a sight and sound station are thus incorporated under one license, these are actually *two separate transmitters*. By this means the FCC has provided the combination of both sight and sound to the same program, thus adding to the enjoyment of the public. Both stations are licensed under the one group of call-letters assigned. Thus, W9XAL is the call-letter designation of both First National Television's ultra-high frequency television and sound stations.

\* \* \*

**OSCILLOGRAM**—A permanent record of the pattern appearing on the screen of an oscillograph in the observation of transient phenomena.

Copyrighted by First National Television, Inc.—1937. Prepared by Everett L. Dillard, Tech. Supervisor Resident Training, First National Television, Inc., Kansas City, Missouri.



↑  
THIS  
SHADE  
TILTS  
UP AND  
DOWN

This **MODERN DESK LAMP**  
Is Yours Absolutely **FREE**  
With a Year's Subscription to **SHORT WAVE & TELEVISION**

**JUST THINK OF IT**—you can get absolutely **FREE**, the beautiful desk lamp shown at the left. This attractive desk lamp is suitable for home, desk, den, office, laboratory, studio or workshop. It is sent to you by the publishers with their compliments for a one-year subscription to **SHORT WAVE & TELEVISION**. Look at the many fine features which this handsome desk lamp has. Read the list below.

### LOOK AT THESE FEATURES!

- ⊛ Constructed of metal with attractive bronze finish.
- ⊛ Scientifically constructed to give glareless, diffused light.
- ⊛ Helmet-type shade can be tilted to any convenient angle.
- ⊛ Stands 13" high and has 10" metal shade.
- ⊛ 5-foot rubber insulated cord and plug.
- ⊛ Constructed to last for many years.

### Clip Coupon Today — and Mail!

Send your subscription today to **SHORT WAVE & TELEVISION** for One Year (12 issues) and receive absolutely **FREE** one of these truly remarkable desk lamps. New subscribers are accepted or you may extend your present subscription another twelve months under this offer. Mail your remittance of \$2.50 (Plus 25c for shipping charges on lamp) to the publishers of **SHORT WAVE & TELEVISION**. (Canada and foreign \$3.25) You will promptly receive your **FREE DESK LAMP** by return mail. Use the coupon at the left to order your subscription.

### SHORT WAVE & TELEVISION

99 Hudson Street



New York, N. Y.

#### SHORT WAVE & TELEVISION, 99 HUDSON ST., NEW YORK, N. Y.

Gentlemen: Enclosed you will find my remittance of \$2.50 for which enter my subscription to **SHORT WAVE & TELEVISION** for one year (12 issues). Send me promptly my **FREE DESK LAMP**. (Canada and foreign \$3.25.) In U. S. add 25c additional to cover shipping charges of lamp.

( ) NEW SUBSCRIBER ( ) EXTEND PRESENT SUBSCRIPTION

Name .....

Address .....

City ..... State .....

(Send remittance by check, money order or unused U. S. Postage stamps. Register letter if you send cash or stamps.)

SW-034



# Let's Listen In with Joe Miller

(Continued from page 277)

**PHILIPPINES . . .** KAZ, 9.99 mc., Manila, logged using inv. speech at 5:35 a.m., with an R8 signal

## OTHER NEWS

**FINLAND . . .** The QRA of the Lahti broadcaster on 9.50 mc. will have to be altered, as we have received word from England that the correct QRA is: Oy. Suomen Yleisradio AB., Lahden Yleisradiosema, Lahti, Finland. No call letters known. Sked is, wkdays, 1-1:45, 5-6 a.m., and 10 a.m.-5 p.m. This station may also

of the cold seasons ahead that we will again give much time or thought to DXing, and guess you all feel the same about it, eh wot? Yet we must keep at it a bit in order to have some material for this ol' "colyum."

Reports plainly show that the other DXers feel as we do, judging from the paucity of dx logs submitted. If this continues—but we know it won't—we'll actually have to fall back on our own dx for a "colyum," blime, hi!!

Here's what we have:

## ASIA

J7CB, 14085, Japan, was logged at 3:30 a.m., calling "Ye Ed," as arranged by friend Shigeo, J3F1, but, as usual of late, data rec'd too late for publication. We have already logged J7CB before, too bad Shigeo didn't know that. Tnx anyway, OB!

J7CR, 14280, also was heard, at 3:20 a.m., fair signal, ann'd as "Canada-Russia." Max Fisher, W6, also reports J7CR, but on 14156. J2KN, 14500, also by Max.

PK3LC, our FB friend Clement, was logged lately, at 6:10 a.m., though condx were poor. That's some dx you've worked there on 15 watts, OM. Congrats!

PK1JR, 14330; PK1MX, 14330; PK1ZZ, 14300; PK2WL, 14120; PK1RI, 14350; PK4JD, 14090; PK4DG, 14348, all reported by our English DXer, Ian Jamieson, of Manchester. All above PKs in Java.

Ian also reports VS1AI, 14090, Singapore; VS7GJ, 14120, Ceylon; VU2DR, 14120, India; KA1BH, 14140, Philippines, all FB dx, OM!

PK6XX, with the New Guinea Expedition, is being widely reported, on 14020, and also, operating commercial, on 11.355 mc. News as to where to write for veris will be given in next issue. Tnx to Ashley Walcott for above.

Max Fisher reports KA7EF, 14122, on the island of Negros, Philippines, at 1 a.m.

## AFRICA

We cert got ourselves one grand thrill a coupla Sats. ago, when friend Murray was twiddling the dials of the SX17 on test here, and at 4:30 p.m. the surprise of our still young lives occurred when, on an R7 carrier, we heard an OM giving his call as FB8AH, Tananarive, Madagascar!!

That was indeed a shock, but what a pleasant one, hi! We still do get a kick outa hearing real good dx, but the way FB8AH came in, whew!! Must be our rhombic, or somcp'n. FB8AH ann'd as "FB8 America Honolulu, in Tananarive, Madagascar," and freq. was 14380.

Another very pleasant surprise was the logging of our friend, F. Paul Bour, FB8AB, also of Tananarive, one morning, at the unusual time for Africa, here on East Coast, 7:35 a.m., freq. was 14348. We had already logged FB8AB on 10 meters one noon, last fall, when he was actually on 20 meters, so Paul decided to give us the opportunity of logging his 20 meter signal, but this time, on 20 meters, hi! So he rushed us an air-mail from Madagascar, telling us he was going to give us a call for four successive days, twice per day, 11 p.m. and 7:30 a.m., but, as South Africans long ago died out near 11 p.m., and it was only a rare occurrence when South Africans were heard around 7:30, we had little hopes of hearing Paul calling us. But we did manage to get him through, though C.W. was bad at times. Many tnx to you, Paul, OM, you've certainly shown us the

(Continued on page 306)

## Setting New Standards for Midget Condenser Performance



(Etched Foil Dry Electrolytics)

## SPRAGUE ATOMS

A whale of a lot better than you ever thought a small condenser could possibly be made—that, in brief, is the Sprague ATOM! They're better, in fact, than lots of other makes of condensers two or three times their size.

Sprague ATOMS are small enough to fit in anywhere—and believe us, they'll stand the gaff. They're made by an exclusive Sprague etched foil process that puts more real, honest-to-goodness quality per inch into a condenser than has ever been put there before. And don't worry about "blow-ups." There's not a "firecracker" in a car-load.

### HERE'S WHERE YOU SAVE MONEY!

ATOMS are made in a complete line of capacities and voltages including DUAL COMBINATIONS—just the thing for hundreds of inexpensive "duplicate" replacements. And they'll save you money! List price on the 8 mfd. 450 V. Atom is only 60¢. Other capacities priced proportionately low. Sold singly by leading jobbers or in handy kits:



SPRAGUE PRODUCTS CO. North Adams, Mass.

## A FREE BOOK FOR EVERYONE IN RADIO



RADIO-CRAFT brings you all phases of radio—servicing, public address, set construction, electronics, facsimile, etc. Features popular departments as Latest in Radio—New Tubes—Data Sheets—Television—Operating Notes, etc. Over 175 illustrations in every issue. To readers of this announcement we present a SPECIAL OFFER—Seven Months' Subscription to RADIO-CRAFT and a FREE copy of the 64-page 1938 RADIO REFERENCE ANNUAL for One Dollar. New subscribers welcome—old subscribers can extend their present subscription.

Remit ONE DOLLAR by check, money order or stamps for your FREE BOOK and Seven Months' Subscription to RADIO-CRAFT.

**RADIO-CRAFT** 997 HUDSON STREET, NEW YORK, N. Y.

**FREE RADIO CATALOG 1001 BARGAINS**

**NEW 1939 catalog**

Reserve your copy of this NEW 1939 Catalog No. 73-48 NOW. Remarkable values in radios, parts, public address systems, amateur equipment. Don't buy a thing in radio until you get your FREE copy. Send for it today! Use penny postcard.

**WHOLESALE RADIO SERVICE CO., INC.** 104 SIXTH AVENUE, NEW YORK, N. Y.

**CHASSIS — CABINETS PANELS & CANS**

**STANDARD SIZES ON HAND**

**SPECIAL SIZES MADE TO ORDER**

**KORROL RADIO PRODUCTS CO.**

350 Greenwich St. Dept. S-9 New York City



## Short Wave League

At a Directors Meeting held in New York City, New York, in the United States of America, the Short Wave League has elected

**John F. Müller**

a member of this League.

In Witness whereof, this certificate has been officially signed and presented to the above.

*H. W. Infield Sec'y*  
Club Secretary

This handsome certificate is presented FREE to all members of the SHORT WAVE LEAGUE. The full size is 7/4" x 9 1/2". See page 310.

use 11.78 mc. when not operating on this schedule.

**NEW ZEALAND . . .** ZLT4, 11.05 mc., at Wellington, logged at 5:30 a.m., rather late for ZLT4, an "early a.m." signal, while in contact with VLZ, 9.76 mc., Sydney, Australia. Both R7-8 sigs.

## LATE FLASHES

From Ashley Walcott, we learn that China has reorganized its radio service as follows: XTJ, 11.69 mc., XTK, 9.08 mc., at Hankow; XTR, 9.40 mc., and XTS, 11.44 mc., at Swatow; and XTV, 9.48 mc., Canton, phone each other, 4:30-9:30 a.m. XTV uses XRB phoning KVV at 9:15 or 9:30 a.m.

YDB, Socraabaia, Java, 15.30 mc., heard from 1-2 a.m.



Activity on the ham bands has quieted down gradually since the dx contest and not much of dx interest is to be heard these hot days.

We have done very little dial-twisting of recent weeks, and are certainly enjoying our outdoor "fling" in a big way, and hope you all are having a swell time, too!

It is when cooler days come as harbingers

# FOUR NEW 10¢ RADIO BOOKS

**RADIO FANS EVERYWHERE**—these little ten cent text books give you an excellent foundation for the study of radio. They are clearly written, profusely illustrated and contain over 15,000 words in each book. You'll be amazed at the wealth of information these volumes have. They are handy for review or reference books.

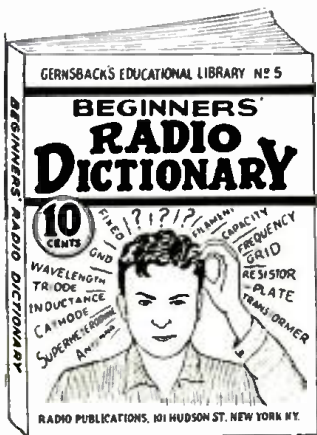

**FAMOUS  
GERNSBACK  
EDUCATIONAL  
LIBRARY**

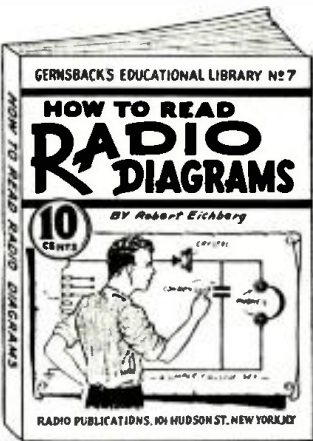

### NO. 5—BEGINNERS' RADIO DICTIONARY

Are you puzzled by radio language? Can you define frequency? Kilocycle? Tetrode? Screen grid? Baffle? If you cannot define these very common radio words and dozens of other, more technical, terms used in all radio magazines and instruction books, you need this book in your library. It's as modern as tomorrow—right up to the minute. It tells you in simple language just what the words that puzzle you really mean. You cannot fully understand the articles you read unless you know what radio terms mean. This is the book that explains the meanings to you. Can you afford to be without it, even one day longer?

### NO. 7—HOW TO READ RADIO DIAGRAMS

All of the symbols commonly used in radio diagrams are presented in this book, together with pictures of the apparatus they represent and explanations giving an easy method to memorize them. This book, by Robert Eichberg, the well known radio writer and member of the editorial staff of RADIO-CRAFT magazine, also contains two dozen picture wiring diagrams and two dozen schematic diagrams of simple radio sets that you can build. Every diagram is completely explained in language which is easily understood by the radio beginner. More advanced radio men will be interested in learning the derivation of diagrams, and the many other interesting facts which this book contains.

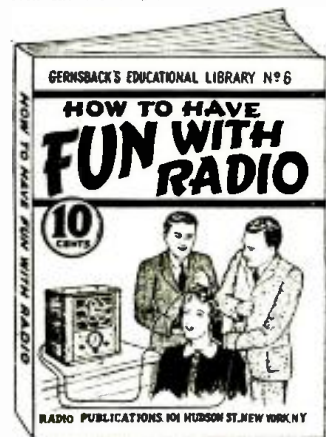

**ADDS  
FOUR  
NEW  
BOOKS!**

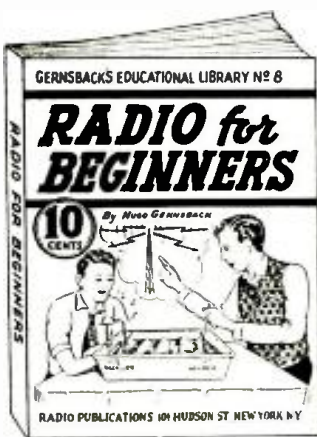

### NO. 6—HOW TO HAVE FUN WITH RADIO

Stunts for parties, practical jokes, scientific experiments and other amusements which can be done with your radio set are explained in this fascinating volume. It tells how to make a newspaper talk—how to produce silent music for dances—how to make visible music—how to make a "silent radio" unit, usable by the deafened—how to make toys which dance to radio music—sixteen clever and amusing stunts in all. Any of these can be done by the novice, and most of them require no more equipment than can be found in the average home. Endless hours of added entertainment will be yours if you follow the instructions given in this lavishly illustrated book.

### NO. 8—RADIO FOR BEGINNERS

Hugo Gernsback, the internationally famous radio pioneer, author and editor, whose magazines, **SHORT WAVE & TELEVISION** and **RADIO-CRAFT** are read by millions, scores another triumph with this new book. Any beginner who reads it will get a thorough ground work in radio theory, clearly explained in simple language, and through the use of many illustrations. Analogies are used to make the mysteries of radio as clear as "2+2 is 4". It also contains diagrams and instructions for building simple radio sets, suitable for the novice. If you want to know how transmitters and receivers work, how radio waves traverse space, and dozens of other interesting facts about this most modern means of communication, this is the book for you!

#### Other Titles in This Series!

- Four other volumes in this ten-cent radio book series—each on a popular subject—are available. The titles are:
- No. 1—HOW TO BUILD 4 DOERLE SHORT-WAVE SETS
  - No. 2—HOW TO MAKE THE MOST POPULAR ALL-WAVE 1- AND 2-TUBE RECEIVERS
  - No. 3—ALTERNATING CURRENT FOR BEGINNERS
  - No. 4—ALL ABOUT AERIALS

#### BOOKS ARE ALL UNIFORM

Every book in the GERNSBACK EDUCATIONAL LIBRARY has 32 pages—with illustrations varying from 30 to 66 in number. Each title volume contains over 15,000 words. Positively radio's greatest book buy! If you do not think these books worth the price asked, return them in 24 hours and your money will be instantly refunded.

**RADIO PUBLICATIONS**  
101 HUDSON STREET NEW YORK, N. Y.

## Let's Listen In with Joe Miller

(Continued from page 305)

true amateur spirit, always willing to help the other fellow!

Paul also adds that he would be pleased to get a "young and smart ham knowing thoroughly all about repairs on receivers that would like to come over here and work partnership with me, here." Paul sez he has quite a lot to do there. Here's a chance for adventure, if any of you OMs are interested.

As regards above Special, that also came too late for publication, sorry.

Other Africans: CN8MA, 14115; CN8AV, 14110; CN8AM, 14100. Max Fisher, es Ye Ed, these in Morocco.

CN8AX, 14300; CN8AN, 14030; CN8AY, 14290, all by Ian Jamieson, England.

Some other Africans reported by Ian: FT4AG, 14310; FT4AK, 14360; FT4AM, 14140, in Tunis.

FA3FB, 14160; FA8QC, 14380; FA8CC, 14280, in Algeria.

VQ4SNB, 14084; VQ4KTB, 14180; in Kenya Colony. ZE1JA, 14320, Southern Rhodesia. SU1MW, 14310, 14120, Egypt. ZS3F, 14105, Southwest Africa, reported by Max Fisher, W6.

That's all for Africa. Now, some European dx:

YU7AY, 14170, Yugoslavia; U3BC, 14100, U.S.S.R.; ZB1L, 14140, Malta; SP1MX, 14040; OK1LV, 14170, OK1SZ,

## Here's Your Button

The illustration shows the beautiful design of the Official Short Wave League button, which is available to everyone who becomes a member of the League. The button measures 3/4 inch in diameter and is inlaid in enamel—3 colors—red, white and blue. The requirements for joining the League are explained in a booklet, copies of which will be mailed upon request.



Please note that you can order your button at once—Short Wave League supplies it at cost, the price, including the mailing, being 35 cents. A solid gold button is furnished for \$2.00 prepaid. Address all communications to **SHORT WAVE LEAGUE, 99-101 Hudson St., New York.**

14300, Czecho-Slovakia; HA1G, 14070, HA1K, 14380, HA2P, 14150, HA6C, 14160, HA7L, 14170, all in Hungary. Also reported, an unusual catch, is CT3AN, on 7090, in the Madeiras. All these reported by Ian Jamieson, who also adds to this imposing list: TF2Z, 7120, Iceland. Two other Maltese fones heard, ZB1T, 14030, and ZB1E, 14370. In Luxembourg, LX1AL, 14040, and LX1TW, 14070.

YR5CF (freq. var.), YR5FP, 14360; YR5BQ, 14090; YR5TI, 14300; YR5PC (L.F.); YR5VV, 14140; YR5KW, 14130; YR5AA (freq. var.), all in Roumania.

All these FB Europeans logged by Ian. Come agn, OB! Also logged was K7AOC, 14150, Alaska.

We hope you'll like this attempt at a column, though admittedly not our best. Please send in any reports on dx to Ye Ed by first of month.

Have you sent for your VAC certificate, at last available? It's a "beaut," es will enhance any wall! We are numbering certificates in order of their issuance, so be one of the VAC pioneers, es get your certificate now, with a low number!

Closing now, CU next month,

JOE MILLER.

### MAIL COUPON TODAY!!

RADIO PUBLICATIONS, Dept. SWT-8-38  
101 HUDSON STREET, NEW YORK, N. Y.

Gentlemen: Please send immediately, **POSTPAID**, the book numbers circled below. I am enclosing....cents—each book being 10c.

1 2 3 4 5 6 7 8

Send FREE listing of 48 new 10c publications.

Name .....

Address .....

City ..... State .....

Remit by check or money order—register letter if you send cash or unused U. S. postage stamps.



# W8XWJ Broadcasts

(Continued from page 271)

was selected, the members of which devote their time exclusively to the operation of W8XWJ. All program material is arranged and produced independently of WWJ.

Programs at W8XWJ are conducted on a four point basis, emphasizing public service, educational features, fine music and spot news. In this last department the station has the valuable assistance of the "Early Bird," the radio-equipped Detroit News plane, and also the big radio field car. With these facilities W8XWJ is amply equipped for spot broadcasts from the scene whenever a big news event breaks.

Many educational and cultural forces have already been linked to the station. From Wayne University and the University of Detroit, lectures and debates are broadcast, as well as plays presented by the colleges' drama departments. Many civic agencies have become part of the broadcasting scheme and the Detroit Board of Commerce has a regular program in which the business affairs of the city are discussed. Fine music is a feature of the programs every afternoon and evening.

In January, when W8XWJ inaugurated its new policy, new studio facilities were added and reception rooms and offices entirely revamped. Its frequency was changed from 31.6 to 41 megacycles. The 100 watt transmitter was replaced by a new 16B transmitter and a 500 watt 88A amplifier, with a frequency response of from 40 to 12,000 cycles. The associated speech input equipment consists of standard type 23B high fidelity broadcast type. A 110A amplifier is also included in the audio.

By means of diversity receiving antennas, two modified communication receivers and a specially designed mixing system, it is possible to feed radio pick-up from the mobile units as well as other sources into the speech system and the transmitter.

Carl H. Wesser, chief engineer of W8XWJ, has been in charge of the station since its inception. His engineering staff includes R. T. Pennebaker, E. J. Kelly and C. E. Leedy. Wellington Granzow is the program director of the station.

This article has been prepared from data supplied by courtesy of Western Electric Co.

## Aerial Mast Made From a Ladder

(Continued from page 287)

in place before the ladder is raised to the vertical position, and these are anchored to stakes or pipes driven into the ground as soon as the mast has been raised.

The foot of the ladder mast may be anchored in any one of several ways. A couple of methods are shown in the picture. The ladder may be a regular factory-built job or it may be home-made and constructed from old material one has on hand. If the ladder is not too long, it can be built from one- by two-inch shingle lath and the steps made from two or three pieces of the same material.—H. W. S.

## NEW CATALOG

● A NEW catalog, listing its complete line of receiving type condensers and giving full technical data and ratings for each one, has been published by Solar. Printed in five colors, the catalog also describes a new capacitor analyzer and resistance bridge.



Tractor Light



Camp Light



Barn Yard Lighting

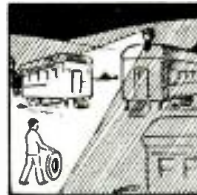

Auto, Truck & Trailer Camp



## U. S. ARMY SIGNAL CORPS LAMP

The Lamp of 100 uses—for day and night scout signaling, night sports and dances, auto, truck and trailer camps, trailers, tractor light, barnyard protection and wherever flood light is desired.

Has a day range of 1 to 6 kilometers and a night range of 3 to 10 kilometers (Note: a kilometer is equivalent to 3,281 feet or 3/5 of a mile). Operated from four dry cell batteries or from a six volt storage battery or from a small bell ringing transformer. May be plugged into any radio set using 6.3 tubes.

Finished in Army Olive Drab Enamel. Has a genuine silver plated reflector—no glass, nothing to break. Packed in a portable wooden carrying case 22 1/2" long, 12" high and 13 1/2" wide, with hinged cover, hump and metal carrying handles. Every case contains weatherproof extension cord and plug, 2 extra bulbs, telegraph signaling on and off contact key and 16 page U. S. Army illustrated Instruction Manual.

Two sizes were used during the war—the large one, made in America; the small one, in France.

Large size—12 1/2" wide, 5 3/4" deep, 15" high including socket, fitted with 10" reflector. Shipping weight 18 lbs. Price, . . . . . \$3.95 (Cost the Government about \$25.00).

Small size—6" wide, 5" deep, 10 3/4" high including socket, fitted with 5" genuine silver plated reflector, no glass, nothing to break. This lamp is furnished with 6 volt bulb for A.C. current. One extra bulb furnished free with each lamp. Additional bulb 15c each. Packed in a corrugated carton. Shipping weight 2 lbs. Price . . . . . \$1.95 (Cost the Government about \$10.00).

These lamps will make an attractive souvenir of the World War for your Club, Motor Boat, House, Den, Radio Shack or Country Home. They will also be an acceptable gift to any of your friends.

**GOLD SHIELD PRODUCTS**  
350 Greenwich St., Dept. S-9 New York City



Scouts Signalling



Night Bowling Alleys



Trailer Lamp



Night Motor Boat Races

Our readers' technical service can supply copies of the catalog. Ask for bulletin 108A. The article has been prepared from data supplied by courtesy of Solar Mfg. Corp.

## Portable 30-Watt Xmitter

(Continued from page 301)

**BUD**  
C13—00035 mmf. variable condenser

- I.R.C. (Resistors)**  
R1—10,000 ohms, 2 watts  
R2—20,000 ohms, 2 watts  
R3—10,000 ohms, 2 watts  
R4—450 ohms, 10 watts  
R5—25 ohms, 1 watt  
R6—25 ohms, 10 watts  
R7—1000 ohms, 2 watts (2 connected in parallel)  
R8—3000 ohms, 20 watts  
R9—5000 ohms, 20 watts  
R10—30,000 ohms, 20 watts  
R11—.25 meg., 1 watt  
R12—1000 ohms, 10 watts  
R13—50,000 ohms, 2 watts  
R14—.5 meg. potentiometer  
R15—1 meg., 1/2 watt  
R16—50,000 ohms, 50 watts

**SANGAMO (Condensers)**  
C2—.00005 mf. mica  
C5—.01 mf. mica

**CARDWELL**  
C12—Dual 100 mmf. variable condenser

- Miscellaneous**  
SW2—SPST toggle switch  
SW3—SPST toggle switch  
SW4—DPST switch  
SW5—SPDT midget knife type switch  
SW6—DPST, band-switching type, 1000 v.  
CH1—modulation choke 20 h. at 200 ma., 300 ohms  
CH2—filter choke, swinging type, 25 to 6 h., 100 to 500 ma., 55 ohms  
T1—Pwr. Transf., 1450 v., c.r. at 250 ma.  
T2—6.3 volts, 3 amp.; 5 volts, 3 amp. filament transformer

**Famous Radio Men Hail the "RADIO AMATEUR" in the October Issue!**

## G.E. PHONOGRAPH MOTOR

Formerly Sold for \$15.00



Only \$4.95

**VARIABLE** speed induction type self-starting, 110 volt, 25 to 60 cycle, A.C. with speed control. Plug and cord. Speed range from 3 to 200 R.P.M. Can be installed in place of old-fashioned, hand-winding speed motor. Also ideal for display turn table, and a hundred other uses. These General Electric Motors are brand new, in original factory cartons. \$4.95 G. E. Electric Phonograph motor as described . . . . .

Shipping Weight—12 lbs.

## MICROPHONE and RECEIVER

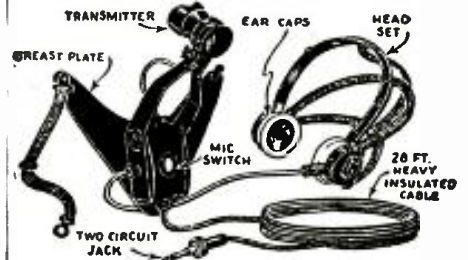

**THIS** Microphone and telephone headset outfit was built especially for the U. S. Navy Aviation Corps. The Holtzer-Cahot Electric Company constructed the outfit to Government specifications. The outfit consists of a low-impedance carbon microphone (transmitter), securely fastened to a metal breast-plate, and a set of heavy-duty, low-impedance earphones. A specially constructed switch on the back of the breast-plate controls the microphone circuit. The earphones are U.S.N. Utah type, attached to adjustable headband. Twenty-eight feet of very heavy weather and waterproof conductor cable is furnished. Current of not more than 10 volts should be used. A storage battery is the most satisfactory current supply. U. S. Navy Airplane-type Microphone and Receiver as described . . . . . \$4.95

Shipping Weight—9 lbs.

We will forward Shipments by Express Collect if sufficient postage is not included.

**WELLWORTH TRADING COMPANY**  
560 W. Washington Blvd., Dept. SWT-938, Chicago, Ill.



# FREE-FIFTEEN OF PUBLICATIONS

featuring construction of the most popular short-wave receivers and transmitters

with a One-Year's Subscription to Short Wave & Television

THESE publications are large printed sheets which average in size about 11"x17", the majority of them printed on both sides. All have photographic reproductions of the complete project, as well as detail illustrations. In addition, there are complete wiring diagrams and various technical details to assist the experimenter and builder in constructing the set. Full Parts lists are always given, and the printed text runs anywhere from 500 to 3,000 words, depending on the complexity of the radio receiver. ALL RECEIVERS AND TRANSMITTERS ARE STRICTLY UP-TO-DATE: THERE ARE NO ANTIQUES OR OUT-OF-DATE PUBLICATIONS IN THIS

LIST. These projects are particularly valuable to the experimenter and constructor who builds "his own". Indeed, the 50 publications shown on this page represent the cream of recent radio construction by the master radio builders of America. Designs of this kind usually are sold for 25c to \$1.00 apiece, and frequently you do not get half the technical information we give you. When mailing us your subscription, use the special coupon on this page. Select your 15 projects by their serial numbers. We accept money orders, cash, checks or new U.S. stamps (no foreign stamps or currency accepted). If you send cash or stamps register your letter against possible loss.

**JUST LAST MONTH, THESE 15 PROJECTS, IF BOUGHT SINGLY, WOULD COST YOU \$1.50. YOU CAN NOW GET THEM ABSOLUTELY FREE!**

**HOW TO BUILD THE SWITCH BAND-2 RECEIVER.** A low-cost receiver for 6 volt battery or A.C. operation which enables the short-wave fan to hear stations in all parts of the world.....No. 1

**HOW TO MAKE A 2-TUBE RECEIVER FOR THE BEGINNER.** This receiver consists of detector and two audio stages. A double purpose tube is used to secure the 2 audio stages. Tubes are for 1½ volt battery operation.....No. 2

**HOW TO MAKE THE PORTABLE SUPERHET 4.** An ace all-wave superhet for battery operation. This receiver features band-spread and has a built-in beat oscillator.....No. 3

**HOW TO BUILD A 4-BAND 3-TUBE SUPERHET.** A 3-tube receiver giving 4-tube results. Back and panel type construction is employed. It has a regenerative second detector.....No. 4

**HOW TO MAKE A FIXED-BAND 8-TUBE SUPERHET.** This short-wave "fan" receiver tunes over a wide band of frequencies without coil switching or changing. It's a real performer. It operates directly from 110 V. A.C. and has band-spread.....No. 5

**HOW TO BUILD A 5-TUBE SUPERHET FOR FAN AND HAM.** A sure-fire receiver for all short-wave enthusiasts. It uses plug-in coils and iron core I.F. transformers which assure plenty of gain.....No. 6

**HOW TO MAKE A TWIN-PENTODE RECEIVER.** This receiver, especially designed for the beginner, employs but one dual purpose tube which gives results equivalent to a 2-tube receiver. It is for 2-volt battery operation with headphones.....No. 7

**HOW TO BUILD AN EFFECTIVE SHORT WAVE PREELECTOR.** A signal-booster that will greatly improve reception on any short-wave super. It employs two 6K7 tubes in parallel in a highly efficient circuit in which both input and output are tuned.....No. 8

**HOW TO BUILD A REGENERATIVE 2-TUBER.** This unusual receiver has the tickler coil in the screen grid circuit of the detector. The receiver tunes from 9-270 meters; band-spread is included; metal or glass tubes may be employed.....No. 9

**HOW TO MAKE THE S.W.A.T. COMMUNICATIONS RECEIVER.** An unusually fine receiver for the critical Ham and Fan, incorporating many exceptional features. Regeneration is employed in the first detector stage which makes use of an acorn tube. The receiver also incorporates a noise-control circuit, variable selectivity control and a tuning meter.....No. 10

**HOW TO MAKE A BAND-SWITCHING 2-VOLT RECEIVER.** This receiver for battery operation employs a band-switching arrangement, enabling the builder to tune from 16-550 meters by flipping a switch.....No. 11

**HOW TO BUILD THE MULTI-BAND 2 RECEIVER.** A receiver for the short-wave beginner. It has a remarkable tuning range of 2½-270 meters with hand-spread on all bands. Plug-in coils are used and complete data for an A.C. power supply is given.....No. 12

**HOW TO MAKE THE VS-5 METAL TUBE SUPERHET.** This complete all-wave receiver boasts, among other things, variable selectivity, metal tubes, AVC and band-spread. The tuning range is from 17-550 meters.....No. 13

**HOW TO BUILD A BEGINNERS 2-TUBE SUPER.** A simplified superhet using 2 volt battery tubes which is just the thing for the beginner. It employs plug-in coils which cover a tuning range from 15-200 meters.....No. 14

**HOW TO MAKE A T.R.F.-3 FAN RECEIVER.** This is an all-around receiver employing 2 volt tubes. A T.R.F. stage ahead of the regenerative detector insures good selectivity and sensitivity. Band-spread is provided by a two-speed dial.....No. 15

**HOW TO BUILD THE FORTY-NINER-A RECEIVER FOR LEAN PURSES.** This novel receiver features a space-charge detector and requires only 12 volts of B battery. It uses 2-49 tubes which may be operated from any 2 volt A battery.....No. 16

**HOW TO MAKE A REAL 5-METER SUPERHET.** This carefully designed receiver for ultra-short wave reception employs a straightforward circuit. Careful placement and high quality parts insure fine results.....No. 17

**HOW TO BUILD THE 2-VOLT SUPER DX-4.** This superhet, though small in size is big in performance. Using battery type tubes, it features continuous band-spread, and automatic volume control, which may be cut in or out as desired.....No. 18

**HOW TO MAKE THE ULTRA-HIGH FREQUENCY WIZARD-6.** This is a first-class 5-meter super-regenerative receiver, using acorn tubes in the B.F. and detector stages. The other tubes are of the metal type. The use of the acorn tubes insures exceptionally fine results.....No. 19

**HOW TO BUILD A HIGH-GAIN METAL-TUBE RECEIVER.** This little receiver is a real performer, tuning from 10-200 meters. Continuous band-spread is provided.....No. 20

**HOW TO BUILD THE WORLD-WIDE 10-METER CONVERTER.** Many enthusiastic reports have been received from the builders of this unit, which may be attached to your present receiver for picking up 10 meter signals from all parts of the world. Only 2-tubes are used.....No. 21

**HOW TO BUILD A DE LUXE 3-TUBER.** This is the receiver for the Ham or Fan who wants a really high class receiver of simple design. It employs an unusual band-spreading dial. The circuit, employing metal tubes, has a stage of T.I.F.F. followed by a regenerative detector and a stage of audio.....No. 22

**HOW TO BUILD THE OCTOGE METAL TUBE-3.** This receiver is capable of excellent performance on the short waves. It requires only one plug-in coil for each band as a stage of untuned I.F. Precedes the detector. It also has an A.F. stage for boosting the volume to comfortable headphone level.....No. 23

**HOW TO MAKE THE 3-IN-1 REFLEX SET.** A 2-tuber giving 4-tube performance is this receiver which does its work with a minimum of tubes. A 6F7 is used as a combined I.F. amplifier, detector and first audio stage; a 6C5 is used as second audio stage.....No. 24

**HOW TO BUILD THE 100 WATT QRM DODGER—A COMPACT 5-METER TRANSMITTER.** This M.O.P.A. rig puts out a hefty signal and by use of a calibrated vernier oscillator control will overcome the QRM problem on 5 meters.....No. 25

**HOW TO BUILD A DE LUXE 5-METER MOBILE STATION.** A really fine M.O.P.A. mobile transmitter which will work real DX on portable location. It employs five metal tubes.....No. 26

**HOW TO BUILD THE H-G-M MEDIUM POWER TRANSMITTER.** A crystal control set with an output of 90 watts. Band-switching is employed for operation on the 80, 40, 20 and 10 meter Ham bands. It gave excellent results under test.....No. 27

**HOW TO MAKE THE 806 ALL-BAND TRANSMITTER.** An unusual transmitter delivering 400 watts output from an 806 final amplifier. A crystal pen-tet oscillator is used, followed by a driver stage. Real DX has been worked on 10, 20, 40 and 80 meters with this smooth working job.....No. 28

**HOW TO BUILD A 125-WATT MOODULATOR USING 35T's.** This is an ideal unit for the amateur and will modulate any transmitter with a power input up to about 400 watts. A total of 10 tubes are used including the power supply unit.....No. 29

**HOW TO BUILD THE C-O-M 150 WATT TRANSMITTER.** An unusual crystal oscillator, multiplier with but one tuned circuit. It uses a pair of RK37's in parallel with a RK39 driver. The crystal oscillator circuit uses a 6L6.....No. 30

**A LONG-LINES TRANSMITTER FOR 1-METER TRANSMISSION, AND A COMPANION RECEIVER.** A really special job for the seriously minded experimenter. This outfit permits short distance contacts in this interesting band.....No. 31

**HOW TO BUILD A 200 WATT XMITTER WITH PEN-TET EXCITER.** This transmitter will really go to town. The use of the Pen-Tet crystal oscillator and frequency multiplier circuit eliminates many headaches from cracked crystals.....No. 32

**HOW TO BUILD A 10 AND 20 METER TRANSMITTER.** A 200 watt transmitter which worked world-wide DX on test. Although compact, it is highly efficient in the 10 and 20 meter bands. Five tubes are used.....No. 33

**HOW TO MAKE THE WIZARD 1-TUBE 50-WATT TRANSMITTER.** An amateur, crystal-controlled c.w. transmitter using the RK20 screen grid pentode. In tests, it compares with 250-watters.....No. 34

**HOW TO MAKE THE "OSCILLODYNE" 1 TUBE WONDER SET.** One of the most sensitive short-wave sets designed, employing a really new circuit for the first time. Battery operated.....No. 35

**HOW TO MAKE THE "IS" TWINPLEX (ONE TUBE PERFORMS AS TWO) RECEIVER.** One of the most sensitive 1-tube sets ever designed and very popular.....No. 36

**HOW TO MAKE THE IMPROVED 3-TUBE DOERLE SET FOR BATTERY OPERATION.** One of the finest of the Doerle series, by the famous short-wave inventor.....No. 37

**HOW TO MAKE THE "GO-GET-'EM 2" RECEIVER FOR THE BEGINNER.** This unusual 2-tube circuit gives 3-tube results. Battery operated. Excellent for beginners.....No. 38

**HOW TO MAKE THE 1-TUBE ALL-ELECTRIC OSCILLODYNE.** This is the famous electrified short-wave receiver. Easy to build for little money. Operates on A.C. and D.C.....No. 39

**HOW TO MAKE THE 2 TO 5 METER TWO-TUBE LOUDSPEAKER SET.** This receiver may be used with batteries or with an A.C. power pack. Packs a big wallop.....No. 40

**HOW TO MAKE THE 3-TUBE BATTERY SHORT-WAVE RECEIVER.** This receiver was a prize winner in SHORT WAVE CRAFT. An unusual short-wave receiver, easy to build.....No. 41

**THE BRIEF-CASE SHORT-WAVE RECEIVER AND HOW TO BUILD IT.** So small that the entire set, batteries, head set, aerial and everything, goes into a briefcase. Stations from Europe are often received. By Hugo Gernsback and Clifford E. Denton.....No. 42

**HOW TO BUILD THE POCKET SHORT-WAVE RECEIVER.** One of the smallest, pocket-size, battery receivers ever designed by Hugo Gernsback and Clifford E. Denton. A marvelous set that brings in European stations.....No. 43

**HOW TO BUILD THE CIGAR-BOX 1-TUBE "CATCH ALL" RECEIVER.** An effective short-wave battery set which fits into a small cigar box, insuring high portability yet great efficiency.....No. 44

**HOW TO BUILD THE "DUAL-WAVE" SHORT-WAVE BATTERY RECEIVER.** With this set, you can hear both ends of radiophone talk on one set of phones. In other words, you can listen to a ship at sea and the land station communicating with it, simultaneously, by means of this double receiver.....No. 45

**HOW TO BUILD THE 1-TUBE "53" TWINPLEX RECEIVER.** The twinplex, although it has only one tube, works as if it had two. Marvellous in efficiency. Uses either batteries or A.C. power pack for "B" supply.....No. 46

**HOW TO BUILD THE PORTABLE MINIDYNE SHORT-WAVE BATTERY SET.** Uses no aerial, no ground. The total weight is 3½ lbs. and measures 5x5x6 inches. Self-contained batteries, tube, condensers and loop. Highly sensitive circuit.....No. 47

**HOW TO BUILD THE HAM-BAND "PEE-WEE" 2-TUBER.** A dandy receiver with high efficiency and band-spread tuning. Works a loudspeaker, yet the entire receiver is no larger than your hand. Works with either batteries or an A.C. power pack.....No. 48

**HOW TO BUILD THE DUO-AMPLIDYNE.** The ideal 1-tube set for the beginner. One of the finest 1-tube sets; it really gives 2-tube performance. Made for battery operation. With only ten-foot antenna brings in the good European stations.....No. 49

**HOW TO BUILD THE "MONO-COIL 2".** No more "plug in" coils. This set eliminates bothersome coils and is made to cover short-wave bands. Works with either batteries or A.C. power pack.....No. 50

## SHORT WAVE & TELEVISION, 99 Hudson Street, New York, N. Y.

Gentlemen: Enclosed you will find my remittance of \$2.50 for which enter my subscription to SHORT WAVE AND TELEVISION for One Year (12 issues). Send me promptly, absolutely FREE and POSTPAID, the 15 publications I have marked at the right. (CANADIAN AND FOREIGN \$3.15.)

NEW SUBSCRIBER  EXTEND PRESENT SUBSCRIPTION

Name .....

Address .....

City .....

State .....

Send remittance by check or money order. Register letter if you send cash or unused U. S. Postage Stamps

1	2	3	4	5
6	7	8	9	10
11	12	13	14	15
16	17	18	19	20
21	22	23	24	25
26	27	28	29	30
31	32	33	34	35
36	37	38	39	40
41	42	43	44	45
46	47	48	49	50



# A Beat-Frequency Oscillator

(Continued from page 295)

voltage, lighting the filament of the 25A7G and turning on the receiver. Switch SW-2 turns on the "bfo" itself whenever it is needed.

With all parts mounted as shown in the photo, the two switches are close enough to the socket, so that the socket terminals can be bent over and the two terminals that connect to the switches will just reach the switch terminals, thus eliminating any wire between them. An insulated strip, having three lugs, serves as junction points for the 5000 ohm resistors and also to keep the circuit ground away from the chassis. By keeping the chassis insulated from the "bfo" circuit, there is no danger of blowing fuses, which could happen if the chassis were connected to ground and the line plug reversed on d.c. or with the grounded side of the a.c. line connected to the plate of the rectifier section of the 25A7G. This necessitates the use of a ground to the chassis in order to obviate any body capacity effects. A wire from the receiver chassis to the "bfo" chassis will suffice. Many users will probably fasten the "bfo" directly to the receiver chassis, in which case the wire connection between the two chassis will be unnecessary.

As mentioned previously, the line cord comes with a built-in dropping resistor and it should be made certain that it has a value of 300 ohms. A word of warning concerning the resistor cord—since the resistance is distributed along the entire length of the line cord, the line cord must not be cut in order to shorten it; the entire length must be used. In operation it will be warm, but not too hot to touch. Try to keep it in a ventilated place. The resistor cord comes with three leads. The heavier lead is the resistor lead and connects to one side of the filament of the 25A7G. The other two leads are connections from the line plug, the black lead coming from the same prong of the plug as the series resistor and the red lead connecting to the other side of the line. This red lead, through switch SW-2, connects to the other side of the filament.

## Connection of the Oscillator to Receiver

When wired, the unit is ready for installation and adjustment. The resistor cord is plugged into the 110 volt line and receiver line cord is plugged into the receptacle provided on the "bfo" unit. If the receiver switch is left on the "ON" position, switch SW-1 will turn on the receiver and light the 25A7G filament. A lead should be provided from the plate of the 25A7G through the 50 mmf. mica condenser. Incidentally, this might well be of the adjustable trimmer type, although not strictly necessary. If adjustable, it might prove advantageous to vary the coupling between the "bfo" and the receiver. However, this unit is not at all critical with respect to coupling. This lead feeds the beat oscillator frequency into the receiver and can be connected to one of several places. The simplest way is to remove the grid cap of the first i.f. tube and wind the insulated feed wire several times around the grid cap, making sure the wire itself does not make contact with the grid. The grid cap is then replaced. The lead should not be allowed to go near the receiver high frequency oscillator, or there will be some detuning of the receiver, resulting in its calibration being shifted.

A more satisfactory method of coupling would be to connect the "bfo" lead to the

# RADIO'S MANY NEW BOOKS HAVE BEEN ADDED TO MOST COMPLETE LOW-PRICED TECHNICAL LIBRARY



THE RADIO-CRAFT LIBRARY SERIES (each volume fifty cents)—a most complete and authentic set of Volumes—treats individually, important divisions of radio, refrigeration and air conditioning. Each book has been designed to give you the opportunity to learn one or more branches of the fields mentioned. The authors of the books are well-known to everyone. Each is an expert—an authority on the subject—each is thoroughly familiar with the field which he represents.

ALL BOOKS ARE UNIFORM—The volumes in the RADIO-CRAFT LIBRARY SERIES measure 6 x 9 inches. Each book contains on an average of 50 to 120 illustrations. The books are printed on an excellent grade of paper which makes the type easy reading.

## Here Are the Titles - - -

- |  |   |  |
|--|---|--|
| No. 2. MODERN VACUUM TUBES               | No. 12. PUBLIC ADDRESS INSTALLATION AND SERVICE | No. 17. SERVICING WITH SET ANALYZERS       |
| No. 3. THE SUPER-HETERODYNE BOOK         | No. 13. ABC OF AIR CONDITIONING                 | No. 18. POINT-TO-POINT RESISTANCE ANALYSIS |
| No. 4. BRINGING ELECTRIC SETS UP-TO-DATE | No. 14. POCKET RADIO GUIDE                      | No. 20. THE CATHODE-RAY OSCILLOSCOPE       |
| No. 9. AUTOMOBILE RADIO AND SERVICING    | No. 15. ABC OF REFRIGERATION                    | No. 21. BREAKING INTO RADIO SERVICING      |
| No. 10. HOME RECORDING AND ALL ABOUT IT  | No. 16. PRACTICAL RADIO CIRCUITS                |  |

## RADIO PUBLICATIONS • SWT 9-38 • 39T Hudson Street, • New York, N. Y.

I have circled below the numbers of books in the RADIO-CRAFT LIBRARY SERIES which you are to send me. I have included my remittance in full, at the price of 50c each. (Stamps, checks or money orders accepted).

2 3 6 9 10 12 13 14 15 16 17 18 20 21

Name ..... Address .....

City ..... State .....

All books are sent postage prepaid

grid terminal of the last i.f. transformer. A direct connection is not necessary. The beat-freq. oscillator lead is merely twisted half a dozen times around the lead in the receiver which goes from the grid terminal of the last i.f. transformer to the grid of the detector tube, if a triode is used. If the receiver employs a diode second detector, the i.f. transformer will be connected to the diode plate.

Once the beat-freq. oscillator is connected, it is ready for its adjustment. A short-wave broadcast station is tuned in on the receiver. Next the "bfo" switch SW-2 is turned on. This applies plate voltage to the oscillator, which will generate a signal whose frequency will depend on the setting of the trimmer condenser on the "bfo" transformer. This trimmer should now be adjusted so that the frequency generated by the "bfo" differs from the receiver intermediate frequency by approximately 1000 cycles. Slowly adjust the trimmer, using an insulated screwdriver, until a squeal as loud as the broadcast station signal is heard. The broadcast station will then become unintelligible. For a closer adjustment of the trimmer—with the "bfo" on, a c.w. telegraph station should be tuned in and the trimmer very slowly varied for the most pleasing tone.

## Parts List

- I.R.C.**  
 2—5000 ohm, ½ watt resistors  
 1—25,000 ohm, ½ watt resistor  
 1—50,000 ohm, ½ watt resistor
- HAMMARLUND**  
 1—BFO transformer (STBO-465)  
 1—Octal socket
- AEROVOX**  
 1—4 x 4 mf. 250 v. electrolytic (type PBS) condenser  
 1—.0005 mf. mica condenser  
 1—.00005 mf. mica condenser  
 1—.1 mf. 200 v. paper condenser
- RCA**  
 1—25A7G tube
- KORROL**  
 1—chassis 6" x 3" x 1½"
- MISCELLANEOUS**  
 2—SPST toggle switches  
 1—300 ohm resistor line cord  
 1—female AC receptacle

# DATAPRINTS

Only 33½c each  
 in orders of 3 at \$1

BUILD YOUR OWN—SAVE MONEY!



RADIO CONTROL FOR MODEL BOATS, PLANES, ETC.

Circuit data ..... 50c

20 ELECTRIC LODGE & PARTY TRICKS. Fun Galore!

"How to Do 'Em" Data 50c



S-W DIATHERMY (Artificial Fever)

Dataprint giving Constructional data for Small, Medium and Large size APP. (All 3).... 50c

Induction PIPE & ORE LOCATOR

Construction Data..... 50c



RECORD VOICE OR CODE on Steel Wire!

Telephone Data, for Voice or Code..... 50c

## TESLA COIL DATA:

- Data print—drawings and data for building 36-inch apart Tesla... 50c  
 Exciter—1 k.w. 20,000 Vt. Transf. 50c  
 3" Sp.k. Tesla Coil. Works on Ford Coil 50c  
 3" Sp.k. Oudin Coil. Works on 110 A.C. 50c  
 20 "Tricks" with Teslas & Oudins 50c  
 8" Sp.k. Tesla Coil 50c  
 Exciter—½ k.w. 15,000 Volt Transf. 50c  
 Violetta—1" Sp.k. Oudin, Vibrator type 50c  
 How to Operate Oudins from V. T. Osc. 50c



## More DATAPRINTS You Need!

- Water Turbines "Rewinding" Armatures  
 Water Wheels Induction Balance  
 100 Mechanical Movements Telautograph  
 Motor (Fruits) (20) Eindhoven String Galvanometer  
 Telephone Hookups (20) Magnets and Solenoids—Get our list  
 Polarized Relay. Ultra-sensitive Wheatstone Bridge  
 Ring 4 bells on 2 wires Induction Coils—1 to 12  
 20 Simple Bell Hook-ups inch Spk data  
 Electric Chime Ringer fits any clock Electric Pipe Thawer  
 Welding Trf. 2 k.w. 110 V. Prim. 18 V. Sec.... 50c  
 5 prints \$1.50 or 10 for \$2.00; single prints 50c

The DATAPRINT Co.

Lock Box 322 RAMSEY, N. J.

All about the  
**SHORT WAVE LEAGUE**

**A FEW WORDS AS TO THE PURPOSE OF THE LEAGUE**

The **SHORT WAVE LEAGUE** was founded in 1930. Honorary Directors are as follows:

Dr. Lee de Forest, John L. Reinartz, D. E. Replugie, Hollis Baird, E. T. Somerset, Baron Manfred von Ardenne, Hugo Gernsback, Executive Secretary.

The **SHORT WAVE LEAGUE** is a scientific membership organization for the promotion of the short wave art. There are no dues, no fees, no initiations, in connection with the **LEAGUE**. No one makes any money from it; no one derives any salary. The only income which the **LEAGUE** has is from its short wave essentials. A pamphlet setting forth the **LEAGUE'S** numerous aspirations and purposes will be sent to anyone on receipt of a 3c stamp to cover postage.

**FREE MEMBERSHIP CERTIFICATE**

As soon as you are enrolled as a member, a beautiful certificate with the **LEAGUE'S** seal will be sent to you, provided 10c in stamps or coin is sent for mailing charges.

Members are entitled to preferential discounts when buying radio merchandise from numerous firms who have agreed to allow lower prices to all **SHORT WAVE LEAGUE** members.

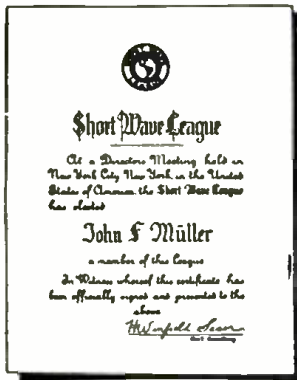

If you wish your name engraved on the Free membership certificate, as illustrated above, please send 25c to cover cost.

**SHORT WAVE ESSENTIALS LISTED IN OPPOSITE COLUMN SOLD ONLY TO SHORT WAVE LEAGUE MEMBERS**

They cannot be bought by anyone unless he has already enrolled as one of the members of the **SHORT WAVE LEAGUE** or signs the blank below (which automatically enrolls him as a member, always provided that he is a short wave experimenter, a short wave fan, radio engineer, radio student, etc.).

Inasmuch as the **LEAGUE** is international, it makes no difference whether you are a citizen of the United States or any other country. The **LEAGUE** is open to all.

**Application for Membership SHORT WAVE LEAGUE**

**SHORT WAVE LEAGUE** 9-38  
99-101 Hudson Street, New York, N. Y.

I, the undersigned, herewith desire to apply for membership in the **SHORT WAVE LEAGUE**. In joining the **LEAGUE** I understand that I am not assessed for membership and that there are no dues and no fees of any kind. I pledge myself to abide by all the rules and regulations of the **SHORT WAVE LEAGUE**, which rules you are to send to me on receipt of this application.

I consider myself belonging to the following class (put an X in correct space): Short Wave Experimenter  Short Wave Fan  Radio Engineer  Student

I own the following radio equipment:

Transmitting .....  
Call Letters .....  
Receiving .....  
Name .....  
Address .....  
City and State .....  
Country .....

I enclose 10c for postage and handling for my Membership Certificate.

**Practical Antenna Theory and Application**

(Continued from page 269)

The open wire type is the most popular among amateurs because of simplicity and cost.

For an efficient working line it must have these characteristics: A low ohmic resistance such as given by copper, mechanical rigidity, and strength; and must be so placed as to avoid coming into contact with any grounded object. In order for the line to function properly electrically, it must be balanced to ground, must have a minimum of leakage across the supporting units spacing the wires and should not have any appreciable standing waves. To acquire that condition, it is necessary to match your line to the radiation impedance of your antenna. It is assumed that the average antenna has a radiating resistance of about 75 ohms.

**Surge Impedance**

A line having a length of more than one or two wave-lengths of the antenna, has what is known as a characteristic or *surge impedance*, whose value is determined by the ratio of inductance to capacity per unit length of the line. In other words, the characteristic impedance of the line is a function of both inductance and capacity.

Both the capacity and the inductance is determined by the physical components of the line such as the size of the conductors and the spacing between them, when working at high frequencies. For maximum power transfer to the antenna through this line, it is important that the line meets with the following requirements.

It is of greatest importance that the line be properly terminated, or matched with the impedance that it is working into. Now that can be accomplished several ways (9 methods, see diagrams). However, line impedances can be calculated to save time and material. For instance, the formula for a two-wire line having air as the dielectric is Z; the impedance of the line, is equal to the constant 277 x log 10 of twice the separation distance of the wires, divided by the diameter of the wire in inches or millimeters;

$$Z = 277 \times \log_{10} \frac{2S}{D}$$

(S and D being expressed of course in the same terms, i.e., either inches or mm.)

Here are a list of wires generally used with different spacing, providing various characteristic impedance values:

Wire Size B&S	Spacing of wires in inches					
	2	3	4	5	6	
Surge impedance of wires	in ohms					
No. 14	500	550	575	600	625	
No. 12	475	510	550	575	600	
No. 10	440	490	520	550	575	

Note that a line made up of No. 10 B&S copper wire spaced 2" apart has an impedance of 440 ohms. Also note that your antenna has an impedance of only 75 ohms at center. You can readily see that some means must be employed to bring the line impedance down to the antenna resistance. One of several methods are herein described. If your line was connected directly to your antenna without matching you would get a loss of over 3 db., representing a total loss of 50% or more of your energy in your transmitter. You certainly would not tolerate that if you were

aware of it. This is figured by the ratio of voltage in-put to voltage out-put. Then you would have standing waves on your feeder line to further increase your losses and hinder proper power radiation from your antenna system.

It is possible to construct a line with a twisted pair of wires with some form of insulation that is a solid dielectric, but that method introduces too much loss in the line. Then the line can be made exactly 1/2 wave-length or some multiple of a half wave-length and due to the standing wave on the line, would make the in-put impedance of the line appear to be 75 ohms, regardless of the surge impedance of such a line.

This type of feeder is not very efficient, because the actual power lost in the line itself is considerably higher than the mismatched condition of direct-connected line to antenna.

The job of making the line length an integral multiple of the fundamental of the antenna is not an easy one either.

The most practical method both from a mechanical and electrical standpoint is where you use some form of energy transfer device, such as a Pickard transformer for coupling the current point of the antenna to the line by a step-down of current ratio (see diagrams) or the application of the "Y" connected feeder system. The "Y"

LINE RADIATION IS PROPORTIONAL TO THE SQUARE OF THE SPACING. CONDUCTORS SPACED 2" APART WILL RADIATE ONLY ONE-NINTH AS MUCH AS THOSE SPACED SIX INCHES APART (SEE FIG 4A)

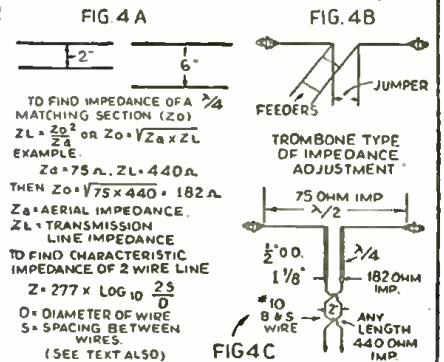

FORMULA FOR CONCENTRIC LINE.  $Z0 = 138 \times \log \frac{b}{a}$

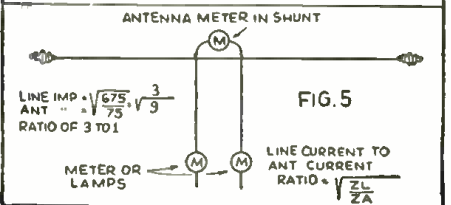
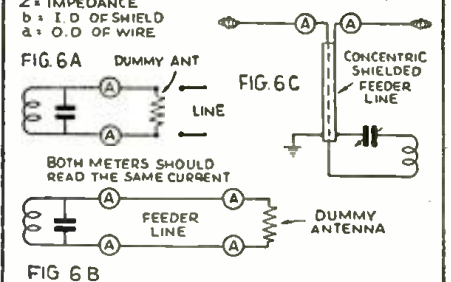

Further details of "Ham" aerials described by the author.



connected system makes use of the fact that somewhere along the antenna, starting at the center, which has an impedance of 75 ohms, there must be a point from that center that has a similar value of impedance to that of the line feeding it. That is due to the current and voltage relation being different because of standing waves on the antenna itself. Then by attaching the feeders at that point we should find a place that would be suitable as a proper matching position for the feeder line, and thereby obtain the condition where the feeder for the antenna works into the correct impedance relation.

Reasons for terminating line to its characteristic impedance:

1. It makes the line impedance independent of frequency and line length.
2. It makes the transfer of power from generator to load with the highest possible efficiency.

Zepp

A Zepp feeder has a high impedance.

The line is cut to an odd quarter-wave and acts simultaneously as a feeder and matching transformer, feeding the antenna with a high voltage and low current, while taking a high current and a low voltage from the transmitter.

Transposed feeders have the advantage of symmetrical electrical layout, such as even distribution of capacity to ground.

All three dimensions must be correct for proper power transmission.

Adjustment of plate tank coupling regulates impedance match of power to line for proper loading. (See fig. 3-B.)

This antenna system (see fig. 3-C) is adjusted by a  $\frac{1}{4}$  wave section that terminates the feeder line, this adjustment being made to match up with the "characteristic" impedance of the line used. For instance: No. 10 B&S wire spaced 2" apart has an impedance of 440 ohms. The proper termination of the line to antenna through the  $\frac{1}{4}$  wave section for a 75 ohm antenna impedance, would be 182 ohms characteristic impedance of the  $\frac{1}{4}$  wave section.

## Short-Wave League

(Continued from page 275)

reception and transmission at the high frequencies.

Short Wave Listeners' reports may be sent to G. A. Clayton, Winscombe, Somerset, England. Accurate and useful reports will be answered with a special QSL card. No reply postage needs to be included. Your reports should contain the following:—Time (in terms of G.M.T. or E.S.T.), R.S.T., type of QSB (if any), working conditions, phase distortion, type of receiver used, and details of the antenna used. Send reports on reception of G6BW, G6VK and GM6RG to the above address. Send reports of others to the stations themselves.

The following stations are co-operating in these test transmissions:—

WIDKQ, W1KTF, W1JTG, W2GO, W2GHU, W2JKQ, W2AZB, W2JAS, W2JAB, W2JCY, W3CBT, W3EOZ, W3FIL, W3GSV, W3GZN, W4CDG, W4CYB, W4CYU, W4EDD, W4EPX, W5EB, W6NLS, W6NCR, W8DST, W8AHC, W8LUQ, VE1BR, VE2CP, XE1GE, TI2FG, CO7CX, K6MVV, H17G, H13N, YV1AP, VK3KX, SV1CA, K4FKC, E15F, E18J, E19J, G2ZV, G5BM.

Transmissions are sent out daily at the following times which are Eastern Standard:—

Sundays—5 a.m., 7 a.m., 9 a.m., 11 a.m., 1 p.m., 5 p.m.  
 Mondays—7:30 a.m., 8:30 a.m., 10 a.m., 1 p.m.  
 Tuesdays—7:30 a.m., 8:30 a.m., 10 a.m., 1 p.m., 4 p.m.  
 Wednesdays—7:30 a.m.  
 Thursdays—7:30 a.m., 8:30 a.m., 10 a.m., 1 p.m., 5 p.m.  
 Fridays—7:30 a.m., 8:30 a.m., 10 a.m., 1 p.m., 3 p.m.  
 Saturdays—9 a.m., 11 a.m., 1 p.m., 3 p.m.

So let's see if we cannot give these tests some help. The transmissions will all be on the 10-meter amateur band between 28.268 megacycles and 28.460 megacycles. Be sure to make your reports complete. They are of little or no use if they are not.

Every observer is urged to send in a

photograph of his post and of himself. Each month the best ones will be printed and all of them if possible. This month the post of Robert Hatcher of Richmond, Virginia, has been selected.

Although it is heard on a broadcast band and not an amateur phone, T12NRH is as interesting as most hams. This station has just recently celebrated its tenth anniversary. A special certificate (see July issue) was issued to all who reported correctly reception of this station. The regular verification certificate is shown on this page. It is nine by twelve inches and printed in red and blue on white paper. It is certainly worth the time and cost of the international reply coupon to obtain one. The one shown here is through the cooperation of Sergeant Douglas S. Catchim, Listening Post Observer for the State of Virginia.

The reports of several more observers could be used, especially in the south-western part of our country. Send your applications for appointment to Elmer R. Fuller, 32 Madison Street, Cortland, New York.

## What's Wrong With Our S-W Broadcasting?

(Continued from page 265)

over or under modulation. Any listener can verify these facts for himself. On the other hand, the European stations pay more attention to technical perfection with happier results for the listener. About the only claim to fame American short-wave broadcasting has is in the number of different stations there are on the air—about 11 in the United States—several of which can operate on 2 frequencies simultaneously. The trouble arises from the fact that s.w. stations are a financial liability rather than an asset to most station operators. Yet the station operators will not admit this fact, as it might be an opening wedge for government operation of s.w. broadcasting, which could easily lead to government operation of all broadcasting. With the politicians in control of broadcasting it would probably be necessary to make it a criminal offense *not* to listen to the radio. Otherwise most people would junk their radios and run (not walk) for the nearest movie.

## Accessories for Members of the SHORT WAVE LEAGUE

Every member of the SHORT WAVE LEAGUE wants to identify himself in some way. For your convenience the League directors have prepared suitable letterheads, label buttons, stickers, etc. In addition there are many short-wave accessories, such as maps, globes, etc. which the League offers only to members at special prices. Take your choice from this advertisement. THESE ESSENTIALS ARE SOLD ONLY TO LEAGUE MEMBERS.



**LEAGUE LETTERHEADS**  
 A beautiful, official letterhead has been designed for members' correspondence. The letterhead is invaluable when it becomes necessary to deal with the radio industry, mail order houses and radio manufacturers, as many houses offer members of the LEAGUE preferential discount. The letterhead is also absolutely essential when writing for verification to radio stations either here or abroad. It automatically gives you a professional standing.

A—SHORT WAVE LEAGUE letterheads, 50c per 100

### WORLD GLOBE

This important essential is an ornament for every den of study. It is a globe, 6 in. in diameter, printed in fifteen colors, glazed in such a way that it can be washed. This globe helps you to intelligently log foreign stations. The base is of solid walnut, and the semi-meridian of a nickel-like metal. Entire device substantially made, and will give an attractive appearance to every station, emphasizing the long-distance work of the operator.



D—Globe of the World 89c Prepaid D—89c each

### SHORT WAVE MAP OF THE WORLD

This beautiful map, measuring 18x26 in. and printed in 18 colors is indispensable when hung in sight or placed "under the glass" on the table or wall of the short wave enthusiast. It contains a wealth of information such as distances to all parts of the world, political nature of the country in which a broadcast station is located, etc., and from the manner in which the map is blocked off gives the time in different parts of the world at a glance.



F—SHORT WAVE Map of the World....Prepaid 25c

### WORLD RADIO MAP AND STATION FINDER

The finest device of its kind published. The world's map on heavy board is divided into 22 zones, while the rotary disk shows you immediately the exact time in any foreign country. Invaluable in logging foreign stations. Also gives call letters assigned to all nations. Size 11"x22".



C—Radio Map of the World and Station Finder. 25c Prepaid

### LEAGUE LAPEL BUTTON



E—35c each

This beautiful button is made in hard enamel in four colors, red, white, blue and gold. It measures three quarters of an inch in diameter. By wearing this button, other members will recognize you and it will give you a professional air. Made in bronze, gold filled, not plated. Must be seen to be appreciated.

### LEAGUE SEALS



G—15c for 25

These seals or stickers are executed in three colors and measure 1 1/4 in. in diameter, and are gummed on one side. They are used by members to affix to station, cry, letterheads, envelopes, postal cards and the like. The seal signifies that you are a member of the SHORT WAVE LEAGUE. Sold in 25 lots or multiples only.

G—SHORT WAVE LEAGUE seals, 15c Prepaid

E—SHORT WAVE LEAGUE lapel button Prepaid 35c

EE—SHORT WAVE LEAGUE label button, like the one described above but in solid gold. Prepaid \$2.00

### SHORT WAVE LEAGUE

99-101 Hudson St., New York, N. Y.

SHORT WAVE LEAGUE 9-38 99-101 Hudson Street, New York, N. Y.

I am a member of the SHORT WAVE LEAGUE. Please send me the following short wave essentials as listed in this advertisement:

.....  
 .....  
 .....  
 .....  
 for which I enclose \$..... herewith.

Name .....  
 Address .....  
 City and State .....  
 Country .....  
 (The LEAGUE accepts money order, cash or new U. S. stamps in any denomination. Register cash and stamps.)

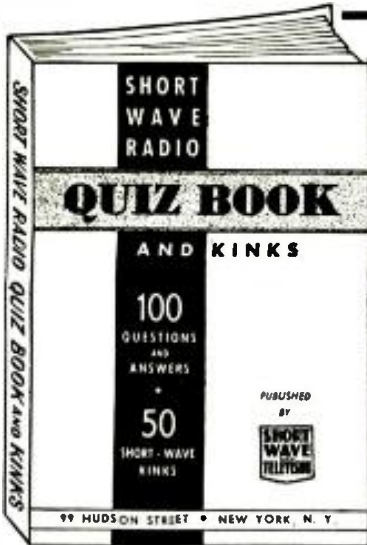

# FREE BOOKS—AND HOW YOU

CAN GET THEM!

HERE is a brand new book—with an unusually interesting content. The text—prepared by the Editorial Staff of SHORT WAVE AND TELEVISION, contains a variety of material which only experts could select and incorporate in such an excellent volume.

“SHORT WAVE RADIO QUIZ BOOK AND KINKS” cannot be bought—it is sent to you absolutely FREE with your subscription to SHORT WAVE AND TELEVISION at the Special Rate of Seven Months for One Dollar. (Old subscribers may get this book by extending their subscription.)

The book contains 64 pages with a heavy flexible colored cover. It measures 5½ x 8½ inches, and includes hundreds of photographs and diagrams. The contents are outlined below.

### Contents of the “QUIZ BOOK”

Questions and Answers Covering S-W transmitters. Questions and Answers Covering S-W Receivers. Ultra-Short-Wave Transmitters and Receivers. S-W “Kinks”—Short-cuts and Practical Wrinkles, Coil Winding Data. How to Add an Audio Amplifier to a Small S-W Receiver.

How to Connect an R.F. Stage Ahead of Your Present Receiver.

Dozens of Novel New Hook-Ups for the S-W Experimenter.

Clear diagrams showing how to connect the latest type tubes in place of your old tubes, so as to obtain greater DX.

### HOW TO “HOOK UP”—

- S-W Converters
- Noise Silencers
- Power supplies
- Modulators
- Beat Oscillators
- Antennas
- Pre-selectors
- 5-meter receivers

SHORT WAVE AND TELEVISION • 99 Hudson Street • NEW YORK, N. Y.

### 2 Other FREE Books ABC OF TELEVISION



Contains latest material on Television developments. It covers theory of scanning; simple television receiver, how the eye sees; the photo-electric cell; neon lamps; need for broad channel width in transmission of high-fidelity television signals; cathode ray tube and television receivers; Farnsworth system of television transmission, and other important features.

### SHORT WAVE GUIDE

Covers hundreds of Short-Wave questions and answers; illustrates popular Short-Wave kinks; gives instructions for building a simple Short-Wave receiver; instruction on the best type of antenna to use; diagram and construction details for building a simple “ham” transmitter; practical hints on Short-Wave tuning.



SHORT WAVE AND TELEVISION, 99 Hudson Street, New York, N. Y.

Gentlemen: Enclosed you will find my remittance of \$..... for which enter my subscription to SHORT WAVE AND TELEVISION as checked below; also send me, postpaid, the book or books which I have marked at the right.

- 7 months—\$1.00—choice of any one of three (3) books. (Canadian and foreign—\$1.30)
- 14 months—\$2.00—choice of any two (2) of the three (3) books. (Canadian and foreign—\$2.60)
- 21 months—\$3.00—all three books. (Canadian and foreign—\$3.90)
- If you are a subscriber now, we will extend your present subscription.
- New subscriber  Old subscriber

- S.W. RADIO QUIZ BOOK AND KINKS
- ABC OF TELEVISION
- SHORT WAVE GUIDE

Name..... Address.....  
City..... State.....

Send your remittances by check or money order. If you send cash or unused U.S. postage stamps, please be sure to register your letter for your own protection.

SWT-508

## The High Frequency Broadcasting Station

EVERETT L. DILLARD

(Continued from page 261)

tion, local interest, and public spirit capable of supporting a local broadcast station enterprise.

There has been the prediction of many radio engineers that eventually all of the nation's 100 watters, the so-called “local” stations will be shifted to Apex frequencies, permitted to use greater power and, as a result, actually do a better job of providing entertainment over restricted areas than they are doing at the present time. If this is ever done, six valuable radio channels will be made available for coverage of rural districts by either several high powered regional or even “cleared-channel” super-powered broadcasters. Whether or not this will ever take place is, of course, problematical—although there is every reason to believe that once Apex frequencies have been time-tested and proven, present-day local stations will be only too glad to seek refuge from increased interference by relocating in the Apex band.

High frequency broadcast stations now operate on several ultra-high frequency channels. The four lowest frequencies assigned for this purpose are: 25,950, 26,050, 26,100, 26,150 kilocycles. The next higher frequency group of channels are: 26,400, 26,450, 26,500 and 26,550 kilocycles. The majority of the Apex broadcasters now

licensed or having construction permits to build, are licensed to operate on the next higher group of frequencies, which include 31,600, 35,600, 38,600 and 41,000 kilocycles. Still another higher frequency group of four more channels is also assigned for high frequency broadcasting, namely: 40,300, 41,200, 41,600 and 41,800 kilocycles.

The first two lower frequency groups of four frequencies each are licensed for amplitude modulation only. High-fidelity aural broadcasting will be common on these channels, where a maximum allowable range of audio frequencies to be transmitted is 15,000 cps. (cycles per second). Even our so called high-fidelity stations on 1530 and 1550 kilocycles hardly claim a wider modulation frequency range than 10,000 cps. Both amplitude and frequency modulation may be used on frequencies of 31,600 kilocycles and above with 200 kilocycles as the maximum band width where frequency modulation is used.

High frequency broadcast stations are seldom licensed for an output power rating of greater than 1,000 watts, and most of these stations operate with power below this maximum value, in view of the difficulty at the present state of design of constructing and operating higher-powered transmitters at these frequencies.

These assignments as given above appear to be reasonably permanent until October 13, 1938. After that date the Commission has specifically set aside a larger number of high frequency channels. These will be licensed in two bands: a lower and a higher frequency band. The lower frequency band will extend from 25,025 to 26,975 kilocycles, with channels located 25 kilocycles from each other. This will provide 79 broadcast channels. In addition to this lower frequency band the Commission has also set aside, effective as of the same date, 75 more high frequency broadcast channels between 41,020 and 43,980 kilocycles. In this higher frequency assignment the separation of channels will be 40 kilocycles.

It is significant that on January 27, 1938, the FCC granted twenty-five ultra-high frequency channels in the new 41-44 megacycle broadcast band for the use of colleges, universities and other non-profit educational agencies. Of further significance is the fact that these licenses, which will be granted as educational high-frequency broadcast stations, will not be classed in the experimental category. Waiving the experimental clause on these stations, the Commission has this to say: “Each station shall furnish a non-profit and non-commercial broadcast service,” and



goes on further to state that these channels are not assigned on an experimental basis.

This is one of the first times that the Commission has ever assigned frequencies above 30 megacycles for other than experimental licenses. This grant, coming as it does at the crucial moment of development in ultra-high frequency broadcasting, is regarded by those of the industry as a distinct progressive step forward, for unquestionably the liberal use of these frequencies by educational institutions of America will do much to spur on public interest in reception of these frequencies. Once public interest is aroused, it remains only a matter of time for the receiving set manufacturers to produce radio sets capable of receiving these stations; and that appears to be the biggest obstacle for the moment, in the development of the ultra-highs. Starting at 41,020 kc. and ending at 41,980 kc., 25 adjacent channels, each separated by 40 kc., have been set aside and allocated for assignment to these non-commercial high frequency educational broadcast stations.

Just what the Apex broadcasters can and will do remains to be seen. Ten years from now will mean a different story in radio broadcasting as we know it today, for surely, by then, television will be an accepted commercial proposition; and television, de-

manding as it does the use of companion ultra-high frequencies adjacent to the Apex bands, will require new radio sets capable of giving good performance on the ultra-high frequencies. Is it not logical, then, that Apex broadcasters located on channels adjoining the television frequencies will enjoy and share with television the popularity of the ultra-highs? The high frequency broadcast station will provide a new type of "local" radio service that has even greater advantages than the present-day system with but very few of its disadvantages.

The amateur, the short wave listener, and the public in general can do much to aid in the development of ultra-high frequency broadcasting. Everyone who possesses a radio receiver capable of tuning to these frequency bands should make it a point to listen to these stations and channels regularly and report freely to the stations observations on reception.

Imagine, if you can, a band free from summer static and interstation interference, where even a higher fidelity of transmission is possible than that now obtained in the regular broadcast band. That should be broadcasting at its best!

The Apex frequencies promise all of these. Only time, hard work, and listeners' co-operation will tell the story.

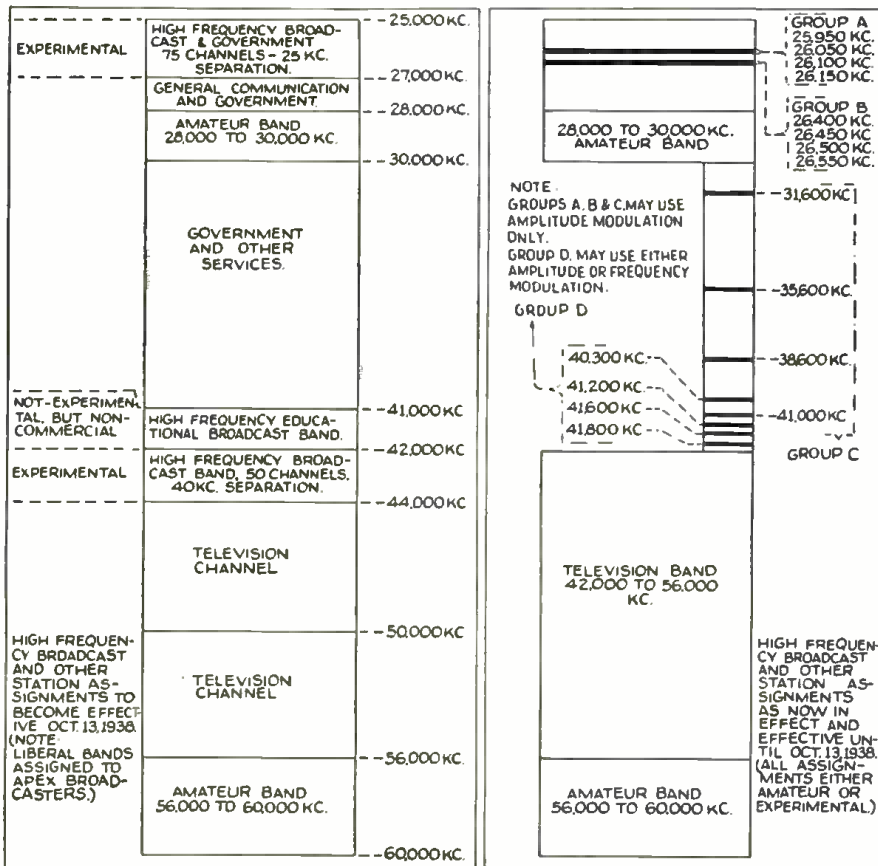

Chart showing the high frequency allocations.

"CQ"

When I was showing a local BCL my rig, and was explaining the tank coil, he asked me if it was this device that stored the energy for the rig. He also asked my aunt why I looked disgusted.—CHARLES MOURMOURIS

"CQ"

There is a girl I've heard of who became so interested in Ham radio that instead of

using mere bath salts, she would use nothing but genuine Bliley crystals in her bath water!?!X?—PAUL RUNNING.

"CQ"

On a test to find out what we knew of scientific subjects the teacher asked:

"What is a Wheatstone Bridge?"

One bright student put on his paper: "A Wheatstone Bridge is a dental filling!"

—J. S. JACKSON, JR.

**The Foursome**  
MULTIPLIES THE CONVENIENCE OF YOUR ELECTRICITY

This sturdy four-way electric outlet is manufactured by the Colt's Patent Firearms Mfg. Co. and is not to be confused with the flimsy outlets sold in chain stores.

Ideal for the radio serviceman's work bench—Test instruments, sets under test, Oscilloscopes, Speakers, Soldering Iron, etc. May be placed flat on the table or floor, also plugs directly into base outlet, as illustrated.

It may be used in homes, factories, offices and wherever several electrical devices, such as floor and table lamps, radios, toasters, percolators, irons and other electrical appliances are used.

Diameter 3 1/2", fitted with five foot flat rubber cable and plug. Weight 1 lb. (Factory List Price \$2.50) Our special Price

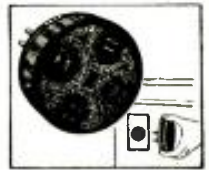

F.O.B. N. Y.  
3 for \$1.50 **75c**

An Accurate, Eight Inch White Wood

### SLIDE RULE

With A, B, C, D, C1 and K Scales

#### Features

Nickel Silver Framed Indicator with integral friction springs. Scales calibrated directly on well-seasoned wood will retain accuracy regardless of temperature or humidity changes. Instructions and illustrations of primary operations clearly printed on back side of rule for ready reference or teaching. Each rule in a durable pocket carrying case for convenience and protection.



The extremely low price of these slide rules and their absolute accuracy makes them ideal for the student as well as the working man who has always wanted to learn to use a slide rule.

Price **25c** plus 5c postage.

20 Page Book of Instructions for using a slide rule. 5c each, plus postage

36 page Book of 300 Examples and Answers. 10c each, plus postage.

### STURDY BINDERS

for any size magazines. Covered with black corrugated fabricoid. Has two stamped metal ends with 12 Spring Wire separators. Magazine can be inserted and removed in a jiffy.

12 1/2" x 9 3/4" fits S.W.&T. Radio News, etc. . . . . 80c  
10 3/4" x 7" fits Popular Mechanics, etc. . . . . 70c  
8 3/4" x 5 3/4" fits Readers Digest, etc. . . . . 60c

### STOPPANI COMPASS

A Precision Instrument made in Belgium. Purchased by the U. S. Government at more than \$30.00 each. Ideal for Radio Experimenters Laboratory, also may be used as a Galvanometer for detecting electric currents in radio circuits. Ruby jeweled, solid bronze, 4 inches square, fitted in a hardwood case.

Also used by hunters and surveyors.

Our price prepaid \$4.50 each

Send 10c for catalog, which includes a Facsimile of the Declaration of Independence, 9" x 10", with buff background, suitable for framing. Regular Price of Facsimile alone 15c.

### GOLD SHIELD PRODUCTS

Dept. 89 350 Greenwich St. New York

# THESE OUTSTANDING SHORT WAVE BOOKS ARE Now Available AT YOUR DEALER!

YOU buy parts, tubes, kits, accessories from your local radio dealer—that's what countless thousands of short-wave fans do. Now through a nation-wide distribution service our numerous books are available at your favorite radio dealer—right where you buy other radio equipment. It's more convenient, saves time and you can inspect the books before you buy. Ask your dealer to show you all the books advertised on this page—they're always in stock.

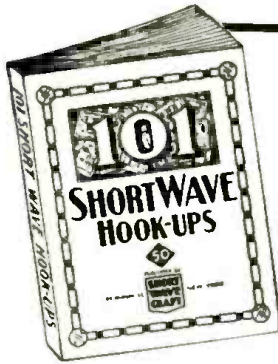

**101 SHORT WAVE HOOK-UPS**  
 Compiled by the Editors of **SHORT WAVE and TELEVISION**  
 Here is a worthwhile book that every short wave listener, every short wave fan, and every short wave amateur has wanted for a long time. It gives you the 101 best short wave hook-ups which have appeared heretofore.  
 100 Illustrations  
 72 Pages **50c**

**HOW TO BUILD AND OPERATE SHORT WAVE RECEIVERS**  
 This is the best and most up-to-date book on the subject. It is edited and prepared by the editors of **SHORT WAVE and TELEVISION** and contains a wealth of material on the building and operation, not only of typical short wave receivers, but short wave converters as well.  
 150 Illustrations  
 72 Pages **50c**



**HOW TO GET BEST SHORT WAVE RECEPTION**  
 M. HARVEY GERNSBACK tells you everything you have ever wanted to know about short wave reception. The author, a professional radio listener and radio fan for many years, gives you his long experience in radio reception and all that goes with it.  
 40 Illustrations  
 72 Pages **50c**

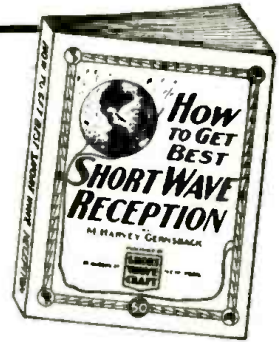

**HOW TO BECOME AN AMATEUR RADIO OPERATOR**  
 By Lieut. Myron F. Eddy, whose experience in the amateur field has made him pre-eminent in this line.  
 If you intend to become a licensed code operator, if you wish to take up phone work eventually—this is the book you must get.  
 150 Illustrations  
 72 Pages **50c**

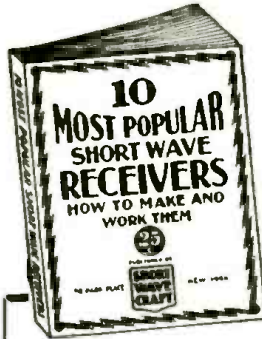

**TEN MOST POPULAR SHORT WAVE RECEIVERS**  
 HOW TO MAKE AND WORK THEM  
 The editors of **SHORT WAVE and TELEVISION** have selected ten outstanding short wave receivers and these are described in the new volume. Each receiver is fully illustrated with a complete layout, pictorial representation, photographs of the set complete, hook-up and all worthwhile specifications.  
 75 Illustrations  
 40 Pages **25c**

**THE SHORT WAVE BEGINNER'S BOOK**  
 Here is a book that solves your short wave problems—leading you in easy stages from the simplest fundamentals to the present state of the art as it is known today. It is the only low-priced reference book on short waves for the beginner.  
 75 Illustrations  
 40 Pages **25c**

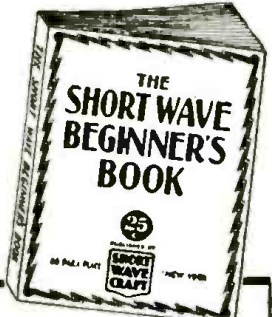

## LOOK FOR YOUR NEAREST DEALER

For convenience the publishers list below dealers in all parts of the world where our books are available. On your next shopping trip be certain to examine these volumes. You're sure to want them for your technical library.

- ALABAMA**  
Waltner Bros., Montgomery
- ARIZONA**  
Sam's Cigar Store, Phoenix
- CALIFORNIA**  
Electric Supply Co., Oakland  
Radio Supply Company, Los Angeles  
Radio Television Supply Co., Los Angeles  
Pacific Radio Exchange, Inc., Los Angeles  
Western Auto Supply, Los Angeles  
Zack Radio Supply Co., Los Angeles  
Vroman's Book Store, Pasadena  
Western Radio & Elec. Co., San Diego  
Offenbach Electric Co., San Francisco  
Technical Book Co., San Francisco  
Zack Radio Supply Co., San Francisco  
Radio Specialties Co., San Jose
- COLORADO**  
Auto Equipment Co., Denver  
Interstate Radio Supply, Denver
- CONNECTICUT**  
The Edward P. Judd Co., New Haven
- DELAWARE**  
Wilmington Elec. Spec. Co., Inc., Wilmington
- FLORIDA**  
Radio Accessories Co., Orlando
- GEORGIA**  
Wholesale Radio Service Co., Inc., Atlanta
- ILLINOIS**  
Allied Radio Corporation, Chicago  
Walter C. Braun, Inc., Chicago  
Chicago Radio Apparatus Co., Chicago  
A. C. McClary & Co., Chicago  
Midwest Radio Mart, Chicago  
Newark Electric Co., Chicago  
Sears, Roebuck & Co., Chicago  
Max Stein & Co., Chicago  
Montgomery Ward & Co., Chicago  
Wholesale Radio Service Co., Inc., Chicago

- INDIANA**  
Van Sickle Radio, Indianapolis
- MASSACHUSETTS**  
Dewolfe & Fiske Co., Boston  
The Personal Book Shop, Boston  
Wholesale Radio Service Co., Inc., Boston
- MISSOURI**  
Library Book House, Springfield  
Trenout Elec. Supply Co., Boston
- MICHIGAN**  
Rissi Brothers, Detroit
- MINNESOTA**  
St. Paul Book & Nat. Co., St. Paul
- MISSOURI**  
Burstein-Appelberg Co., Kansas City  
Radio Labs., Kansas City  
Walter Asme Radio Co., St. Louis  
Van Sickle Radio Co., St. Louis
- NEW JERSEY**  
Radio Apparatus Co., Newark  
United Radio Co., Newark  
Wholesale Radio Service Co., Inc., Newark
- NEW YORK**  
Fort Orange Radio Dist. Co., Albany  
Wholesale Radio Service Co., Inc., Bronx  
Wholesale Radio Service Co., Inc., New York City  
American News Co., New York City  
Baser & Taylor Co., New York City  
Hau, the Radio Man, New York City  
David Hogen & Co., New York City  
Federated Purchaser, Inc., New York City  
Harrison Radio Co., New York City  
Radio Circular Co., New York City  
G. E. Steinhilber & Co., New York City  
The Steiner Co., New York City  
Sun Radio Co., New York City  
Thor Radio Corp., New York City  
Try-We Radio Co., New York City  
Van Henssedyck Book Stores, New York City  
Wholesale Radio Service Co., Inc., New York City  
H. W. Wilson Co., New York City  
Radio Parts & Equipment Co., Rochester  
M. Schwartz & Son, Schenectady

- OHIO**  
College Book Exchange, Toledo
- OREGON**  
J. K. Gill Co., Portland
- PENNSYLVANIA**  
Radio Electric Service Co., Philadelphia  
Canteradio Co., Pittsburgh
- WASHINGTON**  
Seattle Radio Supply Co., Seattle  
Wedel Co., Inc., Seattle  
Spokane Radio Co., Spokane
- WISCONSIN**  
Radio Parts Co., Milwaukee
- ARGENTINA**  
Radio Revista, Buenos Aires
- AUSTRALIA**  
McGill's Authorized Agency, Melbourne
- BELGIUM**  
Ennil Arens, Brussels
- CANADA**  
T. Eaton & Co., Winnipeg, Man.  
Electrical Supplies, Ltd., Winnipeg, Man.  
Wholesale Radio Supply, Winnipeg, Man.  
Canadian Electrical Supply Co., Ltd., Toronto, Ont.  
Radio Trade Supply Co., Ltd., Toronto, Ont.  
Canadian Electrical Supply Co., Ltd., Montreal, P. Q.
- BRAZIL**  
Arenca Soave, San Paulo
- CHINA**  
China News Co., Shanghai  
International Bookellers, Ltd., Shanghai
- CUBA**  
Diamond News Co., Havana
- ENGLAND**  
Garringer's Amer. News Agency, London
- FRANCE**  
Toute La Radio, Paris
- GERMANY**  
Rehr G.M.B.H. SW15, Berlin NW No. 7

**HOLLAND**  
Radio Peeters, Amsterdam, Z.

**INDIA**  
Empire Book Mart, Bombay

**MEXICO**  
American Book Store, Mexico, D. F.  
Central De Publicaciones, S. A., Mexico, D. F.  
Jaques Salvo, Mexico, D. F.

**NEW ZEALAND**  
Johns, Ltd., Auckland  
James Johnston, Ltd., Dunedin  
Te Aro Book Depot, Ltd., Wellington

**SOUTH AFRICA**  
Technical Book Co., Cape Town  
Central News Agency, Johannesburg  
International House, Johannesburg  
South African Radio Publications, Johannesburg

**IF YOUR DEALER DOES NOT CARRY THESE BOOKS, ORDER DIRECT FROM US. FILL OUT COUPON BELOW. SHIPMENT WILL BE MADE IMMEDIATELY.**

**POPULAR BOOK CORPORATION SW-9**  
99 Hudson Street, New York City.

Gentlemen: I enclose herewith my remittance for \_\_\_\_\_ for which please send me the following books:

Name \_\_\_\_\_

Address \_\_\_\_\_

City \_\_\_\_\_ State \_\_\_\_\_

(Send remittance in form of check or money order. If letter contains cash or unused U. S. postage stamps, recheck it.)

POPULAR BOOK CORPORATION • Publishers • 99 HUDSON STREET • NEW YORK, N. Y.



## Third Silver Trophy Award

(Continued from page 279)

The final is an Amprex HF-200 single-ended stage.

A Hallicrafter SX17 Super Skyrider is used for receiving, and this set has assisted me greatly in "working" nearly 30 countries.

A doublet  $\frac{3}{4}$  wave— $\frac{1}{4}$  wave antenna is used for receiving and transmitting and is connected by means of a low-loss, double-pole double-throw relay, actuated by the start control on the transmitter.

### Rules for Trophy Contestants

● WOULD you like to win one of these beautiful silver trophies? It is very easy to do so—simply send the Editors, a good, clear photograph of your Ham station. If your station photo is selected as the best of those submitted each month, you will be awarded one of these handsome silver trophies with your name engraved on it.

The trophy stands nearly 12" high and is a fine example of the silversmith's art. We are sure that every Ham in the country will be tickled with it, if he should win it. The silver trophy represents the spirit of victory and it was designed by one of the leading silversmiths. The name of the winner each month will be engraved on a silver plate mounted on the black bakelite pedestal before the trophy is sent to the successful contestant.

The winner of the fourth trophy award will be announced in the Oct. issue, and the closing date for that contest is Aug. 10.

The judges of the contest will be the Editors of SHORT WAVE & TELEVISION. In the event of a tie, duplicate prizes shall be awarded to the contestants so tying.

### Note These Important Rules

The photos must be sharp and clear and preferably not less than 5" x 7".

The pictures will be judged for the general layout of the station, the quality of workmanship exhibited, and the appearance of the photograph itself. The judges will also consider neatness as an important point.

When you submit the photograph of your Ham station, send along a brief description not longer than 300 words, describing the general line-up of the apparatus employed, the size, type and number of tubes, the type of circuit used, name of commercial transmitter—if not home-made, watts rating of the station, whether for c.w. or phone or both, etc., also name of receiver.

State briefly the number of continents worked, the total number of stations logged or contacted, and any other features regarding the station which you think will be of general interest to the reader. Mention the type of aerial system used, especially any unique or new features about it, and which type of aerial you use for transmitting and receiving; also what type of break-in relay system, if any, is used.

Important—Don't forget to send along a good photograph of yourself, if your likeness does not already appear in the picture!

Note that you do not have to be a reader of SHORT WAVE & TELEVISION in order to enter the contest. Pack all photographs carefully and the description had best be mailed in the same package with the photos. The Editors will not be responsible for photos lost in transit.

Do not send small, foggy-looking photos because they cannot be reproduced properly



# HEY FELLOWS! 6 BACK NUMBERS OF SHORT WAVE AND TELEVISION SENT ANYWHERE IN U.S. FOR 70¢

For a limited time only, and as long as they last, we will send you six back numbers of SHORT WAVE & TELEVISION assorted, your choice, for 70 cents.

The usual price for six copies would be \$1.50, and most publishers charge a higher price for back numbers over one year old.

We can supply only the following back numbers: Dec., 1930; Feb., April, June, Sept., Oct., 1931; July, Aug., Oct., 1932; Jan., April, Oct., Nov., Dec., 1933; Jan., Feb., Mar., April, May, Aug., Sept., 1934; 1935—All issues except January, February and March; 1936—All issues; 1937—All issues; 1938—All issues to date.

If you do not specify copies, we will send assorted numbers to fill your order. Note, we cannot exchange the copies for ones that have been sent to you.

Every copy of SHORT WAVE & TELEVISION

contains information which you should have. Here is a chance to get those copies.

As only a small supply of back numbers on hand, this offer will be withdrawn as soon as they have been sold.

We accept U. S. stamps, U. S. coin, or money order. Rush your order today.

SHORT WAVE & TELEVISION 9-38  
99-101 Hudson Street, New York, N. Y.

Gentlemen: I enclose herewith 70c, for which you are to send me six back number copies of SHORT

WAVE & TELEVISION as follows:.....

Name .....

Address .....

City ..... State .....

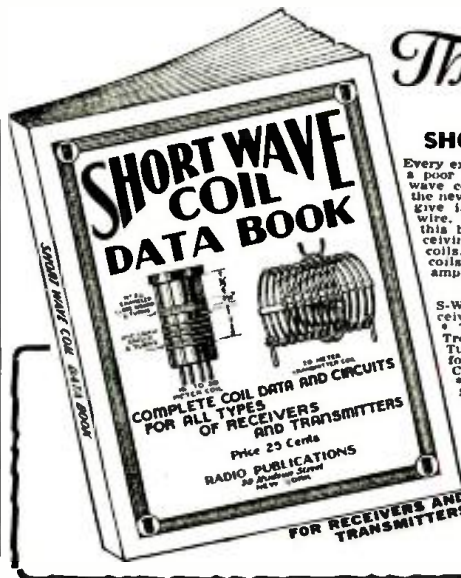

# The 1 and ONLY

## SHORT WAVE COIL DATA BOOK

Every experimenter knows that the difference between a good and a poor radio set is usually found in the construction of short-wave coils. Coil winding information is vitally important and in the new coil book all "dope" appears. There's illustrations which give instructions on how to wind coils, dimensions, sizes of wire, curves and how to plot them. Every experimenter needs this book—it also contains complete data on all types of receiving coils, together with many suitable circuits using these coils. Also complete data on various types of transmitting coils with many transmitting circuits such as exciters and amplifiers using the various coils described.

### Contents Briefly Outlined

S-W Tuning Inductance Charts • Coil Data for T. R. F. Receivers • One Tube Oscillodyne • Two Tube Bandspreader • The Mono-Coil • 2-Tube Old Reliable • 2-Tube Globe Trotter • 2 Winding Coils—10-500 • Meters • Double 3-Tube "Signal Gripper" • Electrified • 3-Tube Bandspreader for the Ham • General Coverage Coils on Ribbed Forms • Coil Data for Superhet or S-W Converter • Ultra S-W Coils • Switch Coils for S-W Superhets • Experimental Coils • S-W Antenna Tuner • Most Popular S-W Tuning Circuits • Self-Supporting Transmitting Circuits Employing Coils Described • All Band Antenna Tuner for Transmitting • Plug-in Coils for Exciters • Frequency-Wavelength Conversion Chart.

PRICE 25c PREPAID

For a copy of this handy book, send

25c in U.S. Coin or stamps to

**RADIO PUBLICATIONS**

97 HUDSON STREET NEW YORK, N. Y.

in the magazine. If the picture you have or may take of your station is not thoroughly sharp and clear and at least 5" x 7", it would be best to have a commercial photographer take a picture of your station. If you cannot do this, you most probably have a friend who owns a good camera and who can arrange to take the photograph. You are not limited to one picture, but may submit as many different views as you like.

Address all photos and station descriptions to Editor, Ham Station Trophy Contest, c/o SHORT WAVE & TELEVISION, 99 Hudson Street, New York, N. Y.

Plenty of Construction Articles in  
**That OCTOBER NUMBER!**

Don't miss it!!

Every "Ham" and "Fan" will read it—  
cover to cover!!

## Formulas and Recipes FOR THE PRACTICAL MAN

### CONTENTS OF BOOK

1. Adhesives; Glues, Cements, Gums, Mucilages, Lubricants. 2. Cleansing: Stain Removers, Paint Removers, Bleaches, Cleaning Fluids. 3. Metal Craft: Coloring, Oxidizing, Plating, Repairing, Welding, Polishes, Alloys, Solders, Amalgams. 4. Paints: Colors, Stains, Varnishes, Enamels, Luminous Paint, Washable Paint; Paint-Removing, Waterproofing, Fireproofing. 5. Glass-Working: Cutting, Drilling, Boring, Bending, Blowing, Etching, Engraving, Frosting, Silvering, etc. 6. Wood-craft: Fillers, Fireproofing, Acid-proofing, Waterproofing; Furniture Polishes, Finishes, etc. 7. Inks: Recipes, Eradicators, Ink Stain Removers; Special Inks; Colored, Indelible Sympathetic, Invisible, Hectograph. 8. Photography: Developers, Emulsions, Fixers, Sensitizing, Toning, Printing, Photographic Paper, Blueprint Paper. 9. Antidotes for Poisons, Remedies for Burns and Scalds, Disinfectants, First-Aid in Accidents, Emergency Remedies, Home Remedies. 10. Preparation, Manipulation, Handling, Mixing, Measuring, Weighing, Filtering, Straining Solutions; List of Technical Substances; Emulsifying; Use of Hydrometer; Use of Thermometer; Tables of Weights and Measures, Decimal System, Useful Tables.

PRICE 50c Postpaid

Send stamps, cash, check or Money Order

**TECHNIFAX**

Division SWT-938

558 W. WASHINGTON BLVD. CHICAGO, ILL.



# COMMERCIAL NOTICES 10¢ A WORD

Under this heading only advertisements of a commercial nature are accepted. Remittance of 10¢ per word should accompany all orders. Copy should reach us not later than the 10th of the month for the second following month's issue.

## ADVERTISING AGENCIES

**ADVERTISE:** 24 WORDS IN 250 newspapers \$10. Lists free. Advertising Service Bureau, 4515-S Cottage Grove, Chicago.

## AGENTS WANTED

**300% PROFIT SELLING GOLD Leaf letters for Store Windows:** Free samples. Metallic Co., 416 North Clark Chicago.

## BUSINESS OPPORTUNITIES

**"PROFITS"—STAMPING IDENTIFICATION keychecks, outfits furnished.** Name, address on sample 2c. Holm Co., Box 17, 86, Wilkes-Barre, Penna.

## CORRESPONDENCE COURSES

**500,000 USED CORRESPONDENCE Courses and Educational Books.** Sold, Rented, Exchanged. Kit (buys); key Satisfaction guaranteed. Cash paid for used courses. Complete details and bargain catalog free. Send name. Nelson Company, 3282 Manhattan Building, Chicago.

## INSTRUCTION

**RADIO ENGINEERING, BROADCASTING, aviation and police radio, servicing, marine and Morse telegraphy taught thoroughly.** All expenses low. Catalog free. Dodge's Institute, Col. St., Valparaiso, Ind.

**MAKE YOUR OWN ELECTRIC fuse plugs.** Model and instructions \$1.00. W. Stonebraker, 6006 Harney, St. Louis, Mo.

## MISCELLANEOUS

**LEARN TO WRITE FREE COURSE sent with Complete Kit (buys); key resembling standard type) and manual with experimental diagrams, valuable formulae, data. 25c coin. WSPWR, 13501 Chermere Ave., Cleveland, Ohio.**

**TOOLS, DIES, AND SOME FINISHED stock for manufacturing a household product that any man with some executive ability can with proven results have success.** Stamp Please, Irvin DeJoy, Muncie, Indiana.

**OPERATE PROFITABLE CLIPPING bureau.** Starting copy—25c. Bohm Co., Box 86 A.A., Wilkes-Barre, Pa.

**HAVE AUTOMATIC VIBRO razor new, American Flyer typewriter new, the Rocket Stencil letter duplicator new, Stephenson Laboratory foot correction course and featherweight arch making, with working material.** cost \$150.00. Dr. Earl Ward Pierce, Eye training course, in 15 lessons.

cost \$20.00. 96 violin lessons from the U. S. School of Music, all in good shape. Want small electric motor, electric table lamp, radio, kitchen heater, mantle clock or cash. F. Miller, 459 S. Joliet St., Joliet, Ill.

**3 1/2 INCH TR. 0-125 VT. A.C. Voltmeter, 0-10 A.C. Ammeter, \$2.75 each. Weston D.C. 0-7 and 0-140 Voltmeter, 2 1/2" with 9 pt. D.P. Switch \$2.75. Nat'l. MB27-4. Sig. T.R.F. chassis and Thord. 45 P.P. Pack \$7.50. 10" MUTER DYN. SPKR. \$3.00 Victor 7 1/2" Hi-Fi Orthophonic Horn, Mag. and Acoustic Pick-ups, \$10.00, plus express. \$400.00 RCA battery Superhet—\$25.00. Harry Ackerson, Hamsy, N. J.**

**WE OFFER SUBJECT TO PRIOR sale 7 m.in. lacquered cable used by the Government. It is an ideal cable for high voltage, low current service, such as used in radio transmitters, amplifiers, etc. It is a special steel wire, 20 gauge, with very heavy rubber insulation. Worth 12c a foot. Special price 50 ft. \$2.00, 100 ft. \$3.00. F.O.B., N. Y. Gold Shield Products, 350 Greenwich St. New York City.**

## MODELS

**\$9.85 FOR A COMPLETE METAL working lathe.** Other new and used work shop equipment. Stamp please. DeJoy Model Shop, Muncie, Indiana.

## OFFERED FOR SALE

**TODAY'S BIGGEST VALUE.** Beautiful hand finished wood birthday folders assorted shapes and colors, 25c each, 5 for one dollar. Star Cards, % of Stachteger, Rts. 1, Box 99, Chowchilla, California.

**STEER HORNS FOR SALE.** SIX to eight feet spread. Polished and mounted. Free photo. Lee Bertillon, Mineola, Texas.

**FOR SALE—BRAND NEW P.A. rician Model Man's Waterman fountain pen.** Cost \$10; will sell for \$5. Albert A. Banick 3742 77th Street, Jackson Heights, N. Y.

## PATENT ATTORNEYS

**INVENTORS—PROTECT YOUR rights before disclosing your invention to anyone.** Form "Evidence of Conception"; "Schedule of Government and Attorneys' Fees" and instructions sent free. Lancaster, Allwine & Roumel, 436 Bowen Building, Washington, D. C.

## PETS

**BULMSTIFF PUPPIES—REAL Guards.** Useful, intelligent companions \$10.00 and \$12.00. Paul Muenchow, Merrill, Wisconsin.

## QSL CARDS—SWL

**100 NEAT SWL CARDS PRINTED with your name and address sent post-paid for \$1.** bunch of samples and RST Chart for five cents in stamps. WIBEF, 16 Stockbridge Ave., Lowell, Mass.

**QSL CARDS, 300 FOR \$1.00.** Quality printing. Free samples. Miller Printing Co., 399 Thirteenth Ave., Columbus, Ohio.

## RADIO

**ONE TUBE BATTERY LAUD- speaker radio.** Simple, inexpensive. Wiring diagram, parts list 50c. Maurice Fowler, Blairsburg, Iowa.

## SHORT WAVE RECEIVERS

**COMMUNICATION RECEIVER—4 to 550 meters,** at the phenomenally low price of \$10.85. (Regular amateur net price \$15.85.) Complete with 4 tubes, loudspeaker and built in A.C. high voltage power supply. A very unusual opportunity. Due to over-production of our popular AC-4 model, regenerative—super-regenerative receiver, we are disposing of a limited number at this unheard-of price. Smooth, sensitive super-regenerative circuit over the rest of its tremendous tuning range with no skips. Act now! First come, first served. Fully guaranteed for 1 year. Radio Constructors Laboratories, 136 Liberty St., New York, N. Y.

**USED DORRLE'S, D-38, BS-5, 7C,** reconditioned by factory, 40% off. See January Short Wave & Television for description. Kusterman, 68 Barclay St., New York.

## TELEVISION

**TELEVISION EQUIPMENT SINCE 1927.** Arthur Pohl, 2123 Hubbard, Detroit, Mich.

## TOOLS

**USED POWER TOOLS, WORK- shop equipment—direct owner prices.** Buy or sell through our service. Latest lists, 20c. Toolisting, Box 481-T, Zanesville, Ohio.

## WANTED TO BUY

**POWER TOOLS, WORKSHOP equipment wanted.** Hundreds cash buyers, your own prices. Toolisting, Box 581-T, Zanesville, Ohio.

# FOR SALE (NON COMMERCIAL) 3¢ A WORD

Under this heading we accept advertisements only when goods are offered for sale without profit. Remittance of 3¢ per word should accompany all orders. Copy should reach us not later than the 10th of the month for the second following month's issue.

**SELL HALLICRAFTERS SKY Chief \$28, original price \$45.** Excellent condition. Mechanical handspread. Covers amateur bands 20 to 160 meters, foreign, police, etc., and broadcast. Dimity Holiday, 42 Irton Street, Waterbury, Connecticut.

**10 TUBE SUPERHETERODYNE 15-550 meters, 4 tube Audio Amplifier 10" speaker, metal tubes, crystal con-**

**trol, noise silencer circuit, Tube tuner, Aladdin Polytron coils, price \$50. H. Nielsen, 350 7th St., Brooklyn, N. Y.**

**FOR SALE: ULTRA SPFRATORS—phere Trans-Receiver 10 tubes short wave sending and receiving with mike and key jack, has tuning eye 2 1/2 to 4000 meters, used about 3 months, gets European stations on loud speaker and all amateur bands. Have coils 2 1/2**

**to 550 meters bands only. Sale price \$25.00. Carl Jensen, 211 East 200 St., Bronx, N. Y.**

**OFFICIAL DORRLE AC-5, EX- cellent condition. \$15. Write Howard Davis, Box 260, Thornwood, N. Y.**

**SW3 \$9.00, SKY BUDDY \$19.00, PR-10 \$29.00. W9ABA, Butler, Mis- souri.**

# 3¢ A WORD CHANGE—FREE!

NO ADVERTISEMENT TO EXCEED 35 WORDS, INCLUDING NAME AND ADDRESS

Space in this department is not sold. It is intended solely for the benefit of our readers who wish to buy or exchange radios, parts, phonographs, cameras, bicycles, sporting goods, books, magazines, etc. As we receive no money for these announcements, we cannot accept responsibility for any statements made by the readers. Use these columns freely. Only one advertisement can be used. Copy should reach us not later than the 10th of the month for the second following month's issue.

accepted from any reader in any issue. All dealings MUST be above board. Remember you are using the U. S. mail in all these transactions and therefore you are bound by the U. S. Postal Laws. Describe anything you offer accurately and without exaggeration. Treat your fellow men the way you wish to be treated. We welcome suggestions that will help to make this department interesting and profitable to our readers.

**WILL TRADE LIONEL ELECTRIC train, midjet box camera, invisible ink powder or formula, instructions how to restiver mirrors, how to etch on glass, also how to make artificial marble.** Hill Schroeder, 803 Wisconsin, Peoria, Illinois.

**HAVE: WURLITZER GUITAR, boy's cloth bound books, want N.W. radio or kit. Must be A.C. or what have you? Swap lists. Joseph Kubik, 37 Pine St., Ct. Barrington, Mass.**

**WILL TRADE "RADIO SERVICE Business Methods" by Rider (unread; List \$3.00) for a 6L6. Also stamp collection, 500 stamps for a 40 or 80 meter crystal. Jim O'Rourke, 2019 So. Nicollet, Sioux City, Ia.**

**WILL SELL OR TRADE COM- memorative coins for other coins. What have you? R. H. Manstets, Farmer Cafe, Lynchburg, Va.**

**HAVE POPULAR AND CLASSIC cat piano books and pieces, 23 Popular Mechanics, "BB" gun, microscope, Dto game, radio parts, ukelele, for photo enlarger, photographic equipment, or what have you? Henry Zimmerman, 4316 W. Kamerling Ave., Chicago, Illinois.**

**HAVE 7 ISSUES RADIO NEWS (July 1937—Jan. 1938) Taylor tube manual, 3 1/2 lessons Radio and Prie- tion, Italy Brown camera. Would like good microscope or what have you? Sylvester Panagapko, Renwer, Manitowish, Wis.**

**TRADE 15 TUBE RCA 5 BAND console radio model K-15, RCA 143 table model 3 hand receiver perfect condition for commercial type com- munications receiver, transmitting equipment or? M. W. Shellhammer, 258 Browe St., Tamaqua, Penna.**

**WILL SWAP NEW UNUSUAL different match covers for unused stamps any kind. I'll send covers you return stamps as you feel a fair swap. Satterthwaite, 544 Colonial Ct., Toledo, Ohio.**

**ONCELOSCOPE, MODEL 65, SIG- nal generator, Bendix Dayrad, practically new. Trade for good camera with fast lens or what have you. E. M. JOHNSON, 711 S. Dundee St., South Bend, Ind.**

**WANTED SHORT WAVE SET.** Have old magazines, camera lens, etc. Robert Pinnix, R.F.D. No. 1, Box 357, Winston-Salem, N. C.

**HAVE MODEL A ARGUS CAMDID camera also case. Would like 4 or 5 tube A.C. D.C. short wave receiver. F. Sanchez, C.V. F137 Co. 1249, Coeur d'Alene, Idaho. (Continued on page 317)**

# Talking on 1-Meter Waves

(Continued from page 267)

also be applied to the sending aerial. In order to determine this increase when working with a Yagi receiving aerial, a thermocouple is placed in the dipole on the receiving side. By successively inserting and removing rods, which give the aerial its directive qualities, the above mentioned factor can be easily measured. The transmitter can be gauged in a similar manner. By measuring the field at a great distance, one also finds that the rate of amplification runs as high as 3.5.

Next the variation of field intensity with the distance is measured. The sensitivity of the receiver should be calibrated by means of a signal of known intensity; for this purpose a generator is employed with an antenna of which the radiating part is short compared with the wavelength, while a horizontal plate acting as a condenser at the foot of the dipole produces a uniform distribution of current in the vertical part. The current in this vertical element can be determined from the capacity and the potential of the condenser, measured with a voltmeter containing a very small tube (diode).

In experiments which deal with ultra-short waves, the inductance and the capacity of the wires which connect the transmitter with the aerial play an important role. From the very first experiments coaxial feeders were used. In such wires, which are about 20 meters (64 ft.) long, the loss is 50% at the most. But hoar frost and snow interrupt transmission completely, and in damp weather the losses are also high. Therefore, the feeder has been protected against wet weather, and the dipole has been placed in a glass tube, while all the apparatus are kept inside at a proper temperature. By this method the difficulties seem to have been overcome.

In the transmitter, triode tubes are used. They are constructed in such a manner that they normally are able to generate waves of about one meter. Our picture shows one of these tubes, in which the outlets of grid and plate are placed in the upper part and are supported and isolated by glass columns. The filament is mounted in the usual manner. The dimensions are such that the damping due to the time the current requires in passing through, is not prohibitive even at very high frequencies.

In order to obtain a transmitter which can be regulated easily, a symmetrical installation is employed, with proper heating current conductors. This enables the transmitter to work at various wavelengths in a simple manner, with the best possible results.

The modulation is effected by variation of the plate voltage. The modulator is equipped with a balanced amplifier and has six tubes. By this type of modulation the frequency is subject to variations. In order to keep these variations sufficiently small, an LC circuit with small losses is used. This circuit replaces the more expensive and less robust crystal which is used in stabilizing the frequency of longer waves.

For the reception of ultra-short waves there are several possibilities. One may use super-regeneration, super-heterodyne and super-autodyne (super self-heterodyne) receivers. It is desirable that the power be supplied from alternating current lines, and it is also advisable to use modern ultra-short wave apparatus of the low-loss type. Everything considered, the choice goes to super-autodyne receivers.

As mixing tubes very small triodes are used, in which the time the electrons require



for passage is rather short. These tubes also have a lower capacity than ordinary tubes. They can, therefore, produce waves much shorter than are used in our case.

The receiving aerial is like the sending aerial—a Yagi type, and it is connected by means of a coaxial feeder with the receiver. The picture of the oscillator-modulator shows the two wires wound as a spiral (Lecher system). In the upper part one can see the bridge which makes it possible to tune the frequency of the Lecher system to the frequency which is received.

The receiver may be tuned by employing the following means:

(1) Modifying the length of the Lecher system by means of the bridge;

(2) Displacing the connecting point of the coaxial feeder which comes from the aerial;

(3) Varying the coupling between the coils.

The intermediate frequency amplifier, because of the great width of its frequency band, is quite different from an I.F. amplifier employed for broadcast reception. Neither the frequency of the transmitter or of the receiver oscillator is absolutely stable. It is necessary to employ for the intermediate frequency amplifier a bandwidth of 400 kc. with an I.F. of about 7500 kc. This can be done without great difficulty. If desired, the usual automatic volume control can be added.

The intensity of the carrier wave which is used in the transmission from Tilburg to Eindhoven is recorded in the following manner:

The continuous current which is furnished by the detector of the receiver passes through, besides the coupling resistance on the way to the output tube, a second resistance. After amplification by means of a D.C. amplifier (two pentodes in push-pull) the drop in voltage in the last resistance furnishes enough energy to feed a calibrated milliammeter.

It has been established that it is possible to install, without further precaution, receiver and transmitter side by side; the interference is negligible.

## Radio Pilots Ships into Port

(Continued from page 268)

radio telephone to tugs, fishing trawlers, oil tanks and other inshore vessels.

And now the pilots can pick up the phone and tell the operator ashore to connect them with any number of their choosing. In New York City, Captain James E. McCarthy, supervisor of the pilot boats and himself a veteran of more than 40 years in the pilot service, picks up the office phone that he uses in his other daily routine—and calls one of his pilot boats. Likewise, other vessels in the vicinity of New York which are thus equipped may talk with any desired points in the Bell System or with each other through the medium of the marine radio telephone station on Staten Island. And when they proceed to other vicinities, there are other shore stations to handle their calls and link them with the Bell System, for marine radio telephone stations are also in operation at Boston, Miami, Los Angeles, San Francisco and Seattle, and another is under construction at Norfolk.

Pilot boats transmit to shore stations on 2198 kc. (136 meters); receive from shore stations on 2590 kc. (115.8 m.); and work intership direct on 2739 kc. (109 m.).

# BARTER and EXCHANGE FREE ADS (continued)

**SWL'S AND HAMS—I WOULD** like to exchange U.S.A. and foreign correspondence. Will answer immediately. QRA John Jenkins, Jr., 423 Hill Ave., Glen Ellyn, Ill., U.S.A.

**WANTED USED UNIVERSAL** (Tipper, Natl. SW3 with coils, etc. Have four tube battery radio with speaker, also 180 volt power packs. Swap for what have you? Richard Daly, 2098 Carroll Ave., St. Paul, Minn.

**WANT—1 SHORT WAVE RECEIVER.** Will swap Argus camera and case, also complete drafting set and 5 photography magazines of recent issue and printing frame. Seymour Albin, 255 Quincy Ave., New York, N. Y.

**SWAP, PHILCO OMC MODEL 98B**, Supreme model 333. Want Oac and oscillograph and Riders six, seven and eight, or will buy the above, write Corneille WBAJ, 116 East Platt, Maquoketa, Iowa.

**HAVE A GOOD MECHANICAL MICROSCOPE.** Worth \$100. 12000V—25 Ma. transformer. 6V Dynamotor. Want good phone xmitter and s.w. receiver, testing equipment or what have you? E. Rusconi, 6942 Ave. K., Houston, Tex.

**I HAVE CRYSTALS, POWER SUPPLIES, 5 meter equip., transmitters 40, 80, 160. Need tube tester and test equip. anything? What do you have? M. S. Muse, 805 N. Mizey, Sherman, Texas.**

**TRADE FOR SERVICE INSTRUMENTS—35 watt 6L6 amplifier, 2 tube transceiver, movie camera takes movies and snaps 16mm. All in good working order.** C. H. Duncan, 231 Peachtree St., Rock Hill, S. C.

**WANT CAMERA, BINOCULARS, NATIONAL SW3, trade Western Electric cradle phone with cradle. 5 tube 2 band superhet kit. Dynamic speakers, 110 volt 1/20 HP motor, Weston meters.** M. Simon, Box 441, Gary, Indiana.

**WILL SWAP MEISSNER PUNIBUTTON** remote control unit for latest (1937-1938) television books or short wave transmitting equipment, or what have you? S. Preston, 37 Avon Place, Staten Island, New York.

**MOTIOGRAPH 35 MM CINE PROJECTOR.** 500 watt lamp, f:2 lens. Provisions for motor. Excellent mechanical condition. Want Leica camera or what have you? Write anyway. P. O'Donnell, 83 Sagamore Ave., Atlantic, Mass. U. S. A.

**SWAP THREE 001 VARIABLE CONDENSERS** out of Rad. 23, three 0005 var. condensers out of Rad. 20, for what have you in radio line? Newell Kelly, 208 Congress St., East Mead, Keesport, Pa.

**LOOK: FOREIGN SW LISTENERS.** Wish to correspond with you. All letters answered. Also want to join foreign radio clubs. Raymond Kastl, 465 Douglas St., San Francisco, California, U. S. A.

**HAVE 8 TUBE CUSTOM-BUILT** broadcast receiver—portable. In carrying case. Has built in speaker. Weston meter 0-5 volts. Thordarson audio transformers. Want Sky Buddy or similar receiver. Ann Collins, 6555 Kansas Ave., Los Angeles, Calif.

**WANTED: ANY KIND MOTION** picture equipment 8 mm or 16 mm films, cameras, projectors, solicers, rewinds, etc. Have radios, amplifiers, low powered transmitters, etc., to trade or will buy. Johnny Newsome, Box 725, Wake Forest, North Carolina.

**ONE E. S. C. O. GENERATOR** D.C. 500 volts at 2 amps. 12V. at 5.25 amps. with rheostat. Trade for test equipment or what am I offered? Lew Mink, 1450 Market St., San Diego, Cal.

**WANTED: LAFAYETTE 5 METER** receiver. Must have power supply. Would like speaker also, but is optional. Will pay cash or trade. Melvin Roppelt, 130 S. Houldin St., Baltimore, Maryland.

**HAVE 1928 MECHANICAL** Brunswick console phonograph, cost \$125.00 and 36 records. Like new. Wanted—SV receiver, code course. SWL equipment or what? Robert Parker, Box 41, Orden, Utah.

**WILL TRADE FOR REC. OR RADIO** parts. Camera, Voightlander 116, f4.5, 1 to 250th sec. With leather case. In excellent condition. K. Scanlan, 2003 LaBranch, Houston, Texas.

**HUNDREDS OF RADIO CHASSIS**, most of the popular makes up to 1933, less speakers and tubes. Will exchange for what have you? E. Cohen, 96 Radio Shop, 624 E. 6th St., New York City.

**S. W. RECEIVER 4 OR 5 TUBES** or test equipment wanted. Have drafting kit complete with "T" square triangles and curves and some cash. Paul Martin, 703 Madison St., Brooklyn, N. Y.

**SWL'S OF THE U. S. A. AND** other countries: Let's swap SWL cards. All cards answered. Norman Braun, 13306 Harvard Avenue, Cleveland, Ohio.

**WANT—SERVICING INSTRUMENTS,** typewriter and Riders manuals. Will buy or trade for: tubes, Philco Natl. Mag., type 1 P. 2. 80 v's. port. amplifier, 2-band A.C. radio, Isolator coils. Warren Freshli, New Richmond, Wisc.

**I QSL 100%—SEND ME UR SWL** card, I'll reply with 5 100% foreign QSL QTII's. Oversea SWL's: will carry correspondence with u; trade stamps; Harry Honda, 429 North Fremont Ave., Los Angeles, California, U. S. A.

**WANTED—LATE COMPLETE** Spryberry general radio course or any other radio courses or books. Send details. Trade for meters, generators, parts, etc., or what do you want? S. J. Niewicz, 79 Church St., Broad Brook, Conn.

**WILL SWAP GUITAR IN GOOD** condition for a 25-50 watt cw transmitter or pay cash. Must be in good condition and cheap. Send photo and so will I. Lucien Glutaro, Sturgeon Falls, Ont., Canada.

**HAVE AN 8 TO 10 WATT TRIAX,** complete with xtal, mike and tubes. Want movie camera, Proj. DX receiver, etc. What am I offered? Write A. Razzanda, Fayette City, Pa.

**HAVE HALLICRAWTER 1937 SKY** Chief model receiver. Will swap for test equipment. Receiver in good condition, used very little. Wm. D. Coggins, Conley, Ga.

**SWL'S IN ALL PARTS OF THE** world. I will exchange your cards for mine I QSL 100%. QRA Jack Johnston, 60 Court St., Medford, Mass., U. S. A.

**WILL SWAP A SHURE BROS.** mike desk type, also a 5 tube A.C. radio like new for a short wave receiver or what have you? Walter A. Richards, R. 3, Box 18, New Lisbon, Wis.

**WANT: HAYNES HSR COMPL.** w. 3-55M coils, tubes, spkr. good cond. State your price! Will swap parts for B. Elim. For inform. write to: J. Mueller, 1883 So. Blvd., Bronx, N. Y.

**WILL TRADE OLD TYPE AMERICAN** adding machine that doesn't print numbers on paper for a still usable used crystal of any frequency with holder. Paul Bahr, 1205 W. 10th St., Marion, Ind.

**HAVE: TEN METER PHONE** transmitter with 5 tubes complete, 2 tube 800, transceiver using 19 etc. Want: Test instruments, typewriter, dynamotor, head phones, tubes, Kodak or what have you? Barnett Mitchell, W4721, Route 4, Selma, Alabama.

**TRADE NOVELVIEWER SET** with 4 roll films, cost \$1.00. Want these books: "101 Short Wave Hook-ups," "How to Get Best Short Wave Reception," "10 Most Popular Short Wave Receivers," "Alexander Podstepny, 217 Pine St., Phila., Pa.

**SWAP CARTER GENEMOTOR 6V.** 4 1/2 A input 250V. 50 ma. output with filter, for test kit or meters also auto vibrator transformer and 1-4 gang condenser, coils and shields. Fuller, 709 Ferndale, Lansing, Michigan.

**SWAP ONE 125 ML. "PYREX"** Florence flask for radio parts. Cannot answer all letters. R. Sexton, 1329 E. 4th St., Charlotte, N. C.

**WOULD LIKE TO SWAP P.A.** equipment or parts, amplifiers for what have you? Send for list. Clara & Frank, Roxholder, P. O. Box 292, Centerville, Calif.

**HAVE NATIONAL SW-3 COMPLETE,** also portable 25 watt cw transmitter with motor generator. Want a good candid camera or PA system or what have you? A. C. Hecht, Jr., W3FWI, Box 92, Aspermont, Texas.

**WANTED—PEN-PALS INTERESTED** in radio or what, send your QSL or SWL card answer 100%. Write in French or English. QRA Maurice Dubreuil, Pine Grove Restaurant, Lavaltrie, Que., Canada.

**SWAP P. BOSCH AMPLIFIER** with two Bosch speakers in cabinet; new Shure mike and three section mike stand. Two radios. Also radio parts. What have you? Richard Kelley, 1034 Elm St., Franklin, Penna.

**WILL TRADE AN UP-TO-DATE** Lincoln Engineering radio course for a key, milliammeters, ham manuals, radio magazines, or a mandolin. What have you to trade? Leo Gruetzmacher, Thayer, Kansas.

**HAVE VAR. AND FIXED CONDENS.** crystals, dry rectifier type A-10, 8-1.0 amps. 2x3 tube resistors, toggle switch, and good fountain pen. Want "B" eliminator. Write Bill Sule, Box 98, Smithville, Ont., Canada.

**I HAVE ONE AIRLINE RADIO** 9 tubes, 2 speakers, 1932 model, not in working order. One table model cabinet. Will trade, Loren Hart, Vinton, Iowa.

**WANTED: MOTION PICTURE** equipment. Can make any kind of 8 mm. titles to trade for what have you? John C. Newsome, Box 725, Wake Forest, North Carolina.

**YOUR SWL CARD WILL BE AP-** preciated for my collection. Joseph Neuman, 2224 Woodstock Avenue, Swissvale, Pa.

**TRADE RME69 AND DB20 PRE-** selector same as new, latest model, for a Contax or Leica camera. N. B. Thornton, Somerville, Ohio.

**SWAP CHEMICALS AND EQUIP-** ment for any radio parts of value. Also notice SWL's. I will swap cards with anyone in U. S. and foreign countries. QRA Jack Spencer, 513 W. La. Ave., Ruston, La., U. S. A.

**SWAP: GROSS 3 TUBE SHOTT** wave battery receiver metal cabinet with \$20.00 E current supply lots valuable parts for 1/2 in electric drill or what have you? Jensen, 211 East 200 St., Bronx, N. Y.

**SWAP 1/2 METER TRANSMITTER** with Acorn tube, mike, ready to use with antenna; for record changer 110 V.A.C., candid camera, 5 meter trans, or. All letters answered. Albert Winnest, 237 47 Dayenport Ave., Bellefonte, Pa., N. Y.

**SWAP: A SINGLE BUTTON CAR-** bon microphone for a signal type E-63 telegraph key. Write for descriptions of the microphone. Leland E. Patience, Box 165, Leicester, Mass.

**WILL SWAP SWL CARDS AND** photo with anyone. Send yours and I'll send mine. QRA: Malcolm E. Purlenden, Jersey Ridge Road, Mayville, Kentucky.

**HAVE RADIO PARTS, MAGA-** zines Open Road, SW Craft, S W & T, Radio-Craft, Modern Mechanics, and stamps. Want receiver (3 or more tubes) or F. H. Frantz, 30 N. 4th St., Coplay, Pa.

**WANT .22 RIFLE, ALSO BLANK** guns. Will swap chemicals for pocket watch. M. Konon, 48 Edwards St., Patchogue, N. Y.

**TRADE STRATOSPHERE 10 RE-** ceiver, 6 months old complete with coils and hand mike. P. Silver, Woodbridge, New Jersey.

**WANTED—GOOD, USED 6L6** tube, 40 meter x'tal. Have movie projector, electric train 0 ga. 5" dynamic speaker new, several new tubes. Harry Wood, Route 1, Waverly, Washington.

**WILL TRADE GOOD 0-5 VOLTS** D.C. meter with zero adjustment for single or double button mike or what have you? Donald St. Germain, 6217 25 Ave., Kenosha, Wisconsin.

**WANTED: CODE MACHINE** with taper. Swap Packard Lectro Shaver, rectified dynamic speaker, or latest lowest cash price. Tom Killeen, 567 Walnut St., Elizabeth, N. J.

**WILL SWAP A SMALL SHORT** wave receiver covering 16 to 217 meters. With all tubes and coils. Want to trade for used Master Teleplex in good condition. D. W. Hawkins, 113 Lang St., Marlin, Tex.

**SWAP TENOR BANJO, PORT-** able phonograph, small PA system, Memo camera takes 50 pictures for 50c, double button mike, for portable 5 meter transceiver, typewriter with small type (standard). Alfred O. Kings, 87 87th Ave., Woodhaven, L. I., N. Y.

**TRADE: KODAK CAMERA, NO 3** Model "C." Want radio parts or license manual and other literature. All letters answered. B. C. Murray, Box 116, Ilion, New York.

**WANTED—BACK COPIES RADIO** magazines, a correspondence course, or A.C. battery charger. I have large speaker, earphones, good parts, small radios, power pack and analyzer parts. Clyde Hyde, R. R. No. 3, Brazil, Ind.

**WANTED: TRANSCEIVER USING** 2-19 and 1-30 tubes. Also carbon mike or handset. Have back issues American Boy, Open Road for Roys mag. stamps, radio parts. Leonard Makela, 1129 16th Ave. E. Hibbing, Minnesota.

**WILL TRADE NATIONAL SW3,** coils 13-70 meters. Power pack and amplifier, tubes and 35 diff. S W & T for Sky Buddy or similar "ham" superhet. E. Zallavetz, W2LKE, 894 Rogers, Pl. Bronx, N. Y.

**HAVE "UNIVEX" 8 MM MOVIE** camera, projector, films. Would like Sky Chief, Doerle D-38, Ellen RX-18-A8, or other good Ham receiver. Write Tom Cullen, 22 Simpson Ave., Wallingford, Conn.

**HAVE ONE PAIR OF DICTO-** graph. Type AD3 earphones (value \$8.00), one Boy Scout signaling set, will trade for Elgin Air Roamer III or 7? Write Thomas Combs, 1201 Woodland Ave., Bluefield, W. Va.

**COLLECTORS OF STAMPS AND** snips. To swap Malayan and foreign stamps, Oriental postcards and snips for those of us. Replies assured. Would appreciate ur SWL card. Joe Hye, P. O. Box 126, Iphof, FMS.

**WANTED: SKY BUDDY, SUPER** (Tipper, etc. Will trade 40 power telescope cost \$33.00 in fine condition. Paul E. Trued, Tribune, Kansas.



(Continued from page 286)

**WILL TRADE 5 TUBE HALLICRAFTERS** SW receiver using type 6D6, 6D6, 6C6, 42, 80 tubes. For 750 volt 200 mill xmitting power supply, milliammeters, or other transmitting equipment. Oiv. Saukkoia, 440 Elm Street, Fitchburg, Mass.

**I HAVE A BIKE, VARIABLE condensers, micas, tubes—receiving, microphone, audios, etc.** I will answer all letters, foreign or U. S. A., if stamps are provided for postage. Albert Sparks Wittlinger, 51-3 Salem St., Newark, N. J.

**SWAP A GILBERT 150 POWERED** microscope, a Gilbert optical kit, Lionel Electric train, stamp album with 250 stamps for Sky Buddy or similar receiver. Arthur Andrews, 315 E. 7th St., Anaconda, Mont.

**WUD LIKE TO SWAP CRDS** with fellowes YL's in New Zealand or Australia. WI ans all crds. QRA Tony Moravec, Jr., 1610 S. Allport St., Chicago, Ill., U. S. A.

**WANTED TO SWAP FOR BELL & Howell 8 mm movie equipment.** Have 1938 Philco 3XX \$154 receiver as well as ham gear etc. All letters answered. Fred P. Strother, W4FBK, Fitzpatrick, Alabama.

**HAVE FOR SWAP A COMMUNICATIONS** superhet, tubes 16-545 meters; all-wave superhet kit; short wave equipment; test equipment; radio books and magazines. Wanted: Portable type writer, John J. Vilkas, 1515 No. 49th Court, Chicago, Illinois.

**SWAP—AN AMPERITE MICROPHONE** model SR0-80 in good condition for an A.C. short wave receiver 5 to 550 meters or 16 mm movie camera. Harry Goldman, 488 East 139th St., Bronx, New York City, N. Y.

**WANTED RECORDING EQUIPMENT.** Have transmitters to swap as well as many parts. C. Kowalski, 1239 Kinmoor Ave., Fort Wayne, Ind.

**WANTED—GUITAR IN GOOD** condition. Have—RCA Spiderweb ant., W.E. 211, photographic eqpt., and 150 lbs. of popular mags. Write: David Bulkley, 85 Griffen Ave., New Rochelle, N. Y.

**WILL SWAP: CROMLEY, 127 TEN** tube set in A1 condition, and a large no. of radio parts for a Kelsey 5X8 printing press. Fred S. Brothers, P. O. Box 10, Marietta, Ohio.

**WANTED: 2 456 KC. I.F. TRANSFORMERS.** Have several speakers and power trans. Write for particulars. All mail answered. A. C. Alatory, 8 Sycuan Ave., Metuchen, N. J.

**TRADE ALL KINDS OF PARTS** like speaker, tuning dials, etc. Write to me for your parts. Some parts were never used. OM. Harry G. Post, 402 Ridge Avenue, Allentown, Pa.

**ENOUGH EQUIPMENT FOR 50** watt complete rig for some machine shop tools. Will give better end of bargain. H. Knapp, 4818 S. Elizabeth, Chicago, Ill.

**WANTED—USED CANDLE R** Junior code course complete, must not be sold, will buy best offer. Also wish to swap SWL cards. QRA—N. W. Hastings, P. O. Box 323, Middletown, N. Y.

**SWAP: TEN METER MOBILE** transmitter-receiver; Harr Transceiver, tubes; Gross CB25, complete; five meter AC or mobile transmitter, receiver; Mallory 200 volt packs; 8 volt eight inch speakers (dynamic). AV-JOM, 40 Wayland Street, Roxbury, Mass.

**I HAVE 16 COPIES OF NATIONAL** Geographic Magazine to swap for what have you? Write for list. Enclose postage for answer. Geo. W. Dadd-Pearsons, 302 S. Granite St., Prescott, Arizona.

**WILL SWAP 4.75x19 TUBE TUBE** and wire wheel, RCA motor and turntable, Weston model 506 0-100 D.C. milliammeter. What have you to offer? Write Jack Israel, 319 Peshine Ave., Newark, N. J.

**HAVE 5 TUBE NATIONAL RECEIVER** short wave, coils, 12" magnetic speaker, lightweight phones used by Airline. Aviation pictures. Swap for candle or motion picture equipment. Letters answered 100%. J. Admanson, TWA, 70 East 42nd St., N. Y. C.

**WANTED: 2 TUBE KADETTE** radio, Radiola 86 phono-radio with home recording, 8mm camera F.1.9 lens. Have nearly complete files 1932 radio mags. Also how to make. State wants. Will exchange. Larry Otis, 615 1/2 Front St., Norwalk, Calif.

**5 TUBE A.C. BROADCAST SET** no cabinet. Stamps for collectors, milliammeter, 3 tube Raco, 1 tube Pre-more, sw coils. Want musical instrument or radio service or receiving equipment. Albert Hartman, 5713 5th Avenue, Brooklyn, N. Y.

**SWL'S AND HAMS IN CANADA** and foreign countries, please send me your card. I will QSL 100%. I will also swap fotos. QRA—Earle L. Hoare, 83 Preston St., Halifax, N.S., Canada.

**WILL TRADE TEN TUBE A.C.** superhet, with tubes and speaker, A.V.C., tuning meter, and P.P. pentode output for complete phone transmitter, good multi-meter or set analyzer. R. L. Davis, Williamstown, Penna.

**TRADE—22 TARGET RIFLE,** telescope sight, micrometer mounts, excellent condition; accuracy test—five shots in three eighths inch at 50 yards for P17X complete or similar receiver. H. W. Trimble, DOD, Pedricktown, N. J.

**WANTED, ONE TWO GANG 140** mmfd. variable condenser, one 35 mmfd. variable. I also want the following tubes, one 6K7, 6J7, 6C5 and 6P6. Exchange all kinds of radio parts. Douglas Breedlove, Brazos, Oklahoma.

**RCA RADIOLA TWO TUBES** (30's), Model 3A. Six tube American Radio Model 86 Cruiser short wave equipment. Ham supplies. Exchange for 2 or 3 tube xtal transmitter, or? Walter O. Shivers, 472 3rd Ave., Macon, Ga.

**WANTED—LATHE—SWAP TEST** equipment, manuals, quartz lamp, cameras, s.w. receiver, gold watch, diamonds, rare coins, and medals. Rochelle Salt Crystals, cash and other goods. Denmark, 81 W. 172 St., N.Y.C.

**SHORT WAVE LISTENERS IN** all countries. Would like to exchange SWL cards with anybody. QRA. Fred A. Walt, 5 Fennington Street, Hindley, Nr. Wigan, Lancashire, Eng. and

**WILL TRADE ONE SHURE CRYSTAL** mike with cord and stand for well known camera, enlarger, or other photographic equipment. H. B. Ellis, 120 So. Cherry St., Richmond, Va.

**WILL SWAP NEW T55 NEVER** used and 2 4.4. heavy duty Aerovox oil filters, unused, for A.C. broadcast or s.w. rcvr. Inquiries invited. A. Demblec, 811 Jefferson, Cleveland, O.

**WILL TRADE BRAND NEW RADIO** Technical Institute's complete authorized Radio Servicing course, perfect condition, for anything radio. J. H. Hood, 37 Club Drive, Greenville, South Carolina.

**WANTED A USED B.F. A'DHO** oscillator and a vacuum tube volt meter, Triplet preferred but not necessary. Give make, model and cash price and condition when answering. R. J. Gardner, 2649 L St., San Diego, Calif.

**SWAP \$35 QUALIPENSATOR, 2** tube A.C. short wave set, speakers and microphones. Would like to have transmitter, receiver or good short wave set. All letters answered. Steve Novota, Jr., 406 S. Plum St., Moewana, Ill.

**SWL'S, THE BOYS OF "CAMP** Spotswood Radio Club" would like to swap cards with boys in U.S. and foreign countries. We QSL 100%. Pres. Chuck Cox, CXC (company 1387, Camp N.P.-3, Elkton, Va.

**WILL EXCHANGE 10X15 JONES-** Gordon printing press, 18 fonts type and misc. printing equipment for radio equipment or microscope. What is offered? Richards, 137 South Terrace Ave., 3H, Vernon, N. Y.

**WANTED TO BUY A GOOD** used Hallcrafters Sky Buddy and Sky-Chief. Please send complete details. Jose A. Garcia, Trinidad alta 23, Santiago de Cuba, Cuba.

**WILL SWAP POSTAL CARDS,** documentary and American from 1879 up; for stamps or small short wave receiver. Roy Harding, Minneapolis, Kansas.

**WILL SWAP SET OF AMERICAN** Encyclopedic Britannica for Sgt. Gen. Streamliner '39, new Sky Buddy, new Ace Do-All (Ultra model), Ellen RX-20 or what have you? William Beebe, 27 North Monroe, Columbus, Ohio.

**HAVE EIMAC 50-T AND RCA** 872-As. Remington No. 5 typewriter, 75 watt phone amitter, Winchester Springfield 30.06 Navy night-vision glasses. What have you? Baro. 35 Whitaker Ave., Rumford, R. I.

**5 METER TRANSMITTER, USES** 30-33 tubes. Will swap for meters, transmitting tubes or what have you? Built by WYGHW and WYFZB. Write Martin C. Derksema, WYFZB, 2297 East McGraw Street, Seattle, Wash.

**TRADE ONE RACO R9 SIGNAL** booster and preselector for small portable SW receiver or like. Helmut Gliese, 225 Delcator, Port Washington, Wis.

- Mc. Call
- 6.120 W2XE NEW YORK CITY, 49.02 m., Addr. Col. B'cast. System, 485 Madison Ave. 10.30-11.30 pm.
- 6.117 KEUZ MEXICO CITY, MEX., 49.03 m., Addr. 5 de Mayo 21. Relays XEFO 1-3 am.
- 6.115 OLR2C PRAGUE, CZECHOSLOVAKIA, 49.05 m. (See 11.42 r.c.)
- 6.110 KEPW MEXICO CITY, MEX., 49.1 m., Addr. La Voz de Aguila Azteca desde Mex., Apartado B403. Relays XEJW 11 pm.-1 am.
- 6.110 VUC CALCUTTA, INDIA, 49.1 m. Daily 2.06-4.36 am., 6.36 am.-12.06 pm.; Sat. 10.06 pm.-2.06 am., Sun. 7.36 am.-12.36 pm.
- 6.110 VPB COLOMBO, CEYLON, 49.1 m. Daily 7-9.30 am; Sun. 6.30-9.30 am.
- 6.108 HJABB MANIZALES, COL., 49.14 m., Addr. P. O. Box 175. Mon.-Fri. 12.15-1 pm.; Tue. and Fri. 7.30-10 pm.; Sun. 2.30-5 pm.
- 6.100 YUA BELGRADE, JUGOSLAVIA, 49.18 m. 12.45-2.30, 4-8 am., 1-6 pm.
- 6.100 W3XAL BOUND BROOK, N. J., 49.18 m., Addr. Natl. Broad. Co. 8.25 pm.-12 m.
- 6.100 W9XF CHICAGO, ILL., 49.18 m., Addr. N.B.C. 4-6.50 pm., 1.05-2 am. Sun. 1-5.50 pm.
- 6.100 — NOUMEA, NEW CALEDONIA, 49.18 m. Radio Noumea, Addr. Charles Gaveau, 44 Rue de l'Alma. 2-3.30 am., exc. Sun. and Mon.
- 6.097 ZRK KLIPHEUVEL, S. AFRICA, 49.2 m., Addr. S. African Broad. Co., Johannesburg. Daily 12 n.-4 pm., Sun. 12 n.-3.20 pm.
- 6.097 ZRJ JOHANNESBURG, S. AFRICA, 49.2 m. Addr. S. African Broad. Co. Daily exc. Sat. 11.45 pm.-12.50 am.; Daily exc. Sun. 3.15-7.30, 9-11.30 am. (Sat. 8.30-11.30 am.) Sun. 3.30-4.30 or 4-5 am., 5.30-7, 9-11.30 am.
- 6.095 JZH TOKYO, JAPAN, 49.22 m., Addr. (See 11.800 mc., JZ.) Irregular.
- 6.090 CRCX TORONTO, CAN., 49.26 m., Addr. Can. Broadcasting Corp. Daily 7.45 am.-5 pm., Sun. 10.30 am.-12 n.
- 6.090 ZBW2 HONGKONG, CHINA, 49.26 m., Addr. P. O. Box 200. Irregular.
- 6.085 HJSABD CALI, COLOMBIA, 49.3 m., Addr. La Voz de Valle. 12 n.-1.30 pm., 5.10-9.40 pm.
- 6.083 VQ7LO NAIROBI, KENYA, AFRICA, 49.31 m., Addr. Cable and Wireless, Ltd. Mon., Fri. 5.30-6 am., 11.15 am.-2.15 pm., also Tues. and Thurs. 8.15-9.15 am.; Sat. 11.15 am.-3.15 pm.; Sun. 10.45 am.-1.45 pm.
- 6.081 YVIRD MARACAIBO, VEN., 49.32 m. 6-11 pm.
- 6.080 W9XAA CHICAGO, ILL., 49.34 m., Addr. Chicago Fed. of Labor. Relays WCFL irregular.
- 6.079 DJM BERLIN, GERMANY, 49.34 m., Addr., Broadcasting House. Irregular.
- 6.077 OAX4Z LIMA, PERU, 49.35 m. Radio Nacional 7-11 pm.
- 6.075 VP3MR GEORGETOWN, BRI. GUIANA, 49.35 m. Sun. 7.45-10.15 am.; Daily 4.45-8.45 pm.
- 6.070 HJ3ABJ BOGOTA, COL., 49.42 m., La Voz de Bogota.
- 6.070 CFRX TORONTO, CAN., 49.42 m. Relays CFRB 7.30 am.-12 m., Sun. 10 am.-12 m.
- 6.070 VE9CS VANCOUVER, B. C., CAN., 49.42 m. Sun. 1.45-9 pm., 10.30 pm.-1 am.; Tues. 6-7.30 pm., 11.30 pm.-1.30 am. Daily 6-7.30 pm.
- 6.069 — TANANARIVE, MADAGASCAR, 49.42 m., Addr. (See 9.53 mc.) 12.30-12.45, 3.30-4.30, 10-11 am., Sun. 2.30-4.30 am.
- 6.065 S80 MOTALA, SWEDEN, 49.46 m. Relays Stockholm 1.30-5 pm.
- 6.060 — TANANARIVE, MADAGASCAR, 49.5 m., 12.30-12.45, 3.30-4.30, 10-11 am.
- 6.060 W8XAL CINCINNATI, OHIO, 49.5 m., Addr. Crosley Radio Corp. Relays WLW Tues., Fri., Sun. 5.45 am.-12 n., 11 pm.-2 am., Wed. 5.45 am.-12 n., 9 pm.-2 am., Mon., Thurs., Sat. 5.45 am.-2 am.

**Diversity Receiver for Hams**

(Continued from page 290)

Needless to say, with these advantages, this receiver provides a quality of reception that is unequalled by any single receiver.

Another advantage of this new set, aside from its diversity action, is in the Infinite Rejection Circuit embodied in it.

It is rather generally understood that selectivity can only be increased to a certain practical degree beyond which phone reception becomes unintelligible. This practical limit of selectivity is not great enough to prevent adjacent channel interference.

However, with the Infinite Rejection Circuit, an interfering signal may be completely eliminated. It is so designed that, with a single control, the "rejection slots" may be moved in unison from 20 kc. off resonance to within 3 kc. of the signal being received, and simply by tuning the rejector to the offending signal, it can be entirely eliminated.

To provide the maximum flexibility and versatility in operation, the power supply and audio amplifier are supplied as separate units.

The component parts of the system are constructed of heavy gauge, flame-welded

metal, sturdy channel construction, finished in black crystal. The channels themselves are finished in chromium, contrasting with the black crystal. The instrument panels are "aluminited," a satin aluminum finish.

**Features**

Diversity reception throughout its tuning range.

6 bands covering from 545 kc. to 62 mc. and there are 23 tubes in the complete system.

Separate "Diversity Action" meters. Average sensitivity of better than 1 microvolt.

2 stages of R.F. amplification in each receiving section.

500 and/or 1,000 cycle Hetrotrone oscillator for c.w. reception.

Audio amplifier output of 10 watts. (Tuner only 50 milliwatts.)

Carrier average output meter. Current equalizing meter.

Infinite adjacent channel rejector. Separate electro-mechanical band-spread control.

This article has been prepared from data supplied by courtesy of the Hallicrafters, Inc.



Mc. Call

6.060 W3XAU PHILADELPHIA, PA., 49.5 m. Relays WCAU Tues., Fri., Sun. 12 n.-11 pm.; Wed. 12 n.-9 pm.

6.057 ZHJ PENANG, FED. MALAY STATES, 49.51 m. 6.40-8.40 am., except Sun., also Sat. 11 pm.-1 am.

6.054 HJ6ABA PEREIRA, COL., 49.52 m. 9.30 am.-12 n., 6.30-10 pm.

6.050 HP5F COLON, PAN., 49.59 m., Addr. Carlton Hotel. Irregular.

6.045 XETW TAMPICO, MEXICO, 49.6 m. Irregular 7-11 pm.

6.042 HJIABG BARRANQUILLA, COL., 49.65 m., Addr. Emisora Atlantico. 11 am.-11 pm.; Sun. 11 am.-8 pm.

6.040 W4XB MIAMI BEACH, FLA., 49.65 m. 1-3 pm., 9 pm.-12 m. Relays WIOD.

6.040 WIXAL BOSTON, MASS., 49.65 m., Addr. University Club. Irregular.

6.040 YDA TANDJONGPRIK, JAVA, 49.65 m., Addr. N.I.R.O.M., Batavia, 10.30 pm.-2 am.; Sat. 7.30 pm.-2 am.

6.033 HP5B PANAMA CITY, PAN., 49.75 m., Addr. P. O. Box 910. 12 n.-1 pm., 7-10.30 pm.

6.030 VE9CA CALGARY, ALTA, CAN., 49.75 m. Thur. 9 am.-1 am.; Sun. 12 n.-12 m.

6.030 OLR2B PRAGUE, CZECHOSLOVAKIA, 49.75 m. (See 11.875 mc.) Thurs. 4.45-5.10 pm.; Wed. 5.15-5.40 pm.

6.023 XEUW VERA CRUZ, MEX., 49.82 m., Addr. Av. Independencia 98. 8 pm.-12.30 am.

6.020 DJC BERLIN, GERMANY, 49.83 m., Addr. (See 6.079 mc.) 10.40 am.-4.30 pm.

6.017 H13U SANTIAGO DE LOS CABALLEROS D. R., 49.85 m. 7.30-9 am., 12 n.-2 pm., 5-7 pm., 8-9.30 pm.; Sun. 12.30-2, 5-6 pm.

6.015 PRA8 PERNAMBUCO, BRAZIL, 49.84 m., Radio Club of Pernambuco, 6-9 pm.

6.012 ZHP SINGAPORE, MALAYA, 49.89 m. 5.40-9.40 am., irregular.

6.010 OLR2A PRAGUE, CZECHOSLOVAKIA, 49.92 m., Addr. (See OLR 11.84 mc.) Thurs. 4.45-5.10 pm.; Wed. 5.15-5.40 pm.

6.010 COCO HAVANA, CUBA, 49.92 m., Addr. P. O. Box 98. Daily 7.55 am.-12 m., Sun. until 11 pm.

6.010 VK9MI S. S. KANIMBLA, 49.92 m. (Travels between Australia and New Zealand). Sun., Wed., Thurs. 6.55-7.30 am.

6.010 CJCX SYDNEY, NOVA SCOTIA, 49.92 m. Relays CJC8 7 am.-1 pm., 4-8 pm.

6.007 ZRH ROBERTS HEIGHTS, S. AFRICA, 49.94 m., Addr. (See ZRK, 9.606 mc.) Daily exc. Sun. 10 am.-3.30 pm.; Sun. 9 am.-12 n., 12.15-3.15 pm. Daily exc. Sat. 11.45 pm.-12.50 am.

6.007 ZRJ JOHANNESBURG, S. AFRICA, 49.94 m., Addr. S. African Broadcast. Co., 3.30-4 pm. exc. Sun.

6.005 HP5K COLON, PAN., 49.96 m., Addr. Box 33, La Voz de la Victor. 7-9 am., 10.30 am.-1 pm., 5-11 pm.

6.005 CFCX MONTREAL, CAN., 49.96 m., Can. Marconi Co. Relays CFCF 6.45 am.-12 m.; Sun. 8 am.-10.15 pm.

6.005 VE9DN DRUMMONDVILLE, QUE., CAN., 49.96 m., Addr. Canadian Marconi Co.

6.004 RV59 MOSCOW, U.S.S.R., 49.97 m. Irregular.

6.002 CXA2 MONTEVIDEO, URUGUAY, 49.98 m., Addr. Rio Negro 1631. Relays LS2, Radio Prieto, Buenos Aires. 10.30 am.-10.30 pm.

6.000 ZEA SALISBURY, RHODESIA, S. AFRICA, 50 m. (See 6.147 mc., ZEB.) Also Sun. 3.30-5 am.

6.000 XEBT MEXICO CITY, MEX., 50 m., Addr. P. O. Box 79.44. 8 am.-1 am.

**End of Broadcast Band**

5.977 CS2WD LISBON, PORTUGAL, 50.15 m., Addr. Rua Capelo 5. 3.30-6 pm.

5.975 OAX4P HUANCAYO, PERU, 50.16 m. La Voz del Centro del Peru. 8 pm. on.

5.968 HVJ VATICAN CITY, 50.27 m. 2-2.15 pm. daily; Sun. 5-5.30 am.

5.940 TG2X GUATEMALA CITY, GUAT., 50.47 m. 4-6, 9-11 pm.; Sun. 2-5 am.

5.940 PJCI CURACAO, CURACAO, 50.47 m., Mon., Wed., Fri. 6.36-8.36 pm., Sun. 10.36 am.-12.36 pm.

**AMERICA'S MOST POPULAR RADIO BOOKS**

We herewith present a selected collection of recent important radio books. We have selected these volumes because they represent the foremost radio books of their kind in print today. We publish no catalog. Order direct from this page. Prompt shipments will be made to you. Remit by money order or certified check. Register all letters containing cash.

**RADIO ENGINEERING HANDBOOK**, 850 pages, latest..... **\$4.90**

**PRACTICAL TELEVISION**, 223 pages, 127 illus..... **\$3.69**

**ELEMENTS OF RADIO COMMUNICATION**, 286 pages, 241 illus..... **\$2.98**

**RADIO PHYSICS COURSE**, 992 pages, 510 illus..... **\$4.00**

**THE RADIO AMATEUR'S HANDBOOK**, 448 pages, 126 illus..... **\$1.97**

**MODERN RADIO ESSENTIALS**, over 200 pages, and over 100 illus..... **\$1.95**

**FOUNDATIONS OF RADIO**, 246 pages, 145 illus..... **\$2.47**

**PHOTODELTS AND THEIR APPLICATION**, 332 pages, 180 illus..... **\$2.88**

**ELECTRONICS**, 134 pages, 45 illus..... **\$1.95**

**SHORT WAVE RADIO HANDBOOK**, 128 pages, 150 illus..... **\$1.00**

**PRINCIPLES OF RADIO**, 478 pages, 306 illus..... **\$3.46**

**EXPERIMENTAL RADIO**, 168 illus., Prepaid..... **\$2.69**

**MODERN RADIO SERVICING**, 1300 pages, over 700 illus..... **\$4.00**

**FIELD SERVICE DATA AND ANSWER BOOK**, 436 pages..... **\$2.50**

Both Books..... **\$6.00**

**DRAKE'S CYCLOPEDIA OF RADIO AND ELECTRONICS**, 1050 pages, 1178 illus..... **\$4.88**

**FUNDAMENTALS OF RADIO**, 246 pages, illustrated, Prepaid..... **\$3.46**

**HOW TO PASS RADIO LICENSE EXAMINATIONS**, 1938 Edition, 201 pages, illustrated..... **\$2.00**

**RADIO CONSTRUCTION AND REPAIRING**, 444 pages, illustrated..... **\$2.50**

**THEORY OF VACUUM TUBE CIRCUITS**, 226 pages, 226 illus..... **\$3.00**

**PRINCIPLES OF RADIO COMMUNICATION**, 988 pages, profusely illus..... **\$7.35**

**RADIO ENGINEERING**, 813 pages, 475 illus..... **\$5.50**

**EXPERIMENTAL RADIO ENGINEERING**, 346 pages, 250 illus..... **\$3.46**

**RADIO OPERATING QUESTIONS AND ANSWERS**, 427 pages, 106 illus..... **\$2.50**

**OFFICIAL RADIO SERVICE HANDBOOK**, over 1,000 pages, over 1,000 illus., Prepaid..... **\$3.92**

**OFFICIAL SHORT-WAVE RADIO MANUAL**, Volume 5, over 3,000 illustrations, Vol. 1 (1934) Prepaid..... **\$2.00**

Vol. 2 (1935) Prepaid..... **\$2.50**

**OFFICIAL RADIO SERVICE MANUAL**, Volume 4, 2,000 illus., over 400 pages, Prepaid..... **\$3.43**

**OFFICIAL RADIO SERVICE MANUAL**, Volume 5, over 3,000 illus., over 1,000 pages, Prepaid..... **\$6.86**

**OFFICIAL RADIO SERVICE MANUAL**, Volume 6, over 1,200 pages, over 2,500 illus., Prepaid..... **\$6.86**

**15 HANDY—POCKET-SIZE RADIO BOOKS**

Here are 15 up-to-date books on radio and air conditioning. Modern in every sense. ALL BOOKS UNIFORM—they contain 64 pages, 50 to 120 illustrations. All books written by well-known authors. Order by Number.

2. MODERN VACUUM TUBES
  3. THE SUPERHETERODYNE BOOK
  5. HOW TO BECOME A SERVICE MAN
  6. BRINGING ELECTRIC SETS UP TO DATE
  8. RADIO QUESTIONS AND ANSWERS
  9. AUTOMOBILE RADIO AND SERVICING
  10. HOME RECORDING AND ALL ABOUT IT
  12. PUBLIC ADDRESS INSTALLATION AND SERVICE
  13. ABC OF AIR CONDITIONING
  14. POCKET RADIO GUIDE
  15. ABC OF REFRIGERATION
  16. PRACTICAL RADIO CIRCUITS
  17. SERVICING WITH SET ANALYZERS
  18. POINT-TO-POINT RESISTANCE ANALYSIS
  19. PRACTICAL RADIO KINKS AND SHORT CUTS
- PRICE PREPAID EACH BOOK..... **50c**

**HOW TO ORDER**

No C.O.D. orders. Our prices are net, as shown. Some of the books sent prepaid (in U.S. only). Those that are not thus listed are shipped collect, if sufficient postage is not sent. Add 7% of price for postage.

**RADIO PUBLICATIONS, 97 HUDSON ST., NEW YORK, N. Y.**

**METAL SLIDE RULES!**

4 inch diameter metal slide rule (with case). Equivalent scale length is about 12 inches. Performs all the regular slide rule computations. Roots, logs, sines, etc. Endorsed by colleges. Accurate, handy. Price \$2.00. Special—large scale divisions, easy reading, equivalent scale length about 20 inches. Price, with case, \$5.00.

DATAPRINT CO., Lock Box 322a, Hamsey, N.J.

Mc. Call

5.935 YVIRL MARACAIBO, VEN., 50.52 m., Addr. Radio Poplar, Jose A. Higuera M. P. O. Box 247. Daily 11.43 am.-1.43 pm., 5.13-10.13 pm.; Sun. 9.13 am.-3.13 pm.

5.913 YV4RP VALENCIA, VEN., 50.71 m. Irreg.

5.900 ZNB MAFEKING, BRI. BECHUANALAND S. AFRICA, 50.84 m., Addr. The Govt. Engineer, P. O. Box 106. 6-7 am. 1-2.30 pm.

5.900 TILS SAN JOSE, COSTA RICA, 50.85 m. 6-10 pm.

5.898 YV3RA BARQUISIMETO, VEN., 50.86 m., Addr. La Voz de Lara, 12 n.-1 pm., 6-10 pm.

5.892 HH2S PORT-AU-PRINCE, HAITI, 50.89 m., Addr. P. O. Box A103. 7-9.45 pm.

5.890 JIC TAIHOKU FORMOSA, 50.9 m. Works Tokio 5-10 am. irregular.

5.885 HI9B SANTIAGO, D. R., 50.95 m. Irregular 6-11 pm.

5.875 HRN TEGUCIGALPA, HONDURAS, 51.06 m. 1.15-2.16, 8.30-10 pm.; Sun. 3.30-5.30, 8.30-9.30 pm.

5.855 H11J SAN PEDRO DE MACORIS, D. R., 51.25 m., Addr. Box 204. 12 n.-2 pm., 6.30-9 pm.

5.853 WOB LAWRENCEVILLE, N. J., 51.26 m., Addr. A.T.&T. Co. Works Bermuda nights.

5.845 YVIRB MARACAIBO, VEN., 51.3 m., Addr. Apartado 214. 8.45-9.45 am., 11.15 am.-12.15 pm., 4.45-9.45 pm.; Sun. 11.45 am.-12.45 pm.

5.830 TDD SHINKYO, MANCHUKUO, 51.46 m. Works Tokyo 5-10 am., irreg.

(Continued on following page)

**300 WAYS**

To Make Money 10¢

**CASH IN!**

MAIL ORDER PLANS TESTED MONEY MAKERS BUSINESS SECRETS SUCCESS SCHEMES

25 CENTS

Regular Price 25¢ Special at 10¢ for short while only.

In "CASH IN" you will find over 300 ways to make money—dozens of profitable tested mail order plans, confidential business secrets, dozens of practical tested formulas, sources of supplies, successful, and honest tested schemes—many actual experiences of men who have started on the proverbial shoestring—with less than \$10 capital.

**Buyers of This Book Tell Us—**

"The biggest dime's value I've yet to see. The book is worth at least one dollar." SAMSON BUDA, Brooklyn, N. Y.

"Your book is as good if not better than others selling at \$1.00." GEORGE BRUNET, Montreal, Canada.

"CASH IN is the best value I have yet to see in the mail order field." LAWRENCE FOX, Brooklyn, N. Y.

"CASH IN" contains 68 pages of tested ideas covering every type of full-or spare-time enterprise—it is really a "masterpiece" in business ventures—OVER 40,000 WORDS IN THE TEXT.

Sent POSTPAID anywhere in U.S. upon receipt of ten cents in stamps or coin.

Remember—your money back if not satisfied.

**NATIONAL PLANS INSTITUTE**  
246-T FIFTH AVENUE NEW YORK, N. Y.

# Westinghouse Power Generator

Manufactured for U. S. Signal Corps  
200 Watt. 110 V. AC

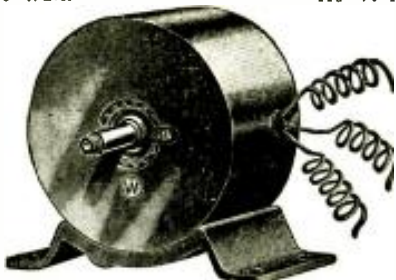

## A. C. ELECTRICAL POWER

from a Windmill, from available Waterpower from your Automobile, from your Motorcycle, from your Bicycle, Foot-pedals or Handcrank (for transportable Radio Transmitters, Strong Floodlights, Advertising Signs); do you want to operate AC Radio sets from 32 V. D.C. farm light systems; operate two generators in series to get 200 V. AC; obtain two phase and three phase AC, etc., etc.

**There Are Over 25 Applications**  
Some of which are:

A.C. Dynamo lighting from eight to ten 20 Watt 110 Volt lamps. Short Wave Transmitter supplying 110 Volts AC for operating "Ham" transmitter. Operating 110 V. AC 60 Cycle Radio Receiver in D.C. districts. Motor Generator. Public Address Systems. Electric Sirens on motor boats, yachts, etc. (lamp lighting). Short Wave artificial "ferret" apparatus. Television. Pelton Waterwheel for lighting or other purposes. Airplane: for lighting strong searchlights or electric signs. Laboratory work, etc., etc. 1/4 to 1/2 H.P. needed to run generator.

BLUE-PRINT 22 x 28 in. and Four-Page  
8 1/2 x 12 in. INSTRUCTION SHEETS  
FREE with Generator.

Generator, as described, including four replacement carbon brushes. Blue print and instructions.....

**\$790**

Send \$2.00 deposit, balance C.O.D.  
Shipping weight 18 lbs.

(Replacement carbon brushes bought separate \$1.50 per set of four. Set of instructions bought separate \$1.00.)  
MONEY-BACK GUARANTEE

**WELLWORTH TRADING COMPANY**  
660 West Washington Blvd. Dept. SW-939 Chicago, Ill.

**WE HAVE The RADIO YOU WANT**



How would you like to save up to 50% on Nationally advertised Radios, such as Stromberg Carlson, Philco, RCA, Zenith, G. E. etc. etc. for home, farm and auto, over 400 models to choose from. Also hundreds of electric appliance items for the home. Write today for the new 1938 giant catalog FREE.

MODELL'S Dept. 60 Cortlandt St., N.Y.C.

# FOR THE RADIO SERVICE MAN, DEALER AND OWNER

The man who enrolls for an I.C.S. Radio Course learns radio thoroughly, completely, practically. When he earns his diploma he will KNOW radio. We are not content merely to teach the principles of radio, we want to show our students how to apply that training in practical, every-day, radio service work. We want them to make good, to make money, to be successful radio experts.

**INTERNATIONAL CORRESPONDENCE SCHOOLS**

Box 2880-E Scranton, Penna.

Explain fully about your course in the subject marked X

RADIO  
 EXPERIMENTAL TELEVISION  
 SOUND TECHNICIANS  
 AVIATION SECTION OF RADIO OPERATING

Name \_\_\_\_\_ Age \_\_\_\_\_

Address \_\_\_\_\_

## World S-W Stations

(Continued from preceding page)

Mc.	Call	Location
5.825	TIGPH	SAN JOSE, COSTA RICA, 51.5 m., Addr. Alma Tica, Apartado 800. 11 am.-1 pm., 6-10 pm. Relays TIX 9-10 pm.
5.813	TIGPH2	SAN JOSE, COSTA RICA, 51.59 m., Addr. Senor Gonzalo Pinto, H.
5.800	YV5RC	CARACAS, VEN., 51.72 m., Addr. Radio Caracas. Sun. 8.30 am.- 10.30 pm. Daily 7-8 am., 10.30 am.-1.45 pm., 3.45-9.30 pm.
5.790	JVU	NAZAKI, JAPAN, 51.81 m. Works JIC and TDD irregular.
5.758	YNOP	MANAGUA, NICARAGUA, 52.11 m. 8-9.30 pm.
5.740	YV2RA	SAN CRISTOBAL, VENEZUELA, 52.23 m., Addr. La Voz de Tachira. 11.30 am.-12 n., 5.30-9 pm., Sun. till 10 pm.
5.740	TGS	GUATEMALA CITY, GUAT., 52.23 m. Irregular.
5.735	HCIPM	QUITO, ECUADOR, 52.28 m. Ir- regular 10 pm.-12 m.
5.145	OKIMPT	PRAGUE, CZECHOSLOVAKIA, 58.31 m., Addr. (See OLR, 11.84 mc.) Fri. 4.45-5.10 pm.; Sat. 5.15- 5.40 pm.
5.145	PMY	BANDOENG, JAVA, 58.31 m. 5.30- 11 am.
5.077	WCN	LAWRENCEVILLE, N. J., 59.03 m. Addr. A.T.&T. Co. Works England late at night irregularly.
5.025	ZFA	HAMILTON, BERMUDA, 59.65 m. Works N.Y.C. irregularly at night.
5.000	TFL	REYKJAVIK, ICELAND, 60 m. Works Europe night time irreg.
4.995	VUD2	DELHI, INDIA, 60.06 m., Addr. All India Radio. 7.30 am.-12.30 pm.
4.975	GBC	RUGBY, ENG., 60.3 m. Works ships irregularly.
4.905	VUB2	BOMBAY, INDIA, 61.16 m. Addr. All India Radio, 7 am.-12.30 pm.
4.900	HJ3ABH	BOGOTA, COL., 61.19 m., Addr. Apartado 565. 12 n.-2 pm., 6-11 pm.; Sun. 12 n.-2 pm., 4-11 pm.
4.880	HJ4ABP	MEDELLIN, COL., 61.44 m. 8-11 pm.
4.842	HJ3ABD	BOGOTA, COL., 61.95 m., Addr. La Nueva Granada, Box 509. 12 n.- 2 pm., 7-11 pm., Sun. 5-9 pm.
4.820	GDW	RUGBY, ENG., 62.24 m. Works N.Y.C. night time irregularly.
4.800	HJIABE	CARTAGENA, COL., 62.46 m., La Voz de los Laboratorios Fuentes. Addr. Box 31. Daily 8.30 am.-11 pm., Sun. 10 am.-9 pm.
4.780	HJIABB	BARRANQUILLA, COL., 62.72 m. La Voz de Barranquilla. Addr. P. O. Box 715. 11.30 am.-1 pm., 4.30-10 pm.
4.772	HJIABJ	SANTA MARTA, COL., 62.85 m. 11.30 am.-2 pm., 5.30-10.30 pm. except Wed.
4.752	WAQ	OCEAN GATE, N. J., 63.1 m., Addr. A.T.&T. Co. Works ships irregularly.
4.740	HJ6ABC	IBAGUE, COL., 63.25 m. 7 pm.-12 m.

## DX Receiving Aerials

(Continued from page 300)

This aerial is sharply directional from "X," as shown in the diagram. It is particularly suitable for reception from a given station or direction.

The length of the "V" portion of the aerial determines the wavelength at which greatest signal strength is obtained. Data for construction is given in the accompanying chart.

Where Length of Side Equals 3/4 Wavelength			
W.L. (Mct.)	Height (W-Y)	Base (X-Z)	Wire (X-W-Z)
17	39' 3 1/2"	28' 2 1/2"	83' 7"
20	43' 3 1/2"	32' 9 1/2"	98' 3 1/2"
25	59' 1"	41' 3 1/2"	123'
Where Length of Side Equals 1 1/4 Wavelengths			
17	54' 1"	83' 7 1/2"	139' 6"
20	65' 7 1/2"	98' 3 1/2"	164'
25	82'	124' 9 1/2"	205'

—Courtesy Australasian Radio World.

## Index to Advertisers

<b>A</b>	
Allied Radio Corporation.....	293
Astatic Microphone Laboratory, Inc.....	303
<b>B</b>	
Barter & Exchange Free Ads.....	316, 317, 318
Bliley Electric Co.....	303
Brush Development Co., The.....	301
<b>C</b>	
Candler System Co.....	298
Commercial Notices.....	316
Coyne Electrical School.....	259
<b>D</b>	
Dataprint Company.....	309, 319
Dodge's Institute.....	298
<b>F</b>	
For Sale Ads.....	316
<b>G</b>	
Gold Shield Products.....	307, 312
<b>H</b>	
Hammarlund Manufacturing Co., Inc.....	295
Henry Radio Shop.....	303
Hudson Specialties Company.....	302
<b>I</b>	
Instructograph Company.....	298
International Correspondence Schools.....	320
<b>K</b>	
Korrol Radio Products Co.....	305
Kusterman, Oscar B.....	295
<b>M</b>	
Miami Laboratories, Inc.....	301
Modell's.....	320
<b>N</b>	
National Company, Inc.....	Inside Back Cover
National Plans Institute.....	319
National Radio Institute.....	257
National Schools.....	306
New York YMCA Schools.....	306
<b>R</b>	
Radio Amateur Course.....	260
Radio & Electronic Dictionary.....	298
Radio & Technical Publ. Co.....	300
Radio Corporation of America.....	Back Cover
Radio-Craft.....	305
Radio Publications.....	306, 309, 319
Radio Training Assn. of America.....	300
RCA Institutes, Inc.....	300
Remington Rand, Inc.....	297
<b>S</b>	
Short Wave Coil Data Book.....	315
Short Wave League.....	310, 311
Solar Mfg. Corp.....	295
Sprague Products Co.....	305
Sprayberry Academy of Radio.....	299
<b>T</b>	
Technifax.....	315
Telechart.....	300
Telex Co.....	299
Triplet Electrical Instrument Co.....	301
Tri-State College.....	299
<b>U</b>	
United Radio Co.....	303
<b>W</b>	
Wellworth Trading Company.....	307, 320
Wholesale Radio Service Co., Inc.....	305

(While every precaution is taken to insure accuracy, we cannot guarantee against the possibility of an occasional change or omission in the preparation of this index.)



*The NC-100X  
in new dress*

# NC 100-XA



National's policy of constant improvement in its products is well illustrated by the recent redesign of the mechanical details of the NC-100X Receiver.

**THE NEW DIAL** has direct reading scales for each band, calibrated in megacycles. An additional vernier dial reads to one part in a thousand, for accuracy in logging.

**THE COIL-CHANGE MECHANISM** is ganged to the dial pointer, which moves radially to point directly to the proper scale. The movable coil system and the electrical circuit are unchanged, as experience has shown them to be high in efficiency and sound in design.

**THE SIGNAL-STRENGTH METER** is new and takes the place of the less convenient "magic eye" formerly used

**THE NEW CABINET** has been completely restyled. Its clean simple lines are free from gadgets and superfluous trim. The new NC-100XA is a straight high-performance job, stripped for action.

**THE PRICE** will be no higher, for the time being.

**NATIONAL COMPANY, INC., MALDEN, MASS.**



# RCA Research is the Basis of Radio in the Home!



Today's magnificent reception has been developed by years of patient work in RCA Laboratories

Most of us can recall the early crystal sets, when the marvel of hearing music by wireless first startled the world. Poor quality of reception was offset by the wonder of the achievement.

A year before these crude receivers came into public use RCA had already established a laboratory for developing radio reception for the home. From this humble beginning great things have come. Today, hundreds of trained RCA engineers devote their time to this work. Research in RCA laboratories has produced, or inspired, virtually all important advances in the quality of home receiving instruments.

### *An all-inclusive business*

Similarly, swift, direct radio communication with 43 foreign nations, and with ships at sea, is a result of RCA research. Other results include revolutionary improvements in the recording and reproduction of sound on records and motion picture films; indispensable new aids to police and aviation, to science and industry. And, thanks to years of unremitting study by RCA engineers, the new arts of television and facsimile now give promise of rendering important public services.

The Radio Corporation of America has invested millions of dollars in research to make radio—and the by-products of radio—more efficient and more economical, and to give to the United States, in every phase of radio development, undisputed world leadership.

Scene in RCA laboratory as engineer operates control board of device for recording tone quality of radio receiving instruments. This is but one of the many intricate pieces of equipment used in developing the fine quality of RCA Victor radios.



*Listen to the Magic Key of RCA, presented every Sunday, 2 to 3 p. m., E. D. S. T., over NBC Blue Network*



## Radio Corporation of America

RADIO CITY, N. Y.

RCA MANUFACTURING CO., INC.    RCA INSTITUTES, INC.    RCA COMMUNICATIONS, INC.  
RADIOMARINE CORPORATION OF AMERICA    NATIONAL BROADCASTING COMPANY